

# SERVICE MANUAL



Ver 1.1



ISSUE DATE: Feb. 15, 2019



- ▶ Please read the manual carefully and keep it in mind before using this machine.
- ▶ Put this manual within touch of your reference in anytime.

# PRECAUTIONS FOR USE

The following safety precautions are given throughout this manual. They must be strictly followed to protect those who install, use or maintain this product as well as to protect players, visitors and property.

## For safety reasons.

- The following suggestions should be adhered to:



Disregarding could result in serious injury.



Disregarding could result in injury or product damage.

- The following graphic suggestions describe the types of precautions to be followed.



Indicates a care should be taken.



Forbidden.



Indicates a matter which must be performed.

- **Precautions to be followed:**

**Certain procedures require a qualified in-shop maintenance person or industry specialist.**

**For such instructions, a qualified person must take care of the jobs.**

- Otherwise an electric shock, machine trouble or a serious accident may result.
- Replacing the machine parts, inspecting and maintaining the machines and troubleshooting must be assigned only to a qualified in-shop maintenance person or industry specialist. This booklet gives instructions that hazardous jobs in particular must be handled by an industry specialist. Qualified in-shop maintenance person and industry specialist are defined as follows.

### **Qualified in-shop maintenance person**

- A service staff shall have experience in operations of game machines. The staff shall be responsible for assembly, installation, inspection and maintenance of the machine.

### **Industry specialist**

- An industry specialist must be engaged in designing, manufacturing, inspecting and servicing amusement machines. He or she must have an education in electrical, electronic and mechanical engineering and routinely maintain and repair amusement machines.

# PRECAUTIONS FOR USE

## WARNING

**Be sure to consult an industry specialist when setting up, moving or transporting this product.**

- This product should not be set up, moved or transported by any one other than an industry specialist.
- When installing this product, set the 4 leg levelers evenly on the floor and make sure that the product is installed stably in a horizontal position. Unstable installation may result in injury or accident.
- When installing this product, do not apply undue force on movable parts. Otherwise, injury and accident may result, or the product may be damaged.

**The machine for indoor usage only does not install outside.**



**Do not set the game machine up near emergency exits.**



**Protect the game machine from:**

- Rain or moisture.
- Direct sunlight.
- Direct heat from air-conditioning and heating equipment, etc..
- Hazardous flammable substances.
- Otherwise an accident or malfunction may result.



**Do not place containers holding chemicals or water on or near the game machine.**



**Do not place objects near the ventilating holes.**



**Do not bend the power cord by force or place heavy objects on it.**



**Never plug or unplug the power cord with wet hands.**



**Never unplug the game machine by pulling the power cord.**



## CAUTION

**Be sure to use indoor wiring within the specified voltage requirements. For extension cord, use the specified rating or more.**

**Be sure to use the attached power cord.**

**Never plug more than one cord at a time into the electrical receptacle.**



**Do not lay the power cord where people walk through.**



**Be sure to ground this product.**



**Do not exert excessive force when moving the machine.**



**For proper ventilation, keep the game machine 100mm(4") away from the walls.**

**Do not alter the system related dipswitch settings.**

# PRECAUTIONS FOR USE

## WARNING

**If there is any abnormality such as smoke, bad smell or abnormal noise being emitted from the machine, immediately turn OFF the main power switch and unplug the power cord from the receptacle to stop operating it.** 

- Using the machine in abnormal conditions could result in fire or accidents.

### In case of abnormality

1. Turn OFF the main power switch.
2. Unplug the power cord from the receptacle.
3. Contact your nearest dealer.

**Do not leave the power cord plugged in improperly or covered with dust.** 

- Doing so could result the power cord periodically.

## CAUTION

**Do not use this product anywhere other than industrial areas.** 

- Using in a residential area or an area next to a residential area could affect signal reception of radios, television sets, telephones and etc..
- Do not give shock the surface of glass products.

- Please do not play this game if
  - When you do drinking;
  - When your physical condition is not normal;
  - When you are in pregnancy;
  - When you have on a pulse controller;
  - When you have recently experienced a cramp or fainting away while watching TV.
- Avoid excessive force/shock while playing/moving the game.
- While do games, pay attention to surrounding.

**Do not plug or unplug the power cord with wet hands.** 

**In handling the power cord, follow the instructions below.** 

- |   |  |
|---|--|
| • Do not damage the power cord.           | • Do not modify the power cord.            |
| • Do not bend the power cord excessively. | • Do not twist the power cord.             |
| • Do not heat the power cord.             | • Do not pull the power cord.              |
| • Do not bind the power cord.             | • Do not stand on the power cord.          |
| • Do not sandwich the power cord.         | • Do not drive a nail into the power cord. |

**If the power cord or power plug becomes damaged, stop using the machine immediately and ask your nearest dealer to replace the parts.**

**\* Electromagnetic wave may cause unexpected noise from speaker.**



# PRECAUTIONS FOR USE

## ⚠ WARNING

Be sure to turn OFF the main power switch and unplug the power cord from the receptacle before inspecting or cleaning the machine.



When replacing parts, be sure to use parts of the correct specifications. Never use parts other than the specified ones.



Opening inside the machine shall be done by machine specialist only as high electric current is being sent inside. For game machine with monitor, a care should be taken while opening its back door. If not, a damage to the inside parts or the monitor may occur.



If the sub power switch of the service panel is turned OFF without turning OFF the main power switch of the power supply unit, some parts in the units remain live. When opening the back door, be sure to turn OFF the main power switch and unplug the power cord from the receptacle.



Strictly refrain from disassembly and repair of parts which are not indicated in this manual, as well as settings and remodeling.



To clean the game machine, wipe it with a soft cloth dampened in a neutral detergent.

- Using thinner or other organic solvent or alcohol may decompose the material.
- Electrical shock or equipment failure could be caused by water entering the inside of the machine.

## ⚠ CAUTION

Components in the game are sensitive to vibrations and impact. Care should be used when moving and transporting the game machine.



Be sure not to let the machine tip over.

Before moving the machine, be sure to turn OFF the main power switch, unplug the power cord from the receptacle and remove the power cord from the machine.



Before moving take the machine, off the levelers and move it on the casters.

Avoid excessive force while moving the machine.

.....

## PRECAUTIONS IN HANDLING

- When setting up, inspecting, maintaining, moving or transporting this product, follow the procedures and instructions set forth in this manual and perform such work safely.
- Do not set up, handle, inspect, maintain, move or transport this product under conditions equivalent to the condition of "WARNING" or "CAUTION" specified in this manual.
- If a new owner is to have this product as a result of transfer, and etc., be sure to give this manual to the new owner.

# PRÉCAUTION D'EMPLOI

Les consignes de sécurité suivantes sont données dans ce manuel. Elles doivent être strictement suivies pour protéger ceux qui les installent. Utiliser ou entretenir ce produit pour la sécurité des utilisateurs, des visiteurs et des biens.

Pour des raisons de sécurité.

- **Les suggestions suivantes doivent être respectées:**

## **ATTENTION**

Le non-respect peut entraîner des blessures graves.

## **PRUDENCE**

Le non-respect peut entraîner des blessures ou des dommages au produit.

- **Les suggestions graphiques suivantes décrivent les types de précautions à prendre.**



Indique qu'attention est requise.



Interdit.



Indique que quelque chose doit être effectuée.

- **Les précautions à prendre :**

**Certaines procédures exigent une personne de maintenance qualifiée en atelier ou un spécialiste de l'industrie. Pour ces instructions, une personne qualifiée doit prendre soin des travaux.**

- Sinon, un choc électrique, un dysfonctionnement de la machine, ou un accident grave peut en résulter.
- Remplacement des pièces de machines, l'inspection et la maintenance des machines, et le dépannage doit être attribué qu'à une personne de maintenance qualifiée en atelier ou spécialiste de l'industrie. Cette brochure donne des instructions que les emplois dangereux, en particulier, doivent être traités par un spécialiste de l'industrie. La personne de maintenance qualifiée en atelier et le spécialiste de l'industrie sont définis comme suit.

### **La personne de maintenance qualifiée en atelier**

- Un personnel de service doit avoir de l'expérience dans les opérations de machines de jeux. Le personnel est responsable pour l'assemblage, l'installation, l'inspection et l'entretien de la machine.

### **Le spécialiste de l'industrie**

- Un spécialiste de l'industrie doit être engagé dans la conception, la fabrication, l'inspection et l'entretien des appareils d'amusement.  
Il ou elle doit avoir une formation en génie électrique, électronique et mécanique, et de maintenir régulièrement et de réparer les appareils d'amusement.

# PRÉCAUTION D'EMPLOI

## ATTENTION

Si il y a une anomalie comme fumée, mauvaise odeur ou bruit anormal émis par la machine,  couper immédiatement l'interrupteur principal et débranchez le câble d'alimentation de la prise pour arrêter son fonctionnement.

- L'utilisation de l'appareil dans des conditions anormales peut provoquer un incendie ou un accident.

En cas d'anomalie

1. Mettez l'interrupteur principal sur ARRÊT.
2. Débranchez le câble d'alimentation de la prise.
3. Contactez votre revendeur le plus proche.

**Ne pas brancher le câble d'alimentation incorrectement ou le laisser être recouvert de poussière.** 

Cela pourrait nuire le câble d'alimentation.

## PRUDENCE

**Ne pas utiliser ce produit ailleurs que dans les zones industrielles.** 

- L'utiliser dans une zone résidentielle ou d'une zone à côté d'un quartier résidentiel pourrait nuire à la réception des radios, téléviseurs, téléphones, etc.
- Ne donnez pas de choc à la surface d'un produit en verre.

- S'il vous plaît ne pas jouer à ce jeu.
  - Quand vous buvez;
  - Lorsque votre condition physique n'est pas normale;
  - Lorsque vous êtes dans une période de grossesse;
  - Lorsque vous avez un contrôleur d'impulsion;
  - Lorsque vous avez récemment subi une crampe ou évanouissement en regardant la télévision.
- Évitez une force excessive / un choc pendant la lecture / de déplacer le jeu.
- Quand vous jouez les jeux, faites attention aux alentours.

**Ne pas brancher ou débrancher le câble d'alimentation avec les mains mouillées.** 

**Dans la manipulation du câble d'alimentation, suivez les instructions ci-dessous.** 

- |  |   |
|--|---|
| • Ne pas endommager le câble d'alimentation.                 | • Ne pas modifier le câble d'alimentation.            |
| • Ne pas plier le câble d'alimentation de manière excessive. | • Ne tordez pas le câble d'alimentation.              |
| • Ne pas chauffer le câble d'alimentation.                   | • Ne tirez pas sur le câble d'alimentation.           |
| • Ne pas lier le câble d'alimentation.                       | • Ne montez pas sur le câble d'alimentation.          |
| • Ne pas prendre en sandwich le câble d'alimentation.        | • Ne pas mettre un clou dans le câble d'alimentation. |

**Si la fiche du câble d'alimentation ou est endommagé, cessez immédiatement d'utiliser la machine et demandez à votre revendeur le plus proche de remplacer les pièces.**

# PRÉCAUTION D'EMPLOI

## ATTENTION

**Assurez-vous de consulter un spécialiste de l'industrie lors de la mise en place, du déplacement ou le transport de ce produit.**

- Ce produit ne doit pas être mis en place, déplacé ou transporté par une quelconque autre qu'un spécialiste de l'industrie.
- Lors de l'installation de ce produit, installez 4 niveleurs de pieds uniformément sur le sol et assurez-vous que le produit est installé de façon stable dans une position horizontale. Une installation instable peut entraîner des blessures ou un accident.
- Lors de l'installation de ce produit, ne pas appliquer une force excessive sur les pièces mobiles. Sinon, des blessures et des accidents peuvent y résulter, ou le produit peut être endommagé.

**La machine pour une utilisation en intérieur uniquement, ne pas installer à l'extérieur.**



**N'installez pas la machine de jeu près des issues de secours.**



**Protéger la machine de jeu de:**



- L'humidité ou la pluie.
- La lumière directe du soleil.
- La chaleur directe de la climatisation et du chauffage, etc...
- Des substances inflammables dangereuses.
- Sinon, un accident ou un dysfonctionnement.

**Ne pas placer les récipients contenant des produits chimiques ou de l'eau sur ou près de la machine de jeu.**



**Ne placez pas d'objets à proximité des orifices de ventilation.**



**Ne pas plier le cordon d'alimentation par la force ou de placer des objets lourds au-dessus.**



**Ne jamais brancher ou débrancher le cordon d'alimentation avec les mains mouillées.**



**Ne jamais débrancher la machine de jeu en tirant le câble d'alimentation.**



## PRUDENCE

**Veillez à utiliser le câblage intérieur selon les exigences de tension spécifiées. Pour une rallonge, utilisez la notation spécifiée ou plus.**

**Veillez à utiliser le cordon d'alimentation fourni.**

**Ne jamais brancher plus d'un cordon à la fois dans la prise électrique.**



**Ne pas poser le cordon d'alimentation où les gens marchent à travers.**



**Soyez sûr de mettre à la terre ce produit.**



**Ne pas exercer une force excessive lors du déplacement de la machine.**





**Pour une ventilation correcte, garder la machine de jeu 100mm (4 ") loin des murs.**

**Ne pas modifier les réglages des commutateurs DIP liées au système.**

# PRÉCAUTION D'EMPLOI

## ATTENTION

Veillez à éteindre l'interrupteur d'alimentation principale et débranchez le cordon d'alimentation de la prise avant d'inspecter ou de nettoyer la machine. 

Lors du remplacement des pièces, veillez à utiliser une partie des spécifications correctes. Ne jamais utiliser de pièces autres que celles spécifiées. 

L'ouverture à l'intérieur de la machine doit être effectuée par le spécialiste de la machine seulement, comme le courant électrique élevé est transmis à l'intérieur. Pour la machine de jeu avec le moniteur, un soin doit être pris lors de l'ouverture de sa porte arrière. Si non, une détérioration des pièces à l'intérieur ou à l'écran peut se produire. 

Si l'interrupteur secondaire du panneau de service est éteint sans éteindre le commutateur d'alimentation principale de l'unité d'alimentation, certaines parties dans les unités restent sous tension. Lors de l'ouverture de la porte arrière, veillez à éteindre l'interrupteur d'alimentation principale et débranchez le cordon d'alimentation de la prise. 

Il est strictement conseillé de s'abstenir de démonter et de réparer des pièces qui ne sont pas indiqués dans ce manuel, ainsi que les paramètres et le remodelage. 

Pour nettoyer la machine de jeu, l'essuyer avec un chiffon doux imbibé avec un détergent neutre.

- L'utilisation plus mince d'un autre solvant organique ou de l'alcool peut décomposer le matériel.
- Un choc électrique ou une défaillance de l'équipement pourraient être causés par la pénétration de l'eau à l'intérieur de la machine.

## PRUDENCE

Les composants de la machine de jeu sont sensibles aux vibrations et aux chocs. Il faut faire attention lors du déplacement et le transport de la machine de jeu. 

Veillez à ne pas laisser la machine se renverser.

Avant de déplacer la machine, veillez à éteindre l'interrupteur d'alimentation principale, débranchez le cordon d'alimentation de la prise et débranchez le cordon d'alimentation de la machine. 

Avant de déplacer la machine, la mettre hors des niveleurs et le déplacer sur les roulettes.

Éviter une force excessive lors du déplacement de la machine.

.....

## PRÉCAUTIONS LORS DU MANIEMENT

- Lors de la mise en place, l'inspection, l'entretien, déplacement ou le transport de ce produit, suivez les procédures et les instructions énoncées dans ce manuel et effectuer ce travail en toute sécurité.
- Ne pas mettre en place, manipuler, inspecter, entretenir, déplacer ou transporter ce produit dans des conditions équivalentes à l'état de "ATTENTION" ou "PRUDENCE" spécifiée dans ce manuel.
- Si un nouveau propriétaire obtient ce produit à la suite d'un transfert, etc., soyez sûr de donner ce manuel au nouveau propriétaire.



5-14. CARD DISPENSER ERROR [E.81]	P57
5-15. CARD DISPENSER ERROR [E.81]	P59
5-16. SOUND ERROR	P61
5-17. LED PCB OR FND ERROR	P63
5-18. 2813 LED PCB ERROR	P64
<b>6. EXPLODED VIEW</b>	P65
6-1. MAIN CABINET PART	P65
6-2. BILLBOARD PART	P66
6-3. SPEAKER PART	P67
6-4. BUTTON PANEL PART	P68
6-5. BONUS DISPLAY PART	P69
6-6. BONUS TARGET PART	P70
6-7. PIN BASE PART	P71
6-8. PIN BASE PART - 01	P72
6-9. BALL ELEVATOR RAIL PART	P73
6-10. BILLBOARD BODY PART	P74
6-11. CARD DISPENSER PART	P75
6-12. CARD DISPENSER COVER PART	P76
6-13. CABINET MIDDLE REAR FRAME PART	P76
6-14. CARD CONVEYOR PART	P77
6-15. MONITOR PLATE-L PART	P78
6-16. SIDE DISPLAY LOWER COVER BKT PART	P79
6-17. MONITOR PLATE LOWER COVER PART	P79
6-18. FRONT UPPER DOOR PART	P80
6-19. WOOFER SPEAKER PART	P81
6-20. FRONT LOWER DOOR PART	P81
6-21. TICKET DOOR PART	P82
6-22. SMPS PART	P83
6-23. MAIN BOARD PART	P83
6-24. AC INPUT PART	P84
6-25. CONTROL PANEL PART	P84
<b>7. PART PICTURE</b>	P85
<b>* HOW TO ADJUST THE GAP OF CARD DISPENSNER</b>	P92
<b>8. BLOCK DIAGRAM</b>	P94

# CONTENTS

---

<b>1. SPECIFICATION AND DIMENSION</b>	P03
1-1. DIMENSION	P03
1-2. SPECIFICATION	P03
1-3. NAME OF PARTS	P04
1-4. STICKER LOCATION	P05
1-5. COMPONENTS	P06
<b>2. INSTALLATION</b>	P07
2-1. INSTALLATION SPACE	P07
2-2. HOW TO INSTALL	P08
<b>3. GAME CHARACTERISTICS</b>	P10
<b>4. SETUP SETTINGS</b>	P11
4-1. MACHINE SETUP	P11
4-2. SETUP MODE	P12
4-3. CLEAR MODE	P19
4-4. TEST MODE	P21
4-5. FIELD MODE	P26
4-6. ERROR CODE	P28
4-7. ERROR CODE DETECTION METHOD	P30
<b>5. TROUBLESHOOTING</b>	P32
5-1. SERIAL COMMUNICATION ERROR [E.21]	P32
5-2. MAIN CHECKER MOTOR ERROR [E.31]	P33
5-3. MAIN CHECKER MOTOR ERROR [E.31]	P35
5-4. MAIN CHECKER SENSOR ERROR [E.35]	P37
5-5. CARD BELT MOTOR ERROR [E.41]	P39
5-6. CARD BELT MOTOR ERROR [E.41]	P41
5-7. CARD DROP SENSOR [E.43, E.44]	P43
5-8. PIN SWING MOTOR ERROR [E.51]	P45
5-9. PIN SWING MOTOR ERROR [E.51]	P47
5-10. PIN GOAL-IN HOLE SENSOR ERROR [E.71~77]	P49
5-11. BALL ELEVATOR JAM ERROR [E.61]	P51
5-12. BALL ELEVATOR JAM ERROR [E.61]	P53
5-13. BALL ELEVATOR SENSOR ERROR [E.62]	P55

# 1. SPECIFICATION AND DIMENSION

## 1-1. DIMENSION

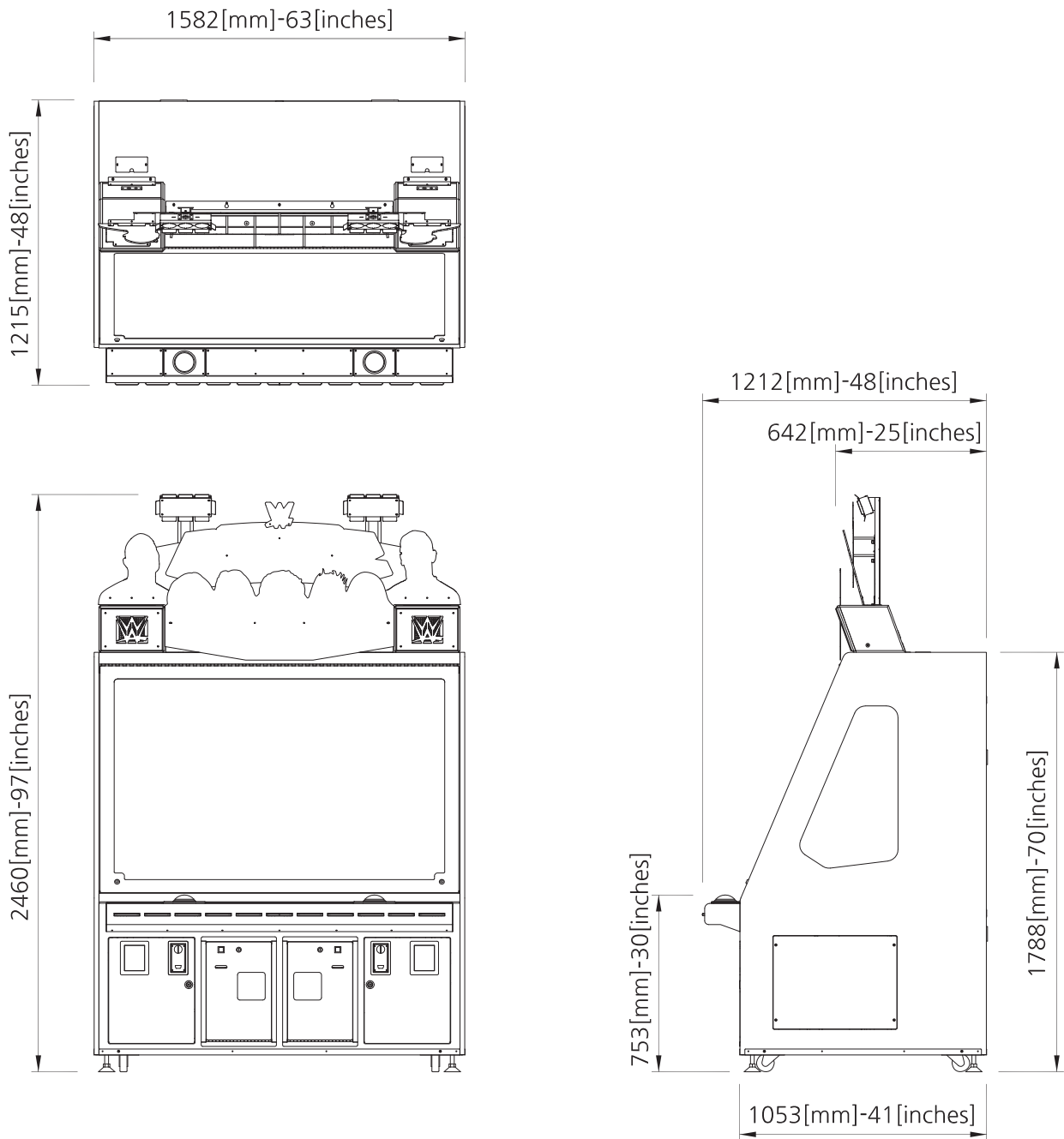

## 1-2. SPECIFICATION

DIMENSION (W x D x H)	1582 x 1212 x 2460 (mm)	
PACKING DIMENSION (W x D x H)	1700 x 1150 x 2200 (mm)	
WEIGHT (kg)	460 kg [ WEIGHT INCLUDING : 515 kg ] PACKAGING	
VOLTAGE	AC 120V	AC 230V
FREQUENCY RANGE	60Hz	50,60Hz
CONSUMPTION	530 W	530 W
CERTIFICATION	-	

### 1-3. NAME OF PARTS

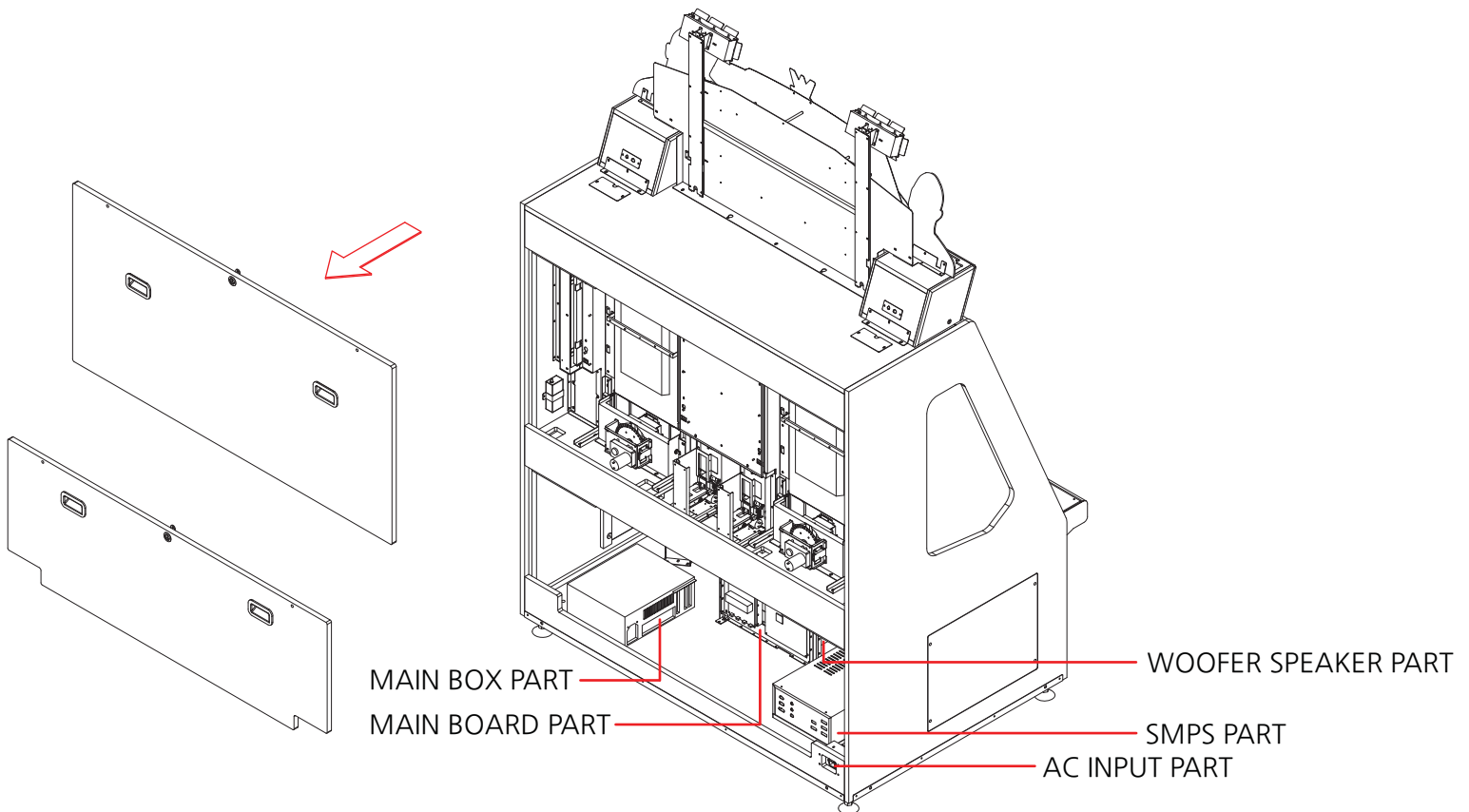
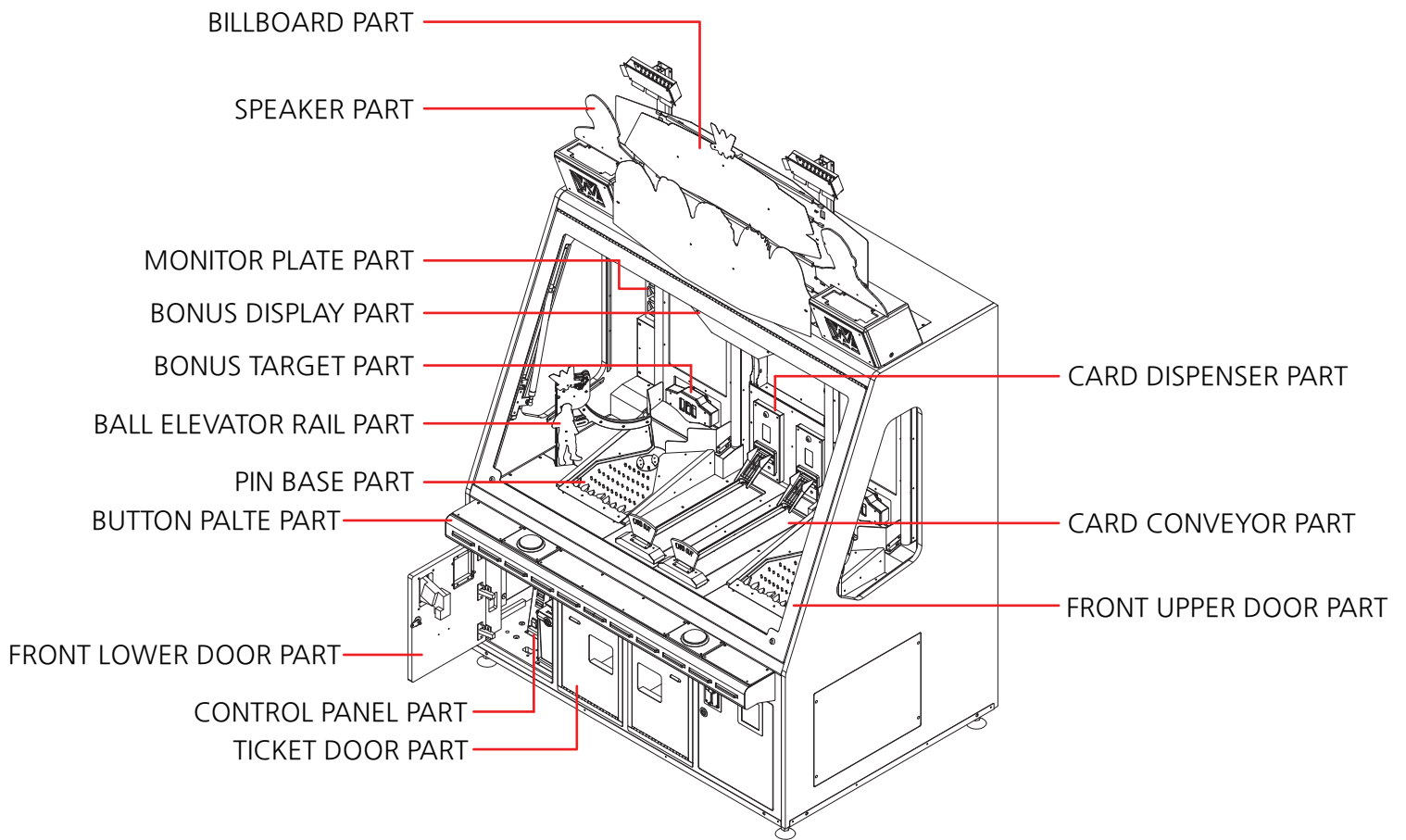

# 1-4. STICKER LOCATION

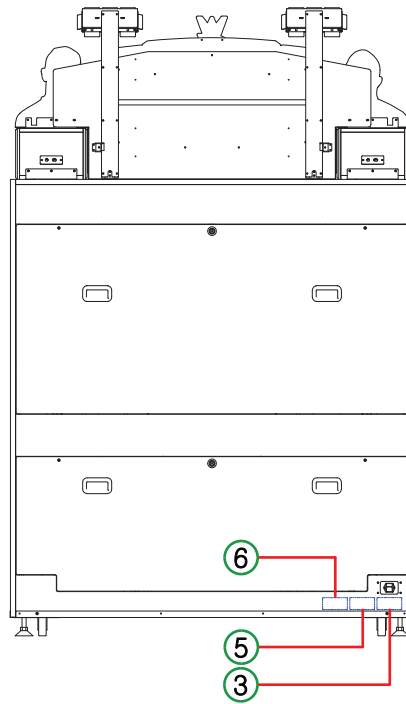
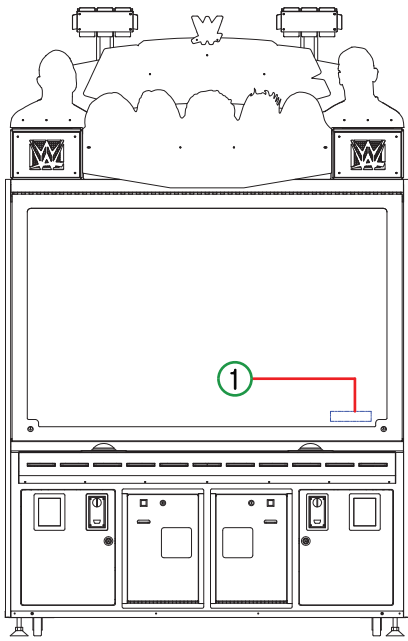
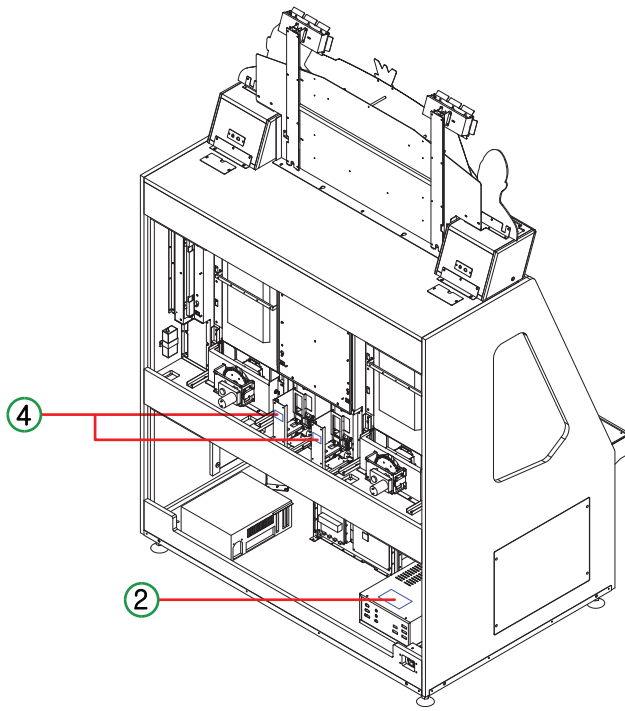

1

**CAUTION/PRUDENCE**  
 Do not push or hit this. It would be damaged.  
 Ne pas la pousser ou frapper. Elle serait endommagée.

2

**WARNING/ATTENTION**  
 Except service personal, please never open the product as there is a risk of electric shock.  
 Il y a un risque d'électrocution, n'ouvrez pas le produit excepté le responsable, s'il vous plaît.

3

**CAUTION/PRUDENCE**  
 \*For continuous protection against risk of fire, replace only with the same type 10A-250V fuse\*  
 \*Pour une protection continue contre les risques d'incendie, remplacer un fusible avec seulement le même type 10A-250V\*

4

**NOTICE**  
 Before loading new cards, shuffle all cards properly.

5











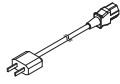











6

MODEL NAME	-
PRODUCT S/N	-
MAIN BOX S/N	-
LOD S/N	-
CERTIFICATE	-
MADE IN KOREA	
Koyuncu-si, Kyounggi-do, Korea. Phone:82-31-909-2100	



## 1-5. COMPONENTS

NO.	PART NAME	SPEC.		QTY
1	AC POWER CORD	-		1
2	KEY	6001, 7001		2 EACH
3	BOLT [ NI ]	4x8L		9
4	BOLT [ NI ]	4x16L		8
5	BOLT [ NI ]	4x20L		14
6	BOLT [ NI ]	4x25L		10
7	BOLT [ BLACK ]	4x8L		13
8	BOLT [ BLACK ]	4x10L		8
9	BOLT [ WRENCH ]	4x10L		9
10	BOLT [ WRENCH ]	4x12L		10
11	BOLT [ WRENCH ]	4x16L		10
12	SEMS BOLT	6x25L		6
13	BOLT	6x25L		6
14	WRENCH	2.5 / 3 / 4 mm		1 EACH
15	CABLE TIE	-		5
16	CARD SETTING JIG	-		1
17	CARD HEAVY PUSH BKT	-		2
18	COIN SELECTOR BKT_CLOSE	-		1
19	MANUAL	-		1
20	TROUBLE SHOOTING MANUAL	-		1

## 2. INSTALLATION

### 2-1. INSTALLATION SPACE

- Need to have installation place.  
Maintenance zone & Play zone should have at least 2500mm x 2000mm each.

#### **\*IMPORTANT**

- Once you set up the machine with required game-play area, when installing this product, set the 4 leg levelers evenly on the floor and make sure that the product is installed stably in a horizontal position.

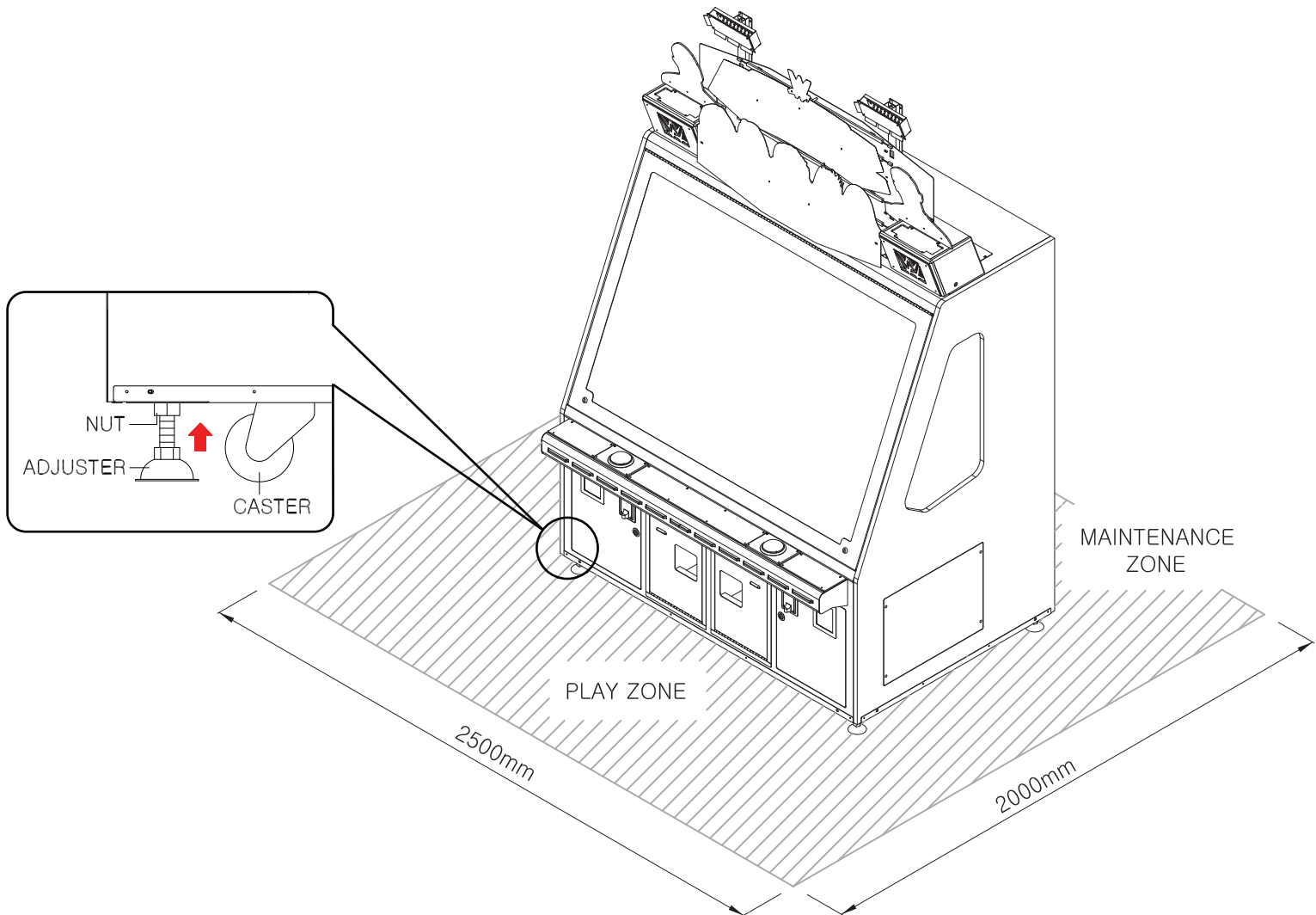

## 2-2. HOW TO INSTALL

### 1 \* BILLBOARD

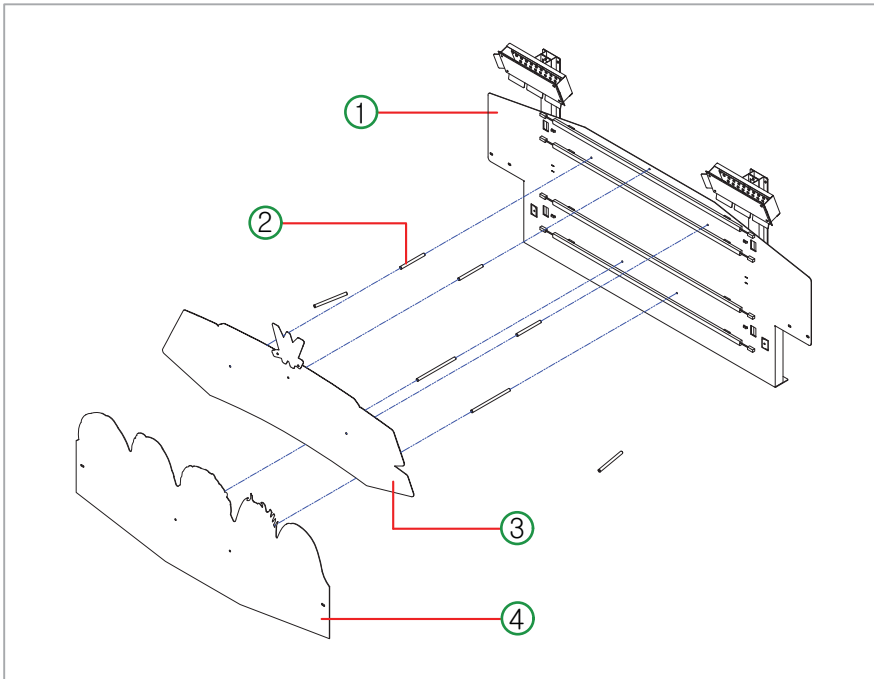

- Please assemble in order of pictures from ① to ⑬

\* Connector assembly when assembling ⑩, ⑪, ⑬

### \* SPEAKER L, R

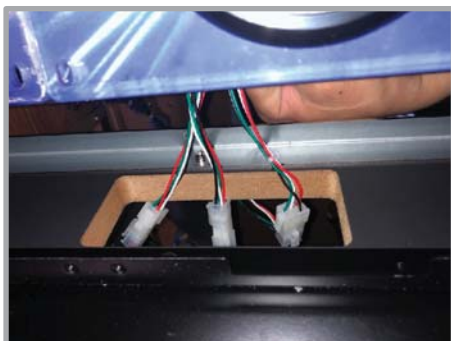
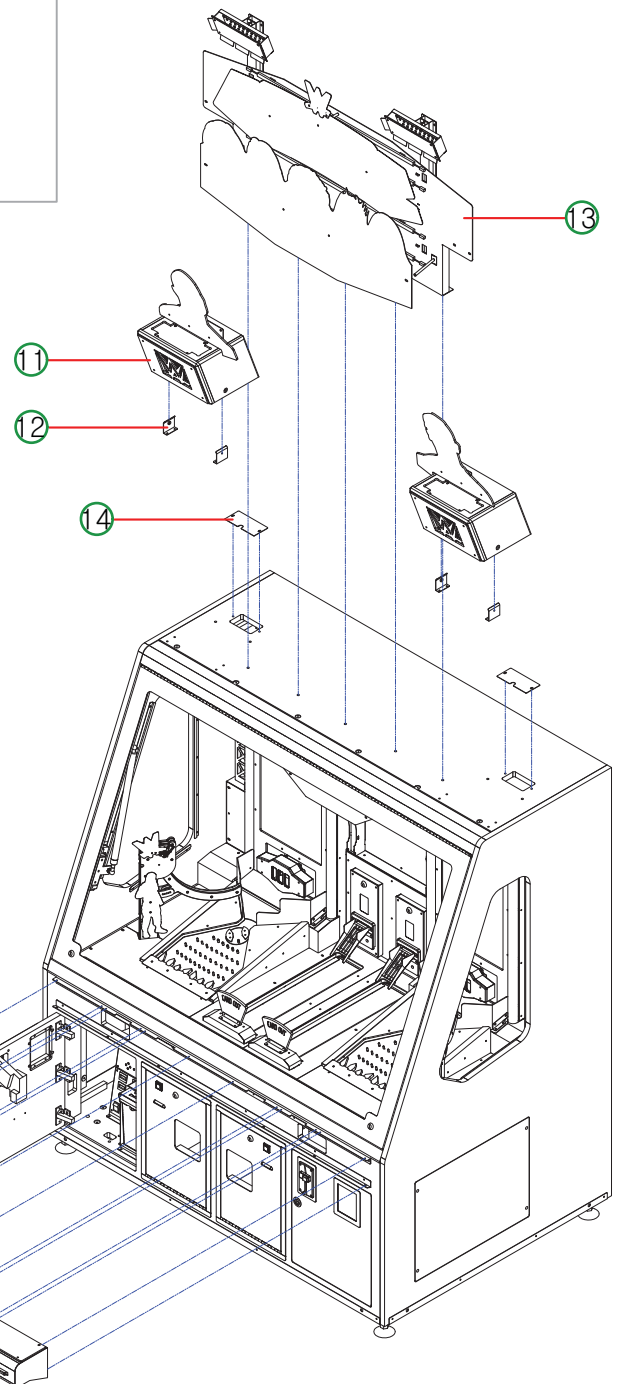
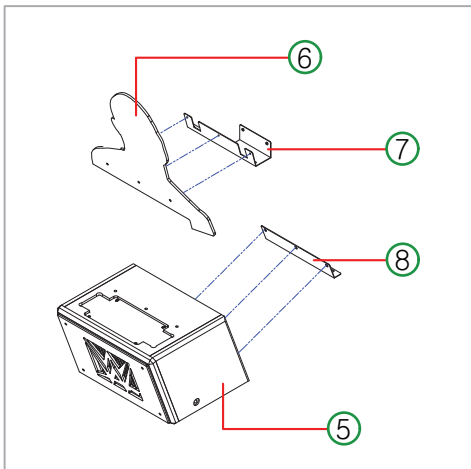

**2** - You complete it like picture.

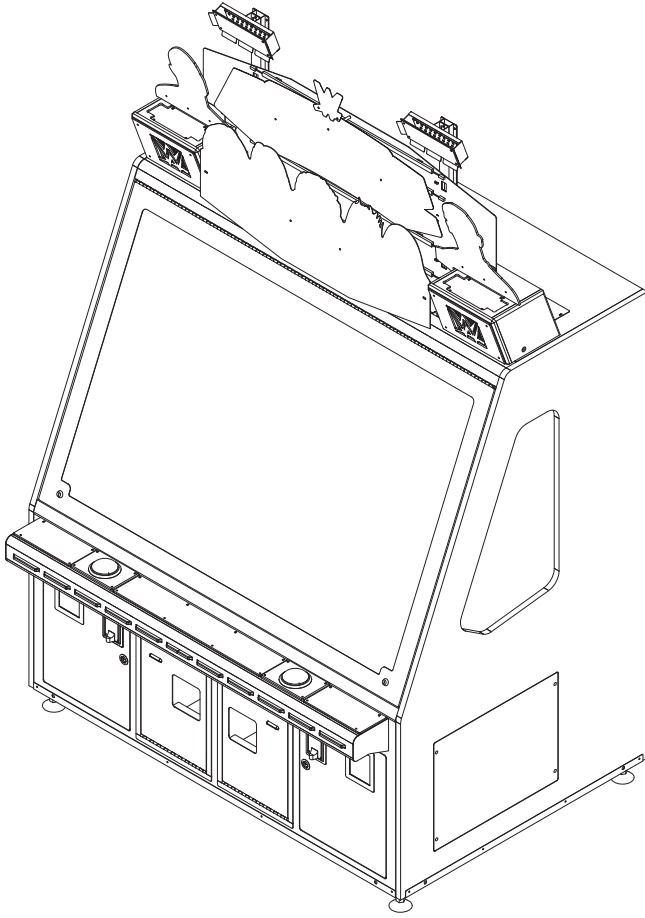

### 3. GAME CHARACTERISTICS

---

**\* ALL THE CARDS ARE SUPERSTARS!**

- Easy and exciting play
- Powerful ball action
- Two player stations
- Collectible card set of 7 for super bonus

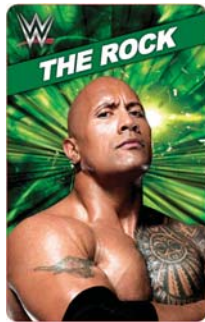
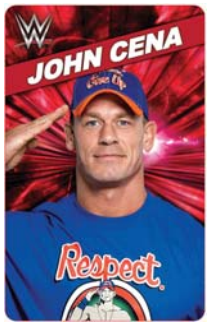

- Collectible legend card

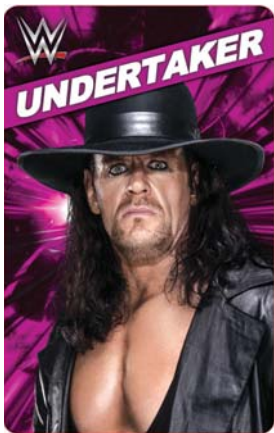



# 4. SETUP SETTING

## 4-1. MACHINE SETUP

### 1. SETUP BUTTON LAYOUT

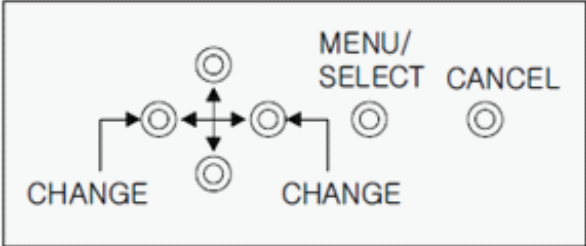
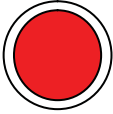
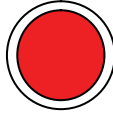
	<ol style="list-style-type: none"> <li>1) [↑↓] Up/Down Button : Menu Up/Down Move</li> <li>2) [←→] Left/Right Button : Setting Value Change</li> <li>3) Menu/Select Button : Execution of Set Up Menu Mode and Select</li> <li>4) Cancel Button : Exit</li> </ol>
<div style="display: flex; justify-content: space-around; align-items: center;"> <div style="text-align: center;">  <p>1P SERVICE / RESET</p> </div> <div style="text-align: center;">  <p>2P SERVICE / RESET</p> </div> </div>	<p>Normally SERVICE IN, In case Error occurs, use this button to terminate Error.</p> <p>SERVICE IN :increases by 10 plays per one press.</p>

### [ OPERATING OPTIONS ]

OPERATING OPTIONS	
Press MENUButton [MENU/SELECT Button: Enter]	
PROGRAM SETTINGS	Set Up Mode
CLEAR MODE	Delete Mode
BOOKKEEPING	Check Game Data
FACTORY SETTING	Initializing to Factory Setting
TEST MODE	Test Mode
FIELD TEST	Exclusive test for ball shooting and sensor check status
EXIT	Exit from Operation Options

## 4-2. SETUP MODE

PROGRAM SETTINGS			
LCD DISPLAY	Descriptions	Range	Default
PLAYS / COIN ※ DIP	- Selection of Setting to use Coin or Card and Free Play  - Setting Plays (Credits) per Coin Differential payment according to the number of continued plays in case of coin or using swipe card	=> (Sub Menu) (Refer to #1 below)	
PLAYS / BILL ※ DIP	Setting Plays (Credits) per Bill Input Differential payments according to Input amount of Bill.	=> (Sub Menu) (Refer to #2 below)	
CONTINUE PLAY ※ DIP	Function to restrict inputting continue credit while playing the game (Setting Coin Inhibit)  "OFF": Restrict Coin or Swipe up to max 5 times and No permission for new coins until plays "0" after starting the game  "ON" : No limit for max input of Coin and Swipe and always permit new coin input regardless of playing the games	"OFF", "ON"	"OFF"
SHOT INTERVAL	Waiting time for shooting (in seconds)	0.3 ~ 1.0 (sec)	0.3
SCORE TYPE ※ DIP	Setting FND Ticket Score at lower Pin game  <b>Notice: Setting Value will not be changed against factory setting</b>	=> (Sub Menu) (Refer to #3 below)	
CHECKER SPEED	Setting the speed of main checker "RAND" : Move at a Random Speed based on New Play (If new credit is input when Plays become "0", it changes to Random Speed and the speed is fixed by the time plays0)  "SLOW" : Move at a SLOW speed "NORM" : Move at a NORMAL speed "FAST" : Move at a FAST speed "STEP" : Speed increases at each step according to the number of card stock at Main Checker  Ex) 0 step : Slow 1 <sup>st</sup> step : a little bit slow 2 <sup>nd</sup> step : Normal 3 <sup>rd</sup> step : a little bit fast 4 <sup>th</sup> step : fast	"RAND" "SLOW" "NORM" "FAST" "STEP"	RAND

<b>CARD OUT STOCK</b> ※ <b>DIP</b>	Setting the success number of main checker to release card Release cards when making success to main checker as many as given number 3~7 : Accumulated maximum number	3 ~ 7	<b>7</b>
<b>MULTIBALL STOCK</b> ※ <b>DIP</b>	When getting through to the hole in the center, success number is accumulated by one and then "Multi-Ball Event (shooting the ball free of charge)" shall be proceed if it reaches the setting number 3 ~ 7 : Accumulated maximum number	3 ~ 5	<b>3</b>
<b>MULTIBALL COUNT</b>	Number of balls to be shot during Multi-Ball Event	1 ~ 15 (to be increased by 1)	<b>10</b>
<b>TICKET/SCORE</b>	Setting the ticket ratio per score NONE: Automatic reduction of ticket count without releasing tickets	"NONE", "1/1", "1/2"	<b>1/1</b>
<b>ATTRACT VOLUME</b>	Use of DEMO Sound and Volume setting "OFF" : No Sound 10 ~ 100 : Ratio of Sound Volume	"OFF" , 10 ~ 100 (increased by 10)	<b>60</b>
<b>ELEVATOR SETTING</b>	Setting minute functions of ball shooting elevator Time-Setting for ball shooting and stopping motor  <b>Notice: Setting Value will not be changed against factory setting</b>	=> (Sub-Menu) (Refer to #4 below)	
<b>HOW TO PLAY</b>	Functions to show "How to Play" prior to starting game "ON", "OFF" : Proceed as per the selection "OFF" : Non-display for How to Play "ON" : Showing "How to Play" and then Skipped by pressing the button	"OFF", "ON"	"ON"

MULTISTEP CHAN~	<p>Option for Multi Ball Event Maximum Step Change  "OFF" : Disabling the optional functions  "ON" : Enabling the optional functions for maximum step change</p> <p>Ex) In case of setting Multi Ball Stock 3, After performing Multi Ball Event, the maximum step of Multi Ball changes to 2nd step and then changes to 3rd step again repeatedly after performing next Multi Ball Event</p> <p>(After performing Multi Ball Event, the maximum step for next Multi Ball changes from 3rd step to 2nd step and changes from 2nd step to 3rd step repeatedly.)</p> <p><b>(This function is applied only when Setting Value of Multi Ball Stock is over 3)</b></p>	"OFF", "ON"	"OFF"
DEMO VIDEO	<p>Setting for the use or non-use of demo video presentation</p> <p>"ON" - VIDEO PRESENTATION INCLUDING PLAYERS  "OFF" - VIDEO PRESENTATION FOR HOW TO PLAY ONLY WITHOUT PLAYERS</p>	"OFF", "ON"	"ON"
SAVE AND EXIT	Save and Exit	Press SELECT Button and then execute by moving to [YES] or [NO]	
CANCEL AND EXIT	Cancel and Exit		
<p><b>* According to setting of DIP S/W(KSD08H) #3 and #4, default value of DIP S/W display can be different.  For more details, please refer to following DIP S/W setting default value.</b></p>			

## <DIP S/W SETTING DEFAULT VALUE>

★ When factory setting, basic default value can be different according to setting of DIP S/W #3 and #4 (KSD08H 8 PCS)  
(Refer to the location of arrow in yellow color of DIP S/W in the photo)

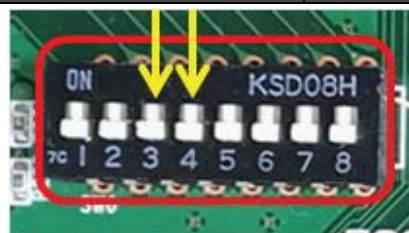

※ According to DIP S/W setting, It separates as A, B, C and D type.

	A		B		C		D	
DIP 3	OFF		ON		OFF		ON	
DIP 4	OFF		OFF		ON		ON	
PLAYS / COIN	PAYMENT TYPE	Card	PAYMEN TYPE	Card	PAYMEN TYPE	Card	PAYMEN TYPE	Coin
	MININUM COIN	1	MININUM COIN	1	MININUM COIN	1	MININUM COIN	1
	1st. COIN	10	1st. COIN	10	1st. COIN	2	1st. COIN	1
	2nd. COIN	22	2nd. COIN	22	2nd. COIN	4	2nd. COIN	2
	3rd. COIN	36	3rd. COIN	36	3rd. COIN	6	3rd. COIN	3
	4th. COIN	50	4th. COIN	50	4th. COIN	8	4th. COIN	4
	5th. COIN	65	5th. COIN	65	5th. COIN	10	5th. COIN	5
PLAYS / BILL	TYPE	Bill	TYPE	Bill	TYPE	Bill	TYPE	Bill
	1 BILL or COIN	10	1 BILL or COIN	10	1 BILL or COIN	2	1 BILL or COIN	1
	2 BILLS or COINS	22	2 BILLS or COINS	22	2 BILLS or COINS	4	2 BILLS or COINS	2
	3 BILLS or COINS	36	3 BILLS or COINS	36	3 BILLS or COINS	6	3 BILLS or COINS	3
	4 BILLS or COINS	50	4 BILLS or COINS	50	4 BILLS or COINS	8	4 BILLS or COINS	4
	5 BILLS or COINS	65	5 BILLS or COINS	65	5 BILLS or COINS	10	5 BILLS or COINS	5
	10 BILLS or COINS	130	10 BILLS or COINS	130	10 BILLS or COINS	20	10 BILLS or COINS	10
	20 BILLS or COINS	260	20 BILLS or COINS	260	20 BILLS or COINS	40	20 BILLS or COINS	20
	50 BILLS or COINS	650	50 BILLS or COINS	650	50 BILLS or COINS	100	50 BILLS or COINS	50
	100 BILLS or COINS	1300	100 BILLS or COINS	1300	100 BILLS or COINS	200	100 BILLS or COINS	100
CONTINUE PLAY	OFF		OFF		OFF		ON	
CARD OUT STOCK	7		7		5		5	
MULTIBALL STOCK	3		3		3		5	
SCORE TYPE	TYPE	8	TYPE	6	TYPE	3	TYPE	4
	MAIN CHECKER	2	MAIN CHECKER	2	MAIN CHECKER	2	MAIN CHECKER	0
	HOLE 1	6	HOLE 1	4	HOLE 1	2	HOLE 1	3
	HOLE 2	2	HOLE 2	3	HOLE 2	2	HOLE 2	2
	HOLE 3	4	HOLE 3	2	HOLE 3	2	HOLE 3	1
	HOLE 4(ENVENT)	2	HOLE 4(ENVENT)	2	HOLE 4(ENVENT)	2	HOLE 4(ENVENT)	0
	HOLE 5	4	HOLE 5	2	HOLE 5	2	HOLE 5	1
	HOLE 6	2	HOLE 6	3	HOLE 6	2	HOLE 6	2
HOLE 7	6	HOLE 7	4	HOLE 7	2	HOLE 7	3	



<TABLE # 1>

● PROGRAM SETTINGS -> PLAYS / COIN ✧ SETTING PLAYS (CREDITS) PER COIN or SWIPE When swiping or inputting coin continuously without playing, it increases up to five times as follows and it shall be applied to the 1 <sup>st</sup> coin value from the 6 <sup>th</sup> times (based on five times)			
LCD DISPLAY	DESCRIPTIONS	RANGE	DEFAULT
PAYMENT TYPE	Select the wording on the monitor between Insert Coin or Swipe Card on the monitor. "FREE" - Free Play "COINS" - Insert Coin "CARD" - Swipe Card	"FREE" "COINS" "CARD"	"CARD"
MINIMUM COIN	Setting minimum number of coins to play which is to be all applied to following setting values ex) In case of setting minimum 5 coins, when inputting 5 coins, it pays 10 plays as a 1 <sup>st</sup> coin value	1 ~ 9 (increase by 1)	1
1st. COIN	Setting number of plays per coin	1 ~ 300 (increase by 1)	10
2nd. COIN	Setting number of plays per coin		22
3rd. COIN	Setting number of plays per coin		36
4th. COIN	Setting number of plays per coin		50
5th. COIN	Setting number of plays per coin		65
SAVE AND EXIT	Save and Exit	Press SELECT Button and then execute by moving to [YES] or [NO]	
CANCEL AND EXIT	Cancel and Exit		

<TABLE # 2>

● PROGRAM SETTINGS -> BILLS / COIN ✧ SETTING PLAYS (CREDITS) PER BILL IT INCREASES AS FOLLOWING VALUE IN GEARING WITH SIGNALS FROM BILL COLLECTOR			
LCD DISPLAY	DESCRIPTIONS	RANGE	DEFAULT
TYPE	When using Coin selector or Bill collector, it sets in gearing with signals from Bill collector EX) Setting as a coin by installing coin selector to the signal line from bill collector	COIN, BILL	BILL
1 BILL or COIN	Setting number of plays per 1.00\$	1 ~ 3000 (to be increased by 1)	10
2 BILLS or COINS	Setting number of plays per 2.00\$		22
3 BILLS or COINS	Setting number of plays per 3.00\$		36
4 BILLS or COINS	Setting number of plays per 4.00\$		50
5 BILLS or COINS	Setting number of plays per 5.00\$		65
10 BILLS or COINS	Setting number of plays per 10.00\$		130
20 BILLS or COINS	Setting number of plays per 20.00\$		260
50 BILLS or COINS	Setting number of plays per 50.00\$		650
100 BILLS or COINS	Setting number of plays per 100.00\$		1300

SAVE AND EXIT	Save and Exit	Press SELECT Button and then execute by moving to [YES] or [NO]
CANCEL AND EXIT	Cancel and Exit	

<TABLE # 3>

<p>● PROGRAM SETTINGS -&gt; SCORE TYPE</p> <p>◇ SETTING WIN TICKET SCORE AND INDIVIDUAL TICKET SCORE AT LOWER BONUS GAME</p> <p>※ HOLE #4 EVENT HOLE: MULTI-BALL EVENT WILL PROCEED WHEN BALLS DROP AS MANY AS THE NUMBER SET IN MULTI BALL STOCK IN PROGRAM SETTING</p>			
LCD DISPLAY	DESCRIPTION	RANGE	DEFAULT
TYPE	Set value referred to the set score table which was basically set internally	1 ~ 9 (to be increased by 1)	8
MAIN CHECKER	Set score to pay when making success to the hole of main checker	"0 ~ 99" (to be increased by 1)	2
HOLE 1	Set score for the 1 <sup>st</sup> goal in	"BONUS" "0 ~ 99" (to be increased by 1)	6
HOLE 2	Set score for the 2 <sup>nd</sup> goal in		2
HOLE 3	Set score for the 3 <sup>rd</sup> goal in		4
HOLE 4(EVENT)	Set score for the 4 <sup>th</sup> goal in in case of Multi-Ball Event.		2
HOLE 5	Set score for the 5 <sup>th</sup> goal in		4
HOLE 6	Set score for the 6 <sup>th</sup> goal in		2
HOLE 7	Set score for the 7 <sup>th</sup> goal in		6
SAVE AND EXIT	Save and Exit <b>Notice: Setting Value will not be changed against Factory setting</b>	Press SELECT Button and then execute by moving to [YES] or [NO]	
CANCEL AND EXIT	Cancel and Exit		

<INTERNAL SET VALUE ACCORDING TO THE SCORE OF TYPE>

TYPE	1	2	3	4	5	6	7	8	9
MAIN CHECKER	0	2	2	0	2	2	2	2	4
HOLE 1	1	2	2	3	4	4	6	6	8
HOLE 2	1	1	2	2	2	3	2	2	4
HOLE 3	1	1	2	1	2	2	2	4	4
HOLE 4 (EVENT)	0	1	2	0	2	2	2	2	4
HOLE 5	1	1	2	1	2	2	2	4	4
HOLE 6	1	1	2	2	2	3	2	2	4
HOLE 7	1	2	2	3	4	4	6	6	8

<TABLE # 4>

<ul style="list-style-type: none"> <li>● PROGRAM SETTINGS -&gt;ELEVATOR SETTING</li> <li>◇ Detailed settings for motor-stop after shooting the ball in the elevator</li> <li>◇ According to the deviation of specification of elevator motor, it makes ball-elevator motor stop after rotating more as much as time for the next ball loading after shooting the ball</li> </ul>			
Balls go off when pressing the shooting button or select button of each player here			
LCD DISPLAY	DESCRIPTIONS	RANGE	DEFAULT
PLAYER 1	Detailed setting for Ball Elevator Player 1 (in 0.00 seconds)	"0.00" : Immediate Stop "0.02" ~ "0.16" (Change 0.02 seconds)	<b>0.06</b>
PLAYER 2	Detailed setting for Ball Elevator Player 2 (in 0.00 seconds)		
SAVE AND EXIT	Save and Exit <b>Notice: Setting Value will not be changed against Factory setting</b>	Press SELECT Button and then execute by moving to [YES] or [NO]	
CANCEL AND EXIT	Cancel and Exit		

### 4-3. CLEAR MODE

● CLEAR MODE		
✧ GAME DATA AND BOOKKEEPING CAN BE DELETED		
LCD DISPLAY	DESCRIPTIONS	EXECUTION
CLEAR TICKETS	Delete number of ticket to release now	Press SELECT Button and then execute by moving to [YES] or [NO]
CLEAR PLAYS	Delete remaining plays (credits) now Delete all number of cards to release	
CLEAR DATA	Delete game data and bookkeeping data	
EXIT	Exit	

● BOOKKEEPING	
LCD DISPLAY	DESCRIPITONS
1P : 1 Player 2P : 2 Player TOTAL : 1P, 2P Grand Total	
-- COIN IN -- 1P: 0 2P: 0 TOTAL : 0	Number of Coin Input of each player (1P, 2P) and Total Number of Coin Input
-- BILL IN -- 1P: 0 2P: 0 TOTAL : 0	Number of Bill In of each player (1P, 2P) and Total Number of Bill In
-- SERVICE IN -- 1P: 0 2P: 0 TOTAL : 0	Number of Service In and Plays of each player (1P, 2P) and Total number of Service In and Plays (Service Button: to be increased by 10 plays)
-- GAME PLAYS -- 1P: 0 2P: 0 TOTAL : 0	Number of Game Play of each player (1P, 2P) and Total Number of Game Play
-- TICKET OUT -- 1P: 0 2P: 0 TOTAL : 0	Number of Ticket Out of each player (1P, 2P) and Total number of Ticket Out
-- CARD OUT -- 1P: 0 2P: 0 TOTAL : 0	Number of Card Out of each player (1P, 2P) and Total number of Card Out

-- CHECKER WIN -- 1P: 0 2P: 0 TOTAL: 0	Number of Checker WIN (making success to the goal in at Main Belt) of each player (1P, 2P) and Total Checker WIN
- MULTI BALL EVENT - 1P: 0 2P: 0 TOTAL: 0	Number of Multi-Ball Event of each player (1P, 2P) and Total number of Multi-Ball Event
- 1P PIN HOLE GOALIN - HOLE 1 : 0 HOLE 2 : 0 HOLE 3 : 0	1P Number of Goal In Pin Hole #1, #2 and #3
HOLE 4 : 0 HOLE 5 : 0 HOLE 6 : 0 HOLE 7 : 0	1P Number of Goal In Pin Hole #4, #5, #6 and #7
- 2P PIN HOLE GOALIN - HOLE 1 : 0 HOLE 2 : 0 HOLE 3 : 0	2P Number of Goal In Pin Hole #1, #2 and #3
HOLE 4 : 0 HOLE 5 : 0 HOLE 6 : 0 HOLE 7 : 0	2P Number of Goal In Pin Hole #4, #5, #6 and #7
** VER INFO 1 ** MAIN INT-A Ver_.___ MK Ver _.___ LED IO Ver__	Display of Version Information 1 - Main Board Program Version - MK (PC)Program Version - LED IO Board Firm Ware Version
** VER INFO 2 ** CHECKER, PIN HOLE 1P:Ver__, Ver/___ 2P:Ver__, Ver/___	Display of Version Information 2 (Display of Firmware Version of each sensor) Name of Main Checker Sensor, Pin Hole Sensor - 1P CHECKER, PIN HOLE Sensor Firmware Version - 2P CHECKER, PIN HOLE Sensor Firmware Version
CANCEL Button : Exit	

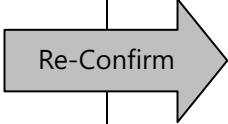
<ul style="list-style-type: none"> <li>● <b>FACTORY-SETTING</b> : Initializing to Factory Setting (Delete All Data and Setsat Default Value)</li> <li>● <b>Notice: Score Type and Elevator Setting will not be initialized against Factory Setting</b></li> </ul>	
<b>LCD DISPLAY (Execution)</b>  <b>FACTORY-SETTING</b> ARE YOU SURE? YES or [ <u>NO</u> ] Execute by moving cursor	<b>LCD DISPLAY (Execution)</b>  <b>FACTORY-SETTING</b> REALLY ? YES or [ <u>NO</u> ] Execute by moving cursor
	

## 4-4. TEST MODE

TEST MODE		
TEST ITEMS	SETTING ITEMS	DESCRIPTIONS
INPUT TEST	[=>]	Enter into the check mode of Input Status
		Display of Input Status of each item at LCD window
		(Button, Coin, Ticket, Sensor... Etc)
FND & LAMP	Operation Test for Lamp, FND, LED When pressing the select button, the test will be carried out step by step	
	<u>"STEP"</u>	<p>LAMP</p> <ul style="list-style-type: none"> <li>▶ Overall On/Off flickering</li> <li>▶ 1P Button Lamp ON</li> <li>▶ 2P Button Lamp ON</li> <li>▶ 1P Ticket Lamp ON</li> <li>▶ 2P Ticket Lamp ON</li> <li>▶ Inside Ceiling Lamp On</li> <li>▶ The middle billboard Lamp On</li> <li>▶ Lamps above speaker on both sides Lights On</li> <li>▶ Lamps above billboard on left side Lights On</li> <li>▶ Lamps above billboard on right side Lights On</li> </ul> <p>Operation Test will be repeated in above sequence</p>
		<p>FND</p> <ul style="list-style-type: none"> <li>▶ Overall On/Off flickering</li> <li>▶ Total Number Counts[0000] ~ [9999]</li> <li>▶ 1P PIN HOLE FND [11], [11], [11],[11], [11], [11]</li> <li>▶ 2P PIN HOLE FND [22], [22], [22], [22], [22],[22]</li> </ul>
		<p>LED</p> <ul style="list-style-type: none"> <li>▶ Overall White On, Offflickering</li> <li>▶ Lights on in sequence of RED ▶ GREEN ▶ BLUE ▶ WHITE</li> <li>▶ LED lights on in white color in individual sequence</li> </ul>
	"ON"	Totally Lights On (For reference, the On-State shall be maintained in other test mode)
	"ON/OFF"	Overall On/Off repetition
	"OFF"	Totally Light Off
	MOT CHECKER	Operation Test of Main Checker Motor ◎ Select the choice with Left, Right Button and press the select button (OR,individual On/Off operation with 1P, 2P shooting button)
"ALL"		1P, 2P Main checker motor operation
"1P"		1P Main checker operation
"2P"		2P Main checker operation
1P, 2P the individual area of Pin Goal In Hole FND shows individual check status PIN HOLE FND : [ 1 ] [ 2 ] [ 3 ] [ ] [ 5 ] [ 6 ] [ 7 ] HOLE NO 1 FND [■□] :Display of encoder sensor status at starting point (0 or 1) [□■] :Display of encoder sensor status at equinoctial point (0 or 1) HOLE NO 2 FND [■■] :Check count of encoder sensor at starting point HOLE NO 3 FND [■■] :Check count of encoder sensor at equinoctial point		

	<p>HOLE NO 5 FND [□□] : Micro Switch Check Count Inside path of Main Checker Hole</p> <p>HOLE NO 6 FND [■■] : Check count of main checker sensor (in case of error, it shows“Er”)</p> <p>HOLE NO 7 FND [■■] : Operation status of Main checker motor (display of ON/OFF)</p> <p>If the sensor of main belt checker (1P, 2P) is checked, it displayed as RED at LED light</p>	
	<p>When it operates in motor test, Set Up LCD screen changes to display of sensor status</p>	
	<p>- TEST MOT CHECKER -</p> <p>1P SEN: 0, 2P SEN: 0</p> <p>1P ENC : 0/0, 0</p> <p>2P ENC : 0/0, 0</p>	<p>1P, 2P Display of Main Checker Sensor Status (0 or 1)</p> <p>1P, 2P Status of Motor Encoder sensor status at Datum point/Equinoctial Point, Check Count at Equinoctial Point</p>
<p>MOT BALL SHOT</p>	<p>Operation test of Ball Elevator</p> <p>◎ Pressthe select button after selecting the choice by Left/RightButton (OR individual On/Off operation with shooting button)</p>	
	<p>“ALL”</p>	<p>1P, 2P Operation of ball elevator (ball shooting)</p>
	<p>“1P”</p>	<p>1P Operation of ball elevator (ball shooting)</p>
	<p>“2P”</p>	<p>2P Operation of ball elevator (ball shooting)</p>
	<p>1P, 2P the individual area of Pin Goal In Hole FND shows individual check status</p> <p>PIN HOLE FND : [ 1 ] [ 2 ] [ 3 ] [ ] [ 5 ] [ 6 ] [ 7 ]</p> <p>HOLE NO 1 FND [□■] : Display of #1 Hole ball sensor check count</p> <p>HOLE NO 2 FND [□■] : Display of #2 Hole ball sensor check count</p> <p>HOLE NO 3 FND [□■] : Display of #3 Hole ball sensor check count</p> <p>★ HOLE NO 5 FND [■□] : Display of #4 Hole ball sensor check count (Since there is no separate FND for Multi Ball Gauge Hole, the check count number is shown at 1<sup>st</sup> place from right at Hole #5 FND)</p> <p>HOLE NO 5 FND [□■] : Display of #5, 1<sup>st</sup> place from left, Hole ball sensor check count</p> <p>HOLE NO 6 FND [□■] : Display of #6 Hole ball sensor check count</p> <p>HOLE NO 7 FND [□■] : Display of #7 Hole ball sensor check count (Each sensor check count is displayed 0~9)</p> <p>◎ Shooting Button Lamp : Upper distribute sensor status is shown by On, Off Lamp</p> <p>◎ Ticket Button Lamp : Encoder sensor status is displayed by On, Off Lamp</p>	
	<p>When it operates in motor test, Set Up LCD screen changes to display of sensor status</p>	
	<p>- TEST MOT CHECKER -</p> <p>1PSEN: 0/0, 2PSEN: 0/0</p> <p>1P: 0, 1,2,3,4,5,6,7</p> <p>2P: 0, 1,2,3,4,5,6,7</p>	<p>1P, 2P Status of Encoder at lower part of Ball Elevator and sensor status at upper part</p> <p>1P, 2P: Display of Checker Sensor Check Count and Check Status of Goal In Hole</p> <p>The sequence of Goal In Hole starts with 1st,2nd,3rd,4th, 5th,6th,7th hole from left.</p>



MOT PIN MOVE	Pin Swing Motor Test ◎ Select the choice by Left/Right button and press Select button (OR, individual On, Off operation by 1P, 2P shooting button)	
	"ALL"	1P, 2P Pin Swing Motor Operation
	"1P"	1P Pin Swing Motor Operation
	"2P"	2P Pin Swing Motor Operation
	1P, 2P the individual area of Pin Goal In Hole FND shows individual check status PIN HOLE FND : [ 1 ] [ 2 ] [ 3 ] [ ] [ 5 ] [ 6 ] [ 7 ] HOLE NO 1 FND [ □ ■ ] : Display of Encoder Sensor Status(0 or 1) HOLE NO 2 FND [ □ □ ] : HOLE NO 3 FND [ ■ ■ ] : Display of Encoder Sensor Check Status Count (to be increased by sensor check 1 count) HOLE NO 5 FND [ □ □ ] : HOLE NO 6 FND [ □ □ ] : HOLE NO 7 FND [ ■ ■ ] : Display of Pin swing motor operation (display of On/Off)	
	When it operates in motor test, Set Up LCD screen changes to display of sensor status	
	- TEST MOT PIN MOVE - 1P ENC : 0, 0 2P ENC : 0, 0	1P, 2P Motor Encoder Sensor Status, Check Count at Equinoctial Point
CARD BELT	Card Belt Operation Test ◎ Select the type with Left, RightButton and press select button ◎ 1P, 2P Service Button : Test for distributing one cardout (card-distributing at game) Automatic card distributing from card dispenser in time for the interval of card distributing ◎ 1P, 2P Ticket Button : Operation of card belt drop sensor, Power On, Off	
	"ALL"	1P, 2P Operation of card belt
	"1P"	1P Operation of card belt
	"2P"	2P Operation of card belt
	1P, 2P the individual area of Pin Goal In Hole FND shows individual check status PIN HOLE FND : [ 1 ] [ 2 ] [ 3 ] [ ] [ 5 ] [ 6 ] [ 7 ] HOLE NO 1 FND [ □ ■ ] : Display of Encoder Sensor Status (0 or 1) HOLE NO 2 FND [ □ □ ] : HOLE NO 3 FND [ ■ ■ ] : Display of Encoder Sensor Check Status HOLE NO 5 FND [ □ ■ ] : Display of Card belt drop sensor status (0 or 1) HOLE NO 6 FND [ ■ ■ ] : Display of Card belt drop sensor check status count HOLE NO 7 FND [ ■ ■ ] : Display of Card belt operation status (Display On or Off)	
CARD OUT (Card Dispenser)	Card Dispenser Test ◎ Select the type with Left, RightButton and press select button (OR with shooting button of 1P, 2P, individual On, Off operation is possible)	
	"ALL"	1P, 2P Distributing one card from card dispenser
	"1P"	1P Distributing one card from card distributor
	"2P"	2P Distributing one card from card distributor

	<p>1P, 2P the individual area of Pin Goal In Hole FND shows individual check status PIN HOLE FND : [ 1 ] [ 2 ] [ 3 ] [ ] [ 5 ] [ 6 ] [ 7 ]</p> <p>HOLE NO 1 FND [□■] : Display of card dispenser sensor status (0 or 1) HOLE NO 2 FND [□□] : HOLE NO 3 FND [□□] : HOLE NO 5 FND [□□] : HOLE NO 6 FND [□■] : Display of re-try number of card dispenser (in case it becomes 03, it's an error) HOLE NO 7 FND [■■] : Display of card dispenser operation status (display of On/Off), In case error occurs, it show "Er"</p>	
COIN	<p>Coin Operation Test</p> <p>◎ When pressing Select Button, both 1P and 2P On, Off operates</p> <p>◎ With shooting button of IP/2P, individual On, Off operates</p>	
	"ON", "OFF"	Coin selector operates On, Off
	<p>1P, 2P the individual area of Pin Goal In Hole FND shows individual check status PIN HOLE FND : [ 1 ] [ 2 ] [ 3 ] [ ] [ 5 ] [ 6 ] [ 7 ]</p> <p>HOLE NO 1 FND [□■] : Display of bill collector sensor status (0 or 1) HOLE NO 2 FND [■■] : Display of bill collector sensor check count (00 ~ 99 count repeats)</p> <p>HOLE NO 3 FND [□□] : HOLE NO 5 FND [□□] : HOLE NO 6 FND [□□] : HOLE NO 7 FND [■■] : Display of bill collector sensor operation status (On, Off) and Error "Er"</p>	
BILL	<p>Bill Collector operation test</p> <p>◎ When pressing Select Button, both 1P and 2P On, Off operates</p> <p>◎ With shooting button of IP/2P, individual On, Off operates</p>	
	"ON", "OFF"	Bill Collector Operation On, Off
	<p>1P, 2P the individual area of Pin Goal In Hole FND shows individual check status PIN HOLE FND : [ 1 ] [ 2 ] [ 3 ] [ ] [ 5 ] [ 6 ] [ 7 ]</p> <p>HOLE NO 1 FND [□■] : Display of bill collector sensor status (0 or 1) HOLE NO 2 FND [■■] : Display of bill collector sensor check count (00 ~ 99 count repeats)</p> <p>HOLE NO 3 FND [□□] : HOLE NO 5 FND [□□] : HOLE NO 6 FND [□□] : HOLE NO 7 FND [■■] : Display of bill collector sensor operation status (On, Off) and Error "Er"</p>	
TICKET	<p>Ticket Dispenser operation test</p> <p>◎ Select the type with Left, RightButton and press select button</p> <p>◎ With ticket-release button of IP/2P, individual ticket dispenser works (release of 3 tickets)</p>	
	"ALL"	Ticket dispenser operation test of both 1P and 2P (Release of 3 tickets basically)

	"1P", "2P",	Individual ticket dispenser operation for 1P and 2P (Release of 3 tickets)
	<p>1P, 2P the individual area of Pin Goal In Hole FND shows individual check status PIN HOLE FND : [ 1 ] [ 2 ] [ 3 ] [ ] [ 5 ] [ 6 ] [ 7 ]</p> <p>HOLE NO 1 FND [ □ ■ ] : Display of ticket dispenser sensor status (0 or 1) HOLE NO 2 FND [ ■ ■ ] : Display of ticket dispenser sensor check count (00 ~ 99 count repeats)</p> <p>HOLE NO 3 FND [ □ □ ] : HOLE NO 5 FND [ □ □ ] : HOLE NO 6 FND [ □ □ ] : HOLE NO 7 FND [ ■ ■ ] : Display of ticket dispenser operation status (On, Off) And display of error "Er"</p>	
COUNTER	<p>COUNTER TEST</p> <ul style="list-style-type: none"> <li>◎ Select the type by Left, Right button and press select button and then it increases by one in sequence of 1P ► 2P</li> <li>◎ 1P, 2P press each Service Button and Coin In of each player increases</li> <li>◎ 1P, 2P press each Ticket Button and Ticket Out Counter of each player increases</li> </ul>	
	"COIN"	Operation of Coin Counter for both 1P and 2P It increases by 1 in sequence from 1P to 2P
	"TICKET"	Operation of Ticket Counter for both 1P and 2P It increases by 1 in sequence from 1P to 2P
SOUND	<p>SOUND TEST</p> <ul style="list-style-type: none"> <li>◎ Select the type by Left, Right button and then test by select button (Play, Stop)</li> </ul>	
	"OFF"	Stop sound play
	"CH"	Test individual speaker (1P Left, 2P Right)
	"PLAY"	Play of total sound Press Shoot or Service button and play next list
SCREEN	<p>Video Monitor Screen Test</p> <ul style="list-style-type: none"> <li>◎ Select the type by Left, Right button and test each item by select button in sequence of each item</li> </ul>	
	"OFF"	Monitor Screen Waiting Status
	"GRID"	Monitor Screen Grid Patten Test
	"COLOR"	Monitor Screen Color Test
	"RED"	Monitor Screen Paint in Red
	"GREEN"	Monitor Screen Paint in Green
	"BLUE"	Monitor Screen Paint in Blue
"WHITE"	Monitor Screen Paint in White	
EXIT	Exit to Operating Options	

## 4-5. FIELD TEST

### ● FIELD TEST

Exclusive Check Mode for Ball Shooting and Main Checker Sensor of Ball Elevator and Sensor Status of Pin Goal In

It changes to the information of Field Test when moving up and down the cursor at Set Up stage and pressing Down Button at Exit Item

Information about Field Test will be deleted by “Clear”, “Data Clear” or “Factory Set”

When pressing Start Button while test is not being performed, ball goes off automatically with the checker in a state of stop.

When testing after adjusting the position of main checker hole sensor in order for the balls go in, compare the status of check counter for checker and back up micro switch

When pressing the Ticket Button while test is not being performed, one ball goes off.

Use this function just in case of testing the ball shooting counter of ball elevator and sensor status exactly.

Display of LCD	Description
<b>SHOT COUNT</b> <b>500</b>	Number of balls to shoot for testing purpose FULL : Shooting without limitation on number of balls 500 : Shooting 500 balls (Changes by 100 from 100 to 100,000)
<b>PLAYER</b> "ALL"	Player to test ALL : 1P, 2P All Players 1P : 1 Player 2P : 2 Players
<b>SPEED</b> <b>0.5</b>	Time-Setting for ball shooting interval 0.3 : at an interval of 0.3 second, 0.5 : at an interval of 0.5 second, 1.0 : at an interval of 1.3 second, 1.5 : at an interval of 1.5 second, 2.0 : at an interval of 2.0 second
<b>TEST</b> <b>OFF</b>	Start Test OFF : State of stopping test ON : State of performing test <b>For reference, when pressing Select Button, the test shall be stopped immediately regardless of cursor position.</b> When pressing Select Button after moving the cursor to Test, Field Test shall be started and LCD monitor moves to the ball shooting and Sensor Check Count
<b>CLEAR</b>	Delete Test Data While “Yes or No” choice shows up in monitor, select “Yes” by Left or Right button and press the Select Button to delete Field Test Data
<b>EXIT</b>	Exit to previous menu (Exit to previous menu is also possible by pressing Cancel button) When pressing Cancel Button, it stops performing test and exit to previous menu immediately

Following items are contents to be displayed at test information monitor after moving to next screen by pressing Down Button at Exit Menu. When pressing Up Button again, the cursor moves to Menu Items

<p><b>TOTAL BALL &amp; SENSOR</b>          ( 500) 1P      2P  <b>BALL :</b>    0,      0  <b>SEN :</b>      0,      0</p>	<p>Check total number of ball shooting and total count of sensor check state in Field Test          (500: check current setting of ball shooting number) and display of items to divide 1P and 2P          Total ball shooting count          Total sensor check count</p>
<p><b>SENSOR CHECK COUNT</b>   <b>CHK~:</b>    0,      0  <b>BS/W:</b>    0,      0  <b>PIN :</b>      0,      0</p>	<p>Reference only for the comparison of main checker sensor and checker back up micro switch sensor count AND count for the number of checking checker sensor and total count for goal in hole           Ex) When number of ball shooting is 100 and total number of sensor check is 100, if the number of main checker is 15 and goal in hole is 85, total sensor count is 100.          Main checker sensor count          Micro Switch check count for main checker back up          Total number of sensor check count from pin goal in hole #1 to #7</p>
<p><b>PIN HOLE SENSOR</b>  <b>PIN1:</b>    0,      0  <b>PIN2:</b>    0,      0  <b>PIN3:</b>    0,      0</p>	<p>Check Sensor Check Status of each pin hole          #1 Goal In Hole Sensor Check Count (a hole          #2 Goal In Hole Sensor Check Count          #3 Goal In Hole Sensor Check Count</p>
<p><b>PIN4:</b>    0,      0  <b>PIN5:</b>    0,      0  <b>PIN6:</b>    0,      0  <b>PIN7:</b>    0,      0</p>	<p>#4 Goal In Hole Sensor Check Count (a hole right in the center)          #5 Goal In Hole Sensor Check Count          #6 Goal In Hole Sensor Check Count          #7 Goal In Hole Sensor Check Count (a hole at the very right)</p>

## 4-6. ERROR CODE

ERROR CODE	TYPE OF ERROR	CONTENTS	CHECK ITEMS
E.02	System	Setup Saving Data Error	<ol style="list-style-type: none"> <li>1. check or save setup condition</li> <li>2. Factory Setting</li> <li>3. Check power ON or OFF</li> <li>4. Replace Main Board when error occurs continuously</li> </ol>
E.03		Game Saving Data Error	<ol style="list-style-type: none"> <li>1. Clear Data at Set Up Clear Mode</li> <li>2. Check the power (ON/OFF)</li> <li>3. Replace Main Board when error occurs continuously</li> </ol>
E.11	Coin Selector	Continuous existence of player coin sensor signal	Check input of defective coin sensor
E.13	Bill Collector	Continuous existence of bill collector sensor signal	Check sensor input of bill collector
E.21	MK(PC) Serial Communication	<p>No communication between Video and MK (PC)</p> <p><b>Video display can not be controlled in communication error. So it needs to be taken care of separately and main board error is to be shown at FND</b></p>	<ol style="list-style-type: none"> <li>1. Check wiring connection</li> <li>2. Check MK (PC) Operation (normal booting)</li> <li>3. Check mainboard communication</li> </ol>
E.31	Main Checker Motor	No signal from equinoctial encoder	<ol style="list-style-type: none"> <li>1. Check operation status of motor</li> <li>2. Check encoder sensor input status</li> </ol>
E.35		Checker sensor problem (Existence of continuous signal)	<ol style="list-style-type: none"> <li>1. Check wiring connection</li> <li>2. Check the sensor input status</li> </ol>
E.41	Card Belt Distribute Motor	No encoder signal	<ol style="list-style-type: none"> <li>1. Check operation status of motor</li> <li>2. Check encoder sensor input status</li> </ol>
E.43		Continuous existence of card drop sensor signal	<ol style="list-style-type: none"> <li>1. Check the operation status of motor</li> <li>2. Check drop sensor operation status</li> </ol>
		No card drop sensor signal	<ol style="list-style-type: none"> <li>3. Check card-jam in card belt</li> <li>4. Check the direction of motor rotation</li> </ol>

\* When "E.02", "E.03", "E.21" error occurs, game completely stops. In case of other errors, however, only plays with those errors stop.

E.51	Pin Swing Motor	No signal from pin swing motor encoder	1. Check operation status of motor 2. Check encoder sensor input status
E.61	Ball Shooting Elevator	Occurrence of problem of Elevator Jam	1. Check ball jamming 2. Check encoder sensor
E.62		Problem of upper ball shooting sensor (No signal)	1. Check existence of ball 2. Check status of ball
E.71	Pin Hole Goal In Sensor	Continuous existence of sensor signal at pin goal in hole #1	1. Check status of pin goal in hole sensor #1
E.72		Continuous existence of sensor signal at pin goal in hole #2	1. Check status of pin goal in hole sensor #2
E.73		Continuous existence of sensor signal at pin goal in hole #3	1. Check status of pin goal in hole sensor #3
E.74		Continuous existence of sensor signal at pin goal in hole #4	1. Check status of pin goal in hole sensor #4
E.75		Continuous existence of sensor signal at pin goal in hole #5	1. Check status of pin goal in hole sensor #5
E.76		Continuous existence of sensor signal at pin goal in hole #6	1. Check status of pin goal in hole sensor #6
E.77		Continuous existence of sensor signal at pin goal in hole #7	1. Check status of pin goal in hole sensor #7
E.78		No signal from main checker or pin goal in hole sensor	1. Check ball jamming 2. Check status of pin goal in sensor
E.81	Card Dispenser	No card or non-operation of card distributing device	1. Check existence of card 2. Check card distributing device
HELP Display at video ticket window	Ticket Error	No Tickets	1. Check existence of ticket 2. Check operation of ticket motor 3. Check ticket distributing sensor
<p>※ Normally Error Code will be displayed at SET UP LCD, Player's monitor where error occurred and Pin Hole Score FND. Error message and Error Code Number will be displayed.</p> <p>※ Normally MK communication error will be displayed at SETUP LCD and PIN HILE SCORE FND As an exceptional handling apart from this, Error Message will be shown on the screen when there is no communication code within 1 mininuteby MK itself</p>			



## 4-7. ERROR CODE DETECTION METHOD

ERROR CODE	ERROR TYPE	CONTENTS	ERROR DETECTION CONDITION
E.02	System	Problem of Set Up Data Saving	Check setup-related back up memory at main board after power on
E.03		Problem of Game Data Saving	Check game-related back up memory at main board after power on
E.11	Coin Selector	Continuous existence of player coin sensor signal	Continuous signal for more than two seconds while INHIBT is ON
E.13	Bill Collector	Continuous existence of player bill collector sensor signal	Existence of signal for more than two seconds
E.21	MK(PC) Serial Communication	No communication between Video presentation and MK (PC)  <b>Video display can not be controlled in communication error. So it needs to be taken care of separately and main board error is to be shown at FND</b>	1. Before MK Booting It's an error if there is no signal for one minute Booting 2. After MK Booting (completion of main booting) It's an error if there is no signal for 30 seconds (Processing of signal 10 times at an interval of 3 seconds)
E.31	Main Checker Motor	No signal from equinoctial encoder	No signal for two seconds
E.35		Checker sensor problem (Existence of continuous signal)	Continuous existence of signal for more than three seconds
E.41	Card Belt Distributing Motor	No encoder signal	No signal for two seconds
E.43		Continuous existence of card drop sensor signal	Continuous existence of signal for more than three seconds
E.44		No card drop sensor signal	No card drop sensor signal while five cards are distributed
E.51	Pin Swing Motor	No encoder signal from pin swing motor	No signal for more than two seconds

<b>E.61</b>	<b>Ball Shooting Elevator</b>	Problem of Elevator Jamming	In case no encoder signal for over twoseconds, try reverse rotation and then try forward rotation for total 4 times
<b>E.62</b>		Problem of upper ball shooting sensor (No signal)	No distribute sensor signal while ball elevator tries 5 times at an interval of 3 seconds
<b>E.71</b>	<b>Pin Goal In Hole Sensor</b>	Continuous existence of sensor signal at pin goal in hole #1	Continuous Sensor Signal for more than
<b>E.72</b>		Continuous existence of sensor signal at pin goal in hole #2	
<b>E.73</b>		Continuous existence of sensor signal at pin goal in hole #3	
<b>E.74</b>		Continuous existence of sensor signal at pin goal in hole #4	
<b>E.75</b>		Continuous existence of sensor signal at pin goal in hole #5	
<b>E.76</b>		Continuous existence of sensor signal at pin goal in hole #6	
<b>E.77</b>		Continuous existence of sensor signal at pin goal in hole #7	
<b>E.78</b>		No signal from main checker or pin goal in hole sensor	If there is no main checker or goal in hole sensor signal for 15 seconds after shooting 10 balls
<b>E.81</b>	<b>Card Dispenser</b>	No Card or Card dispensing device does not work	There is no sensor signal total 3 timesduring card distributing operation

# 5. TROUBLESHOOTING

\* General check up : Check the supply voltage and wiring connection properly  
 \* "NO" : Means faulty of the check up result.

## 5-1. SERIAL COMMUNICATION ERROR [E.21] - IN CASE OF POOR COMMUNICATION BETWEEN MAIN PCB AND MK (PC)

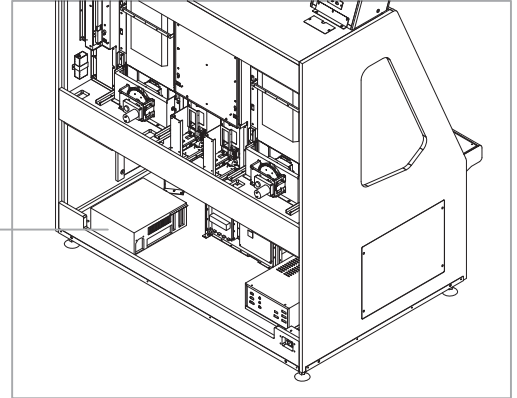

SERIAL COMMUNICATION ERROR [E.21]

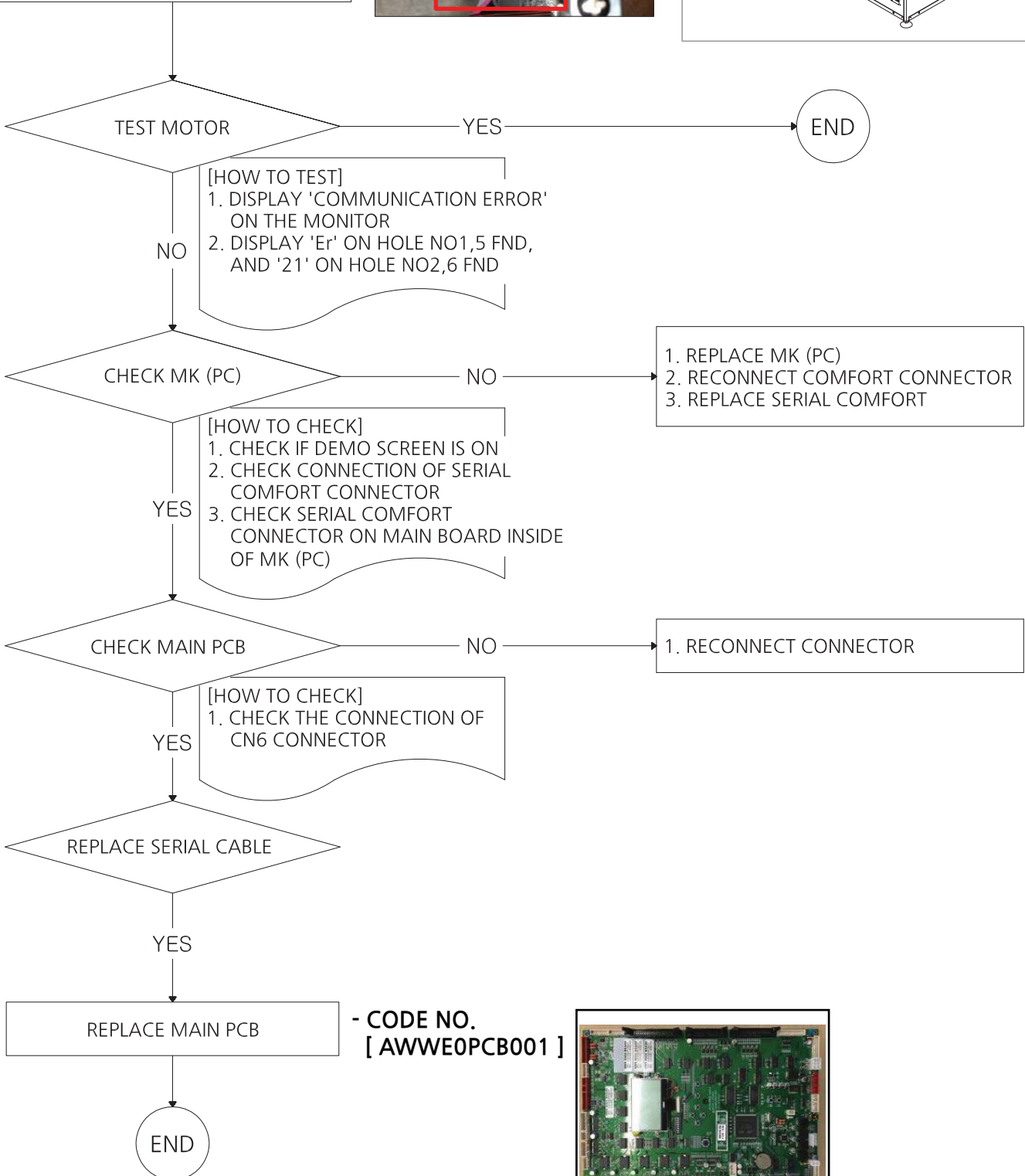

- CODE NO.  
 [ AWWWE0PCB001 ]

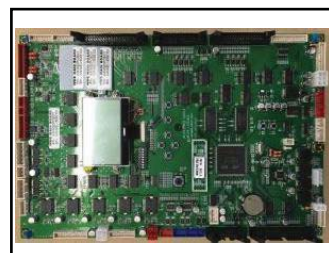

- \* General check up : Check the supply voltage and wiring connection properly
- \* "NO" : Means faulty of the check up result.

## 5-2. MAIN CHECKER MOTOR ERROR [E.31] - IN CASE THE MOTOR IS PROBLEM

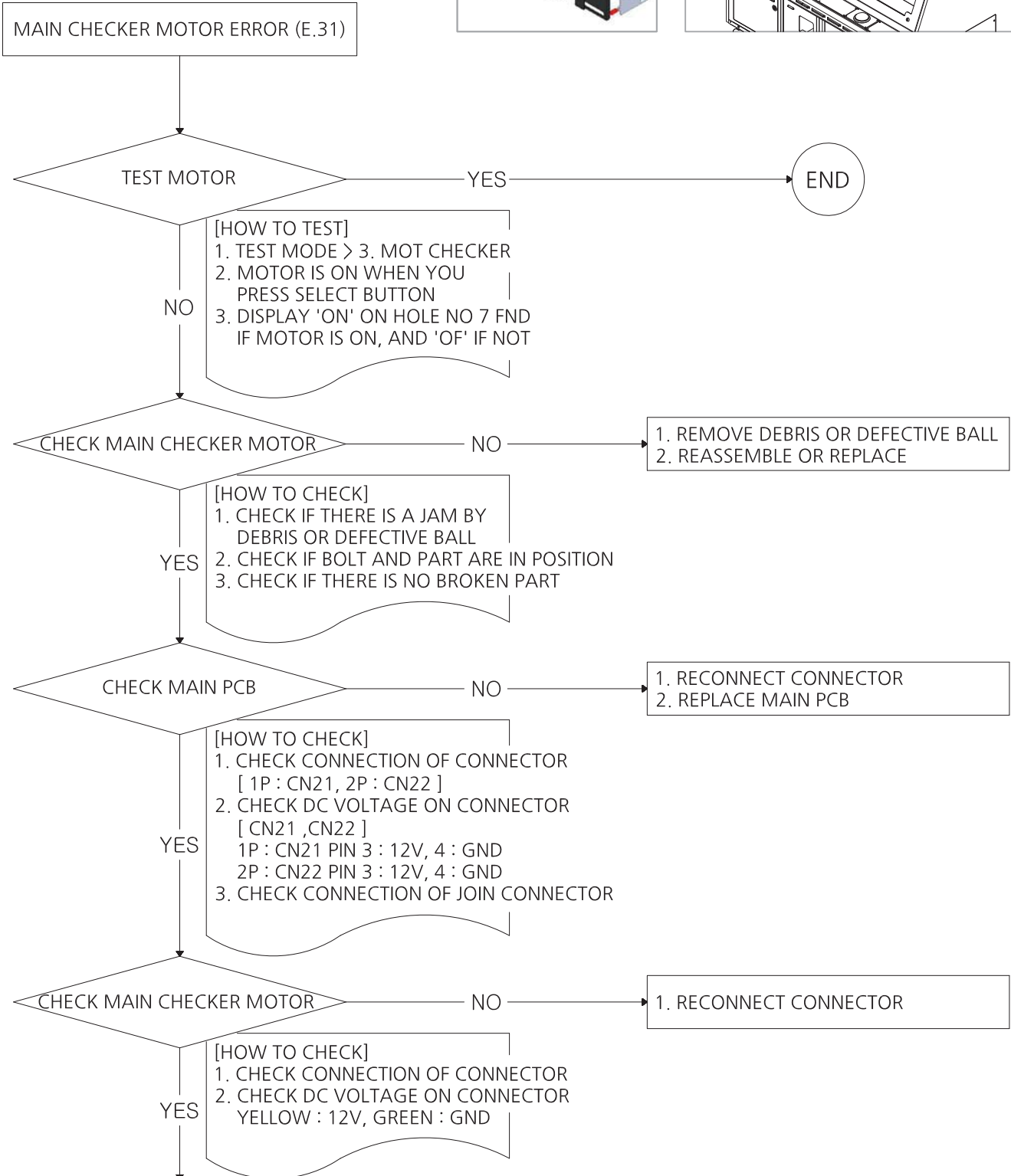
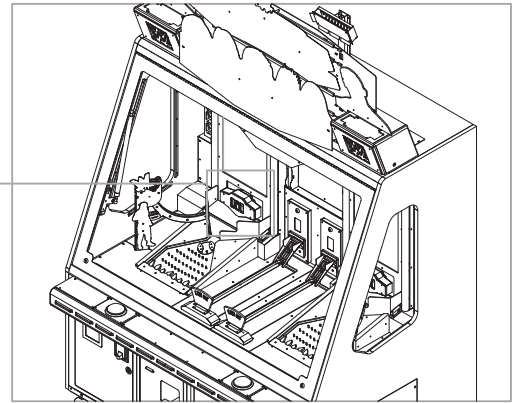
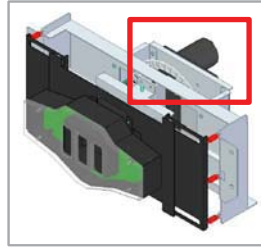

REPLACE MAIN CHECKER MOTOR

NO

REPLACE MAIN PCB

END

- CODE NO.  
[ MZZZ0MOT141 ]

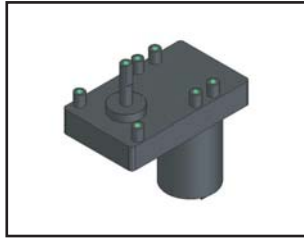

- CODE NO.  
[ AWWEOPCB001 ]



- \* General check up : Check the supply voltage and wiring connection properly
- \* "NO" : Means faulty of the check up result.

## 5-3. MAIN CHECKER MOTOR ERROR [E.31]

### - NO SIGNAL ON ENCODER

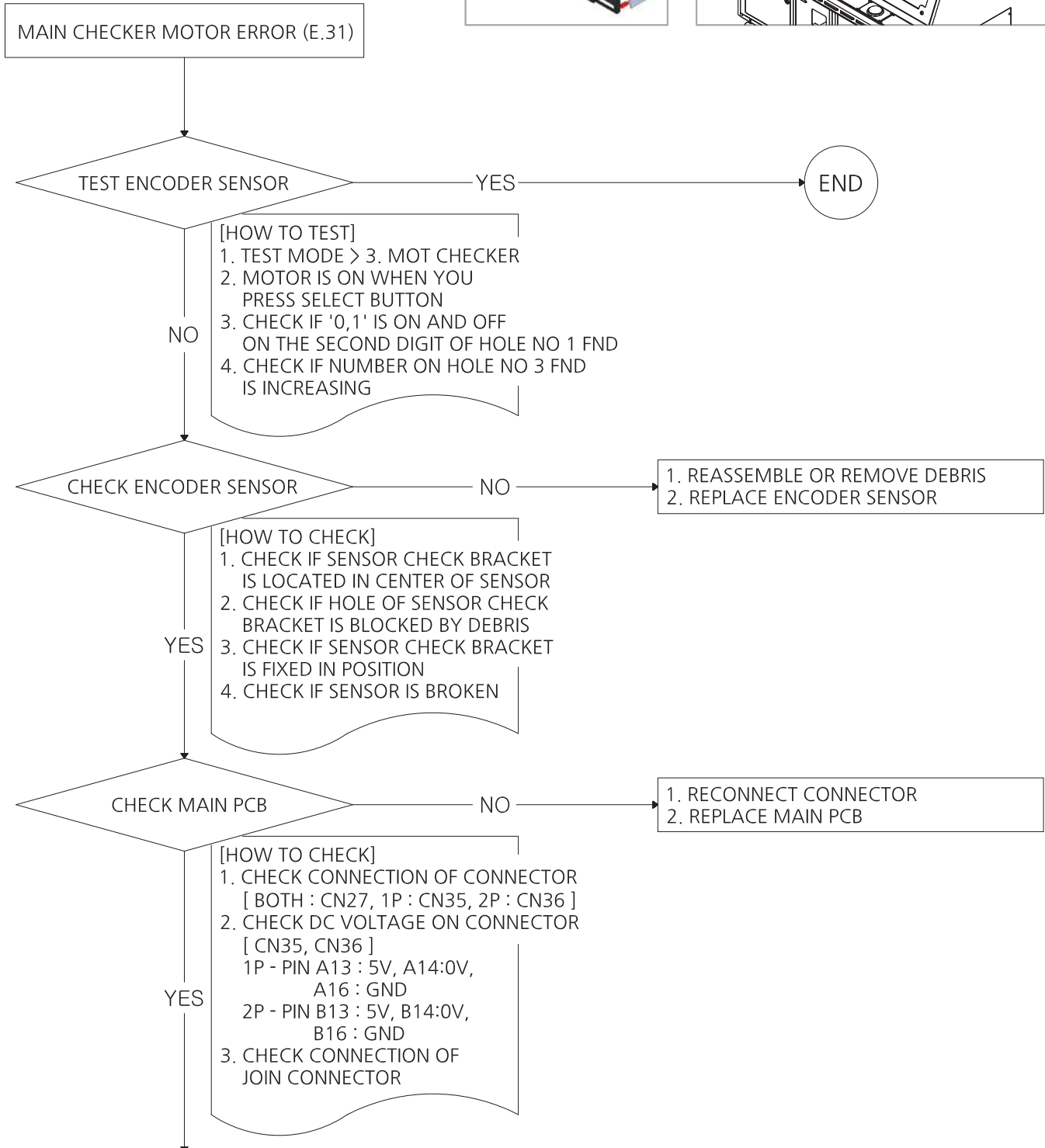
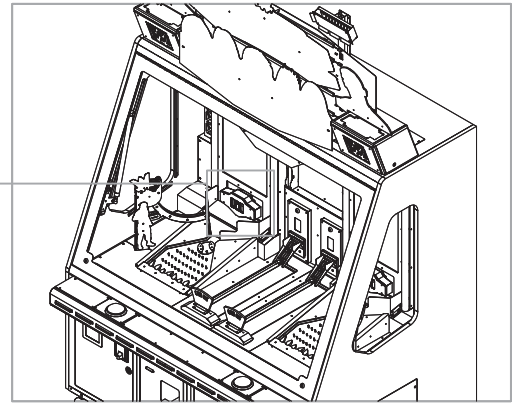
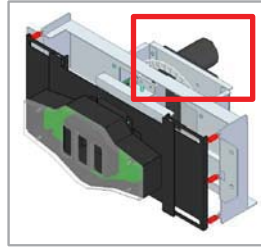

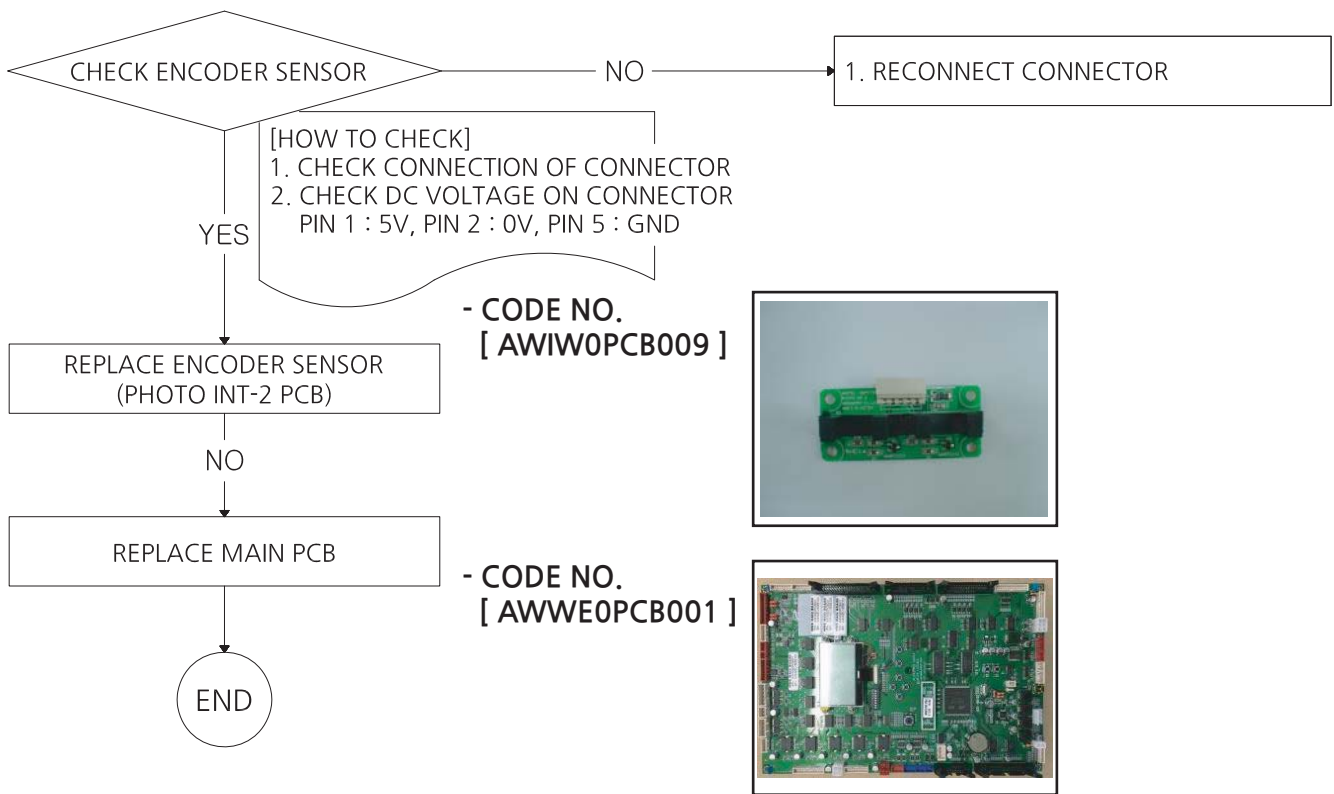



\* General check up : Check the supply voltage and wiring connection properly  
 \* "NO" : Means faulty of the check up result.

## 5-4. MAIN CHECKER SENSOR ERROR [E.35] (BONUS TARGET SENSOR PCB)

- SIGNAL OF CHECKER SENSOR KEEPS ON

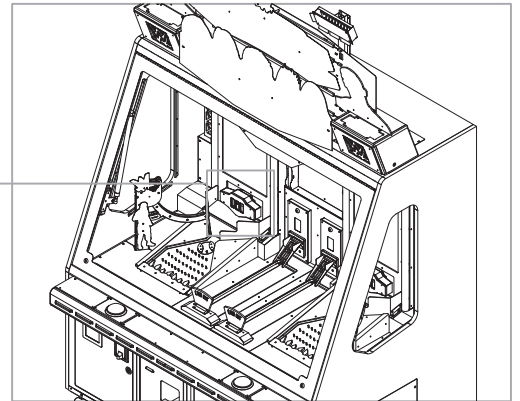
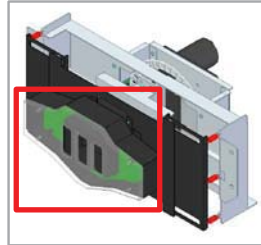

MAIN CHECKER SENSOR  
 (BONUS TARGET SENSOR PCB) ERROR [E.35]

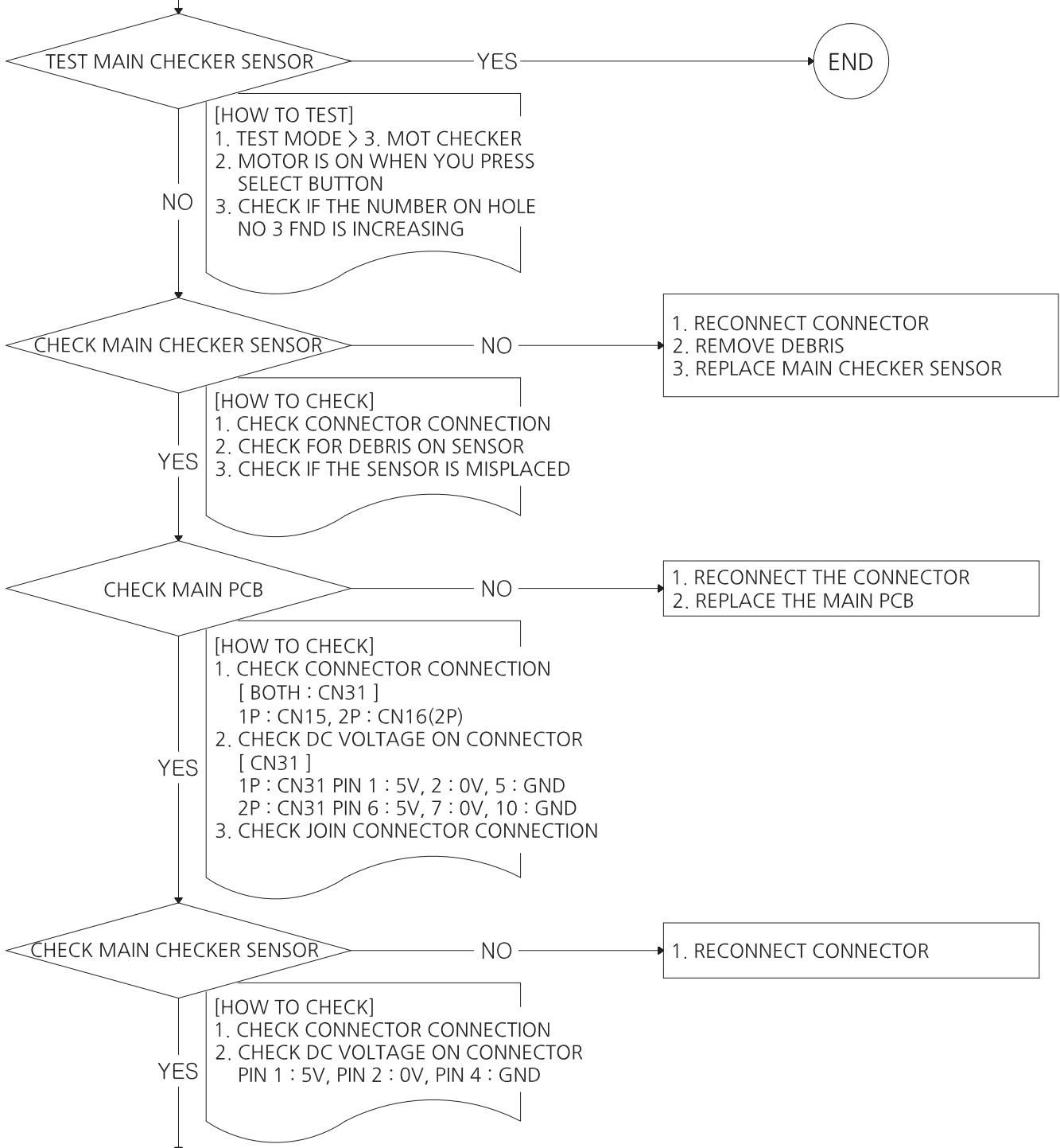

REPLACE MAIN CHECKER SENSOR  
(BONUS TARGET SENSOR PCB)

NO

REPLACE MAIN PCB

END

- CODE NO.  
[ AWWEOPCB005 ]

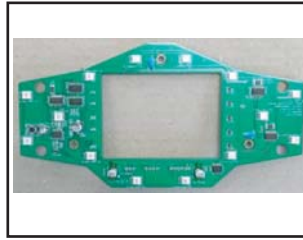

- CODE NO.  
[ AWWEOPCB001 ]



\* General check up : Check the supply voltage and wiring connection properly  
 \* "NO" : Means faulty of the check up result.

## 5-5. CARD BELT MOTOR ERROR [E.41] - IN CASE THE CARD BELT MOTOR IS PROBLEM

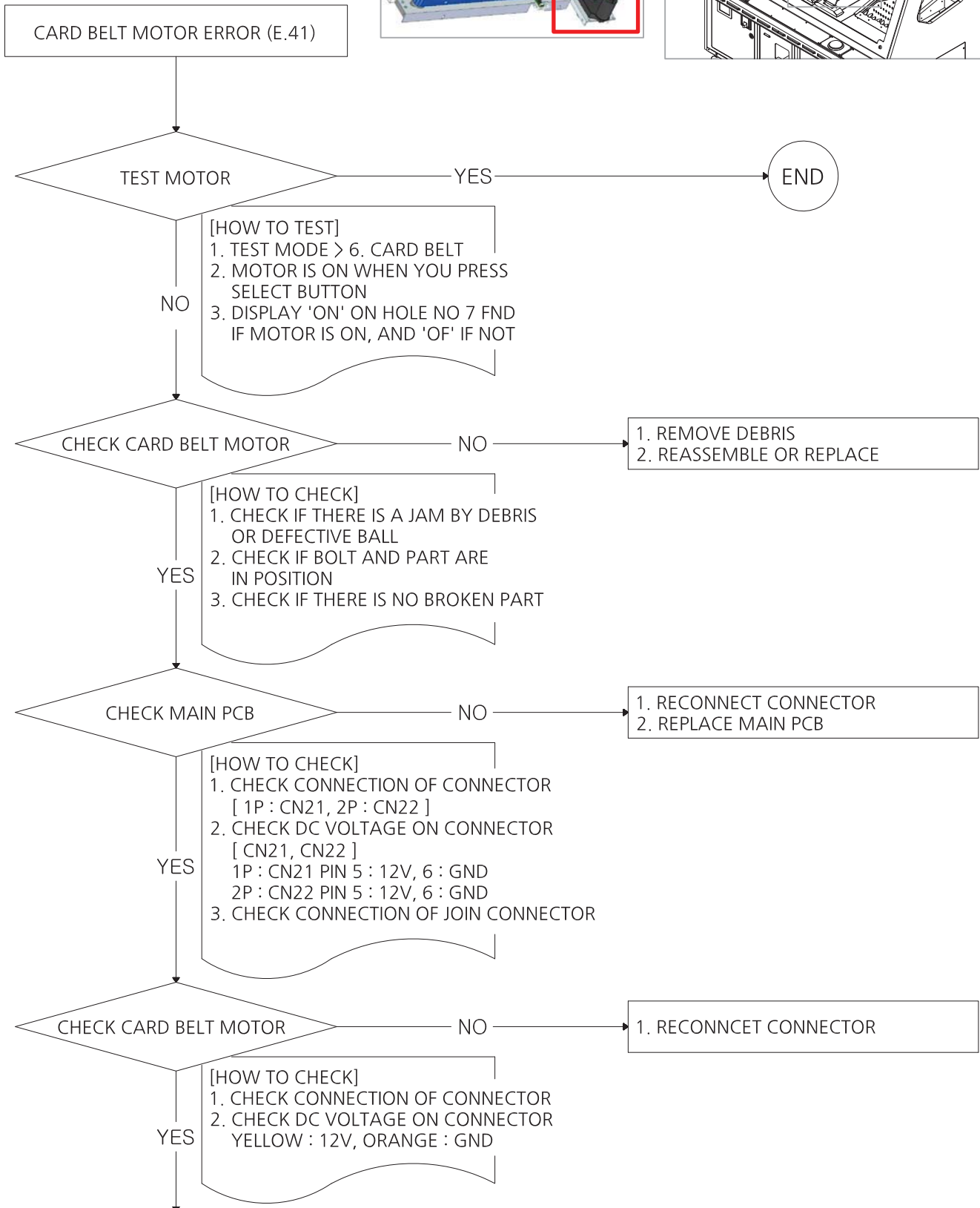
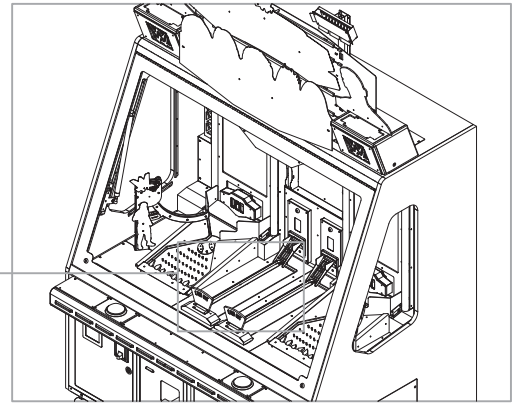
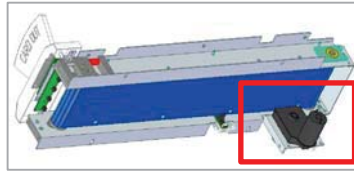

REPLACE MOTOR

NO

REPLACE MAIN PCB

END

- CODE NO.  
[ MZZZ0MOT115 ]



- CODE NO.  
[ AWWEOPCB001 ]

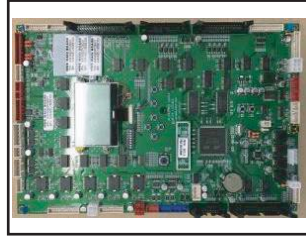

\* General check up : Check the supply voltage and wiring connection properly  
 \* "NO" : Means faulty of the check up result.

## 5-6. CARD BELT MOTOR ERROR [E.41] - NO SIGNAL ON ENCODER

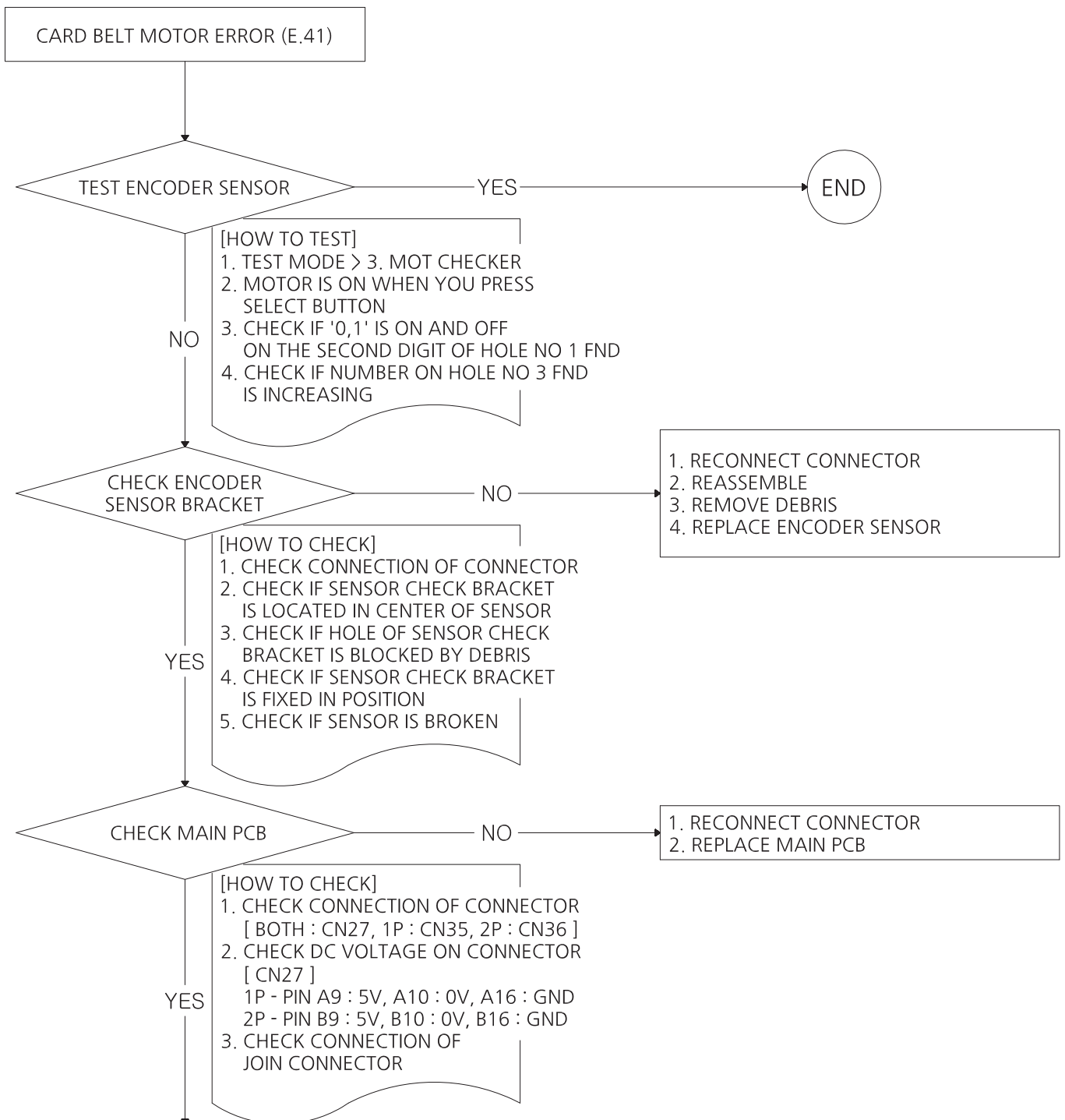
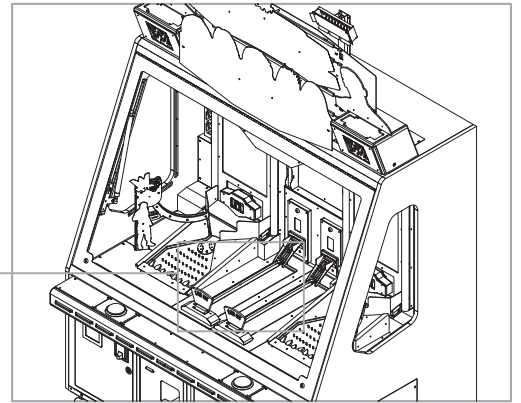
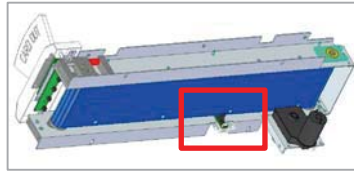

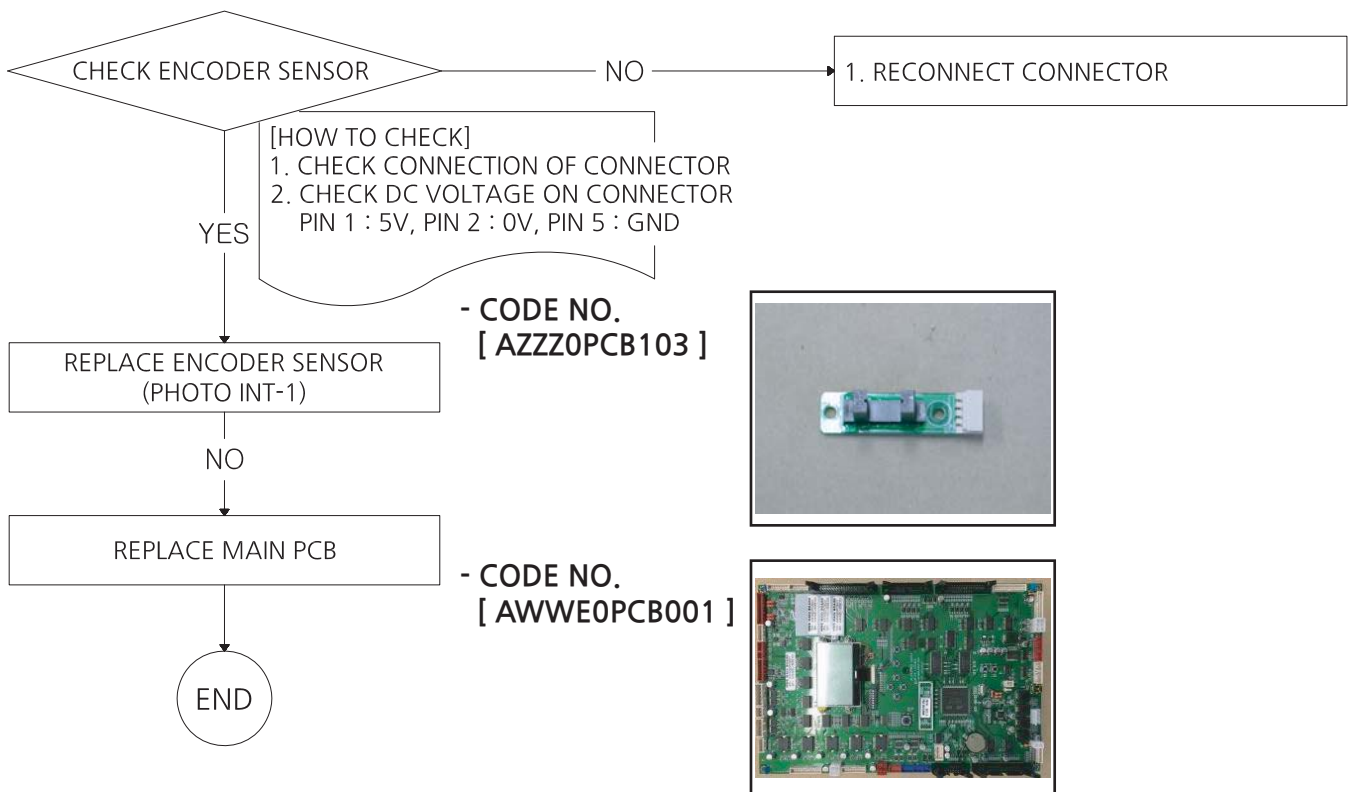

\* General check up : Check the supply voltage and wiring connection properly  
 \* "NO" : Means faulty of the check up result.

## 5-7. CARD DROP SENSOR [E.43, E.44] - SIGNAL KEEPS ON OR NO SIGNAL

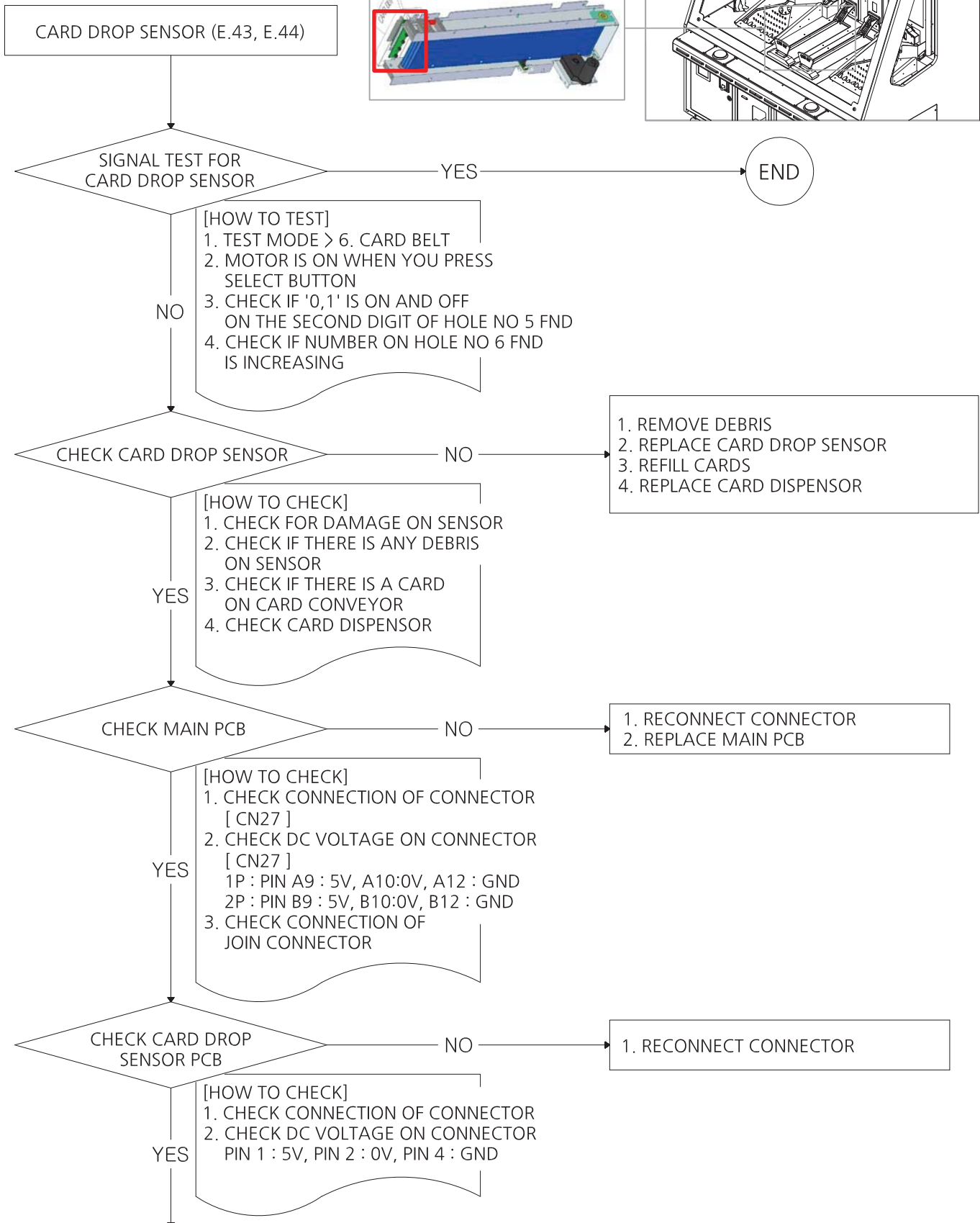
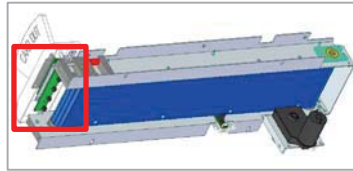
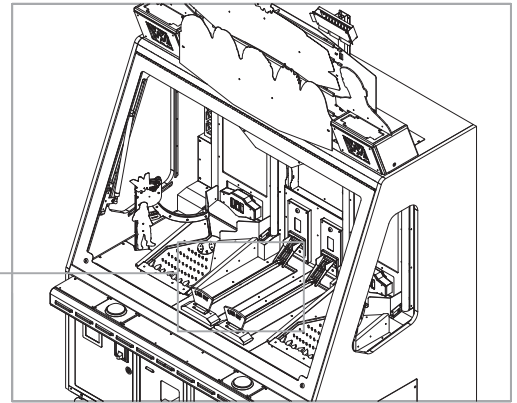



REPLACE CARD DROP SENSOR

NO

REPLACE MAIN PCB

END

- CODE NO.  
[ ADM30PCB003 ]

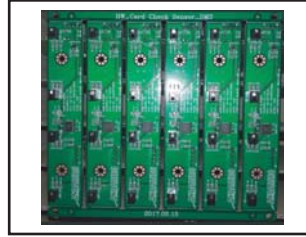

- CODE NO.  
[ AWE0PCB001 ]



- \* General check up : Check the supply voltage and wiring connection properly
- \* "NO" : Means faulty of the check up result.

## 5-8. PIN SWING MOTOR ERROR [E.51] - IN CASE THE MOTOR IS PROBLEM

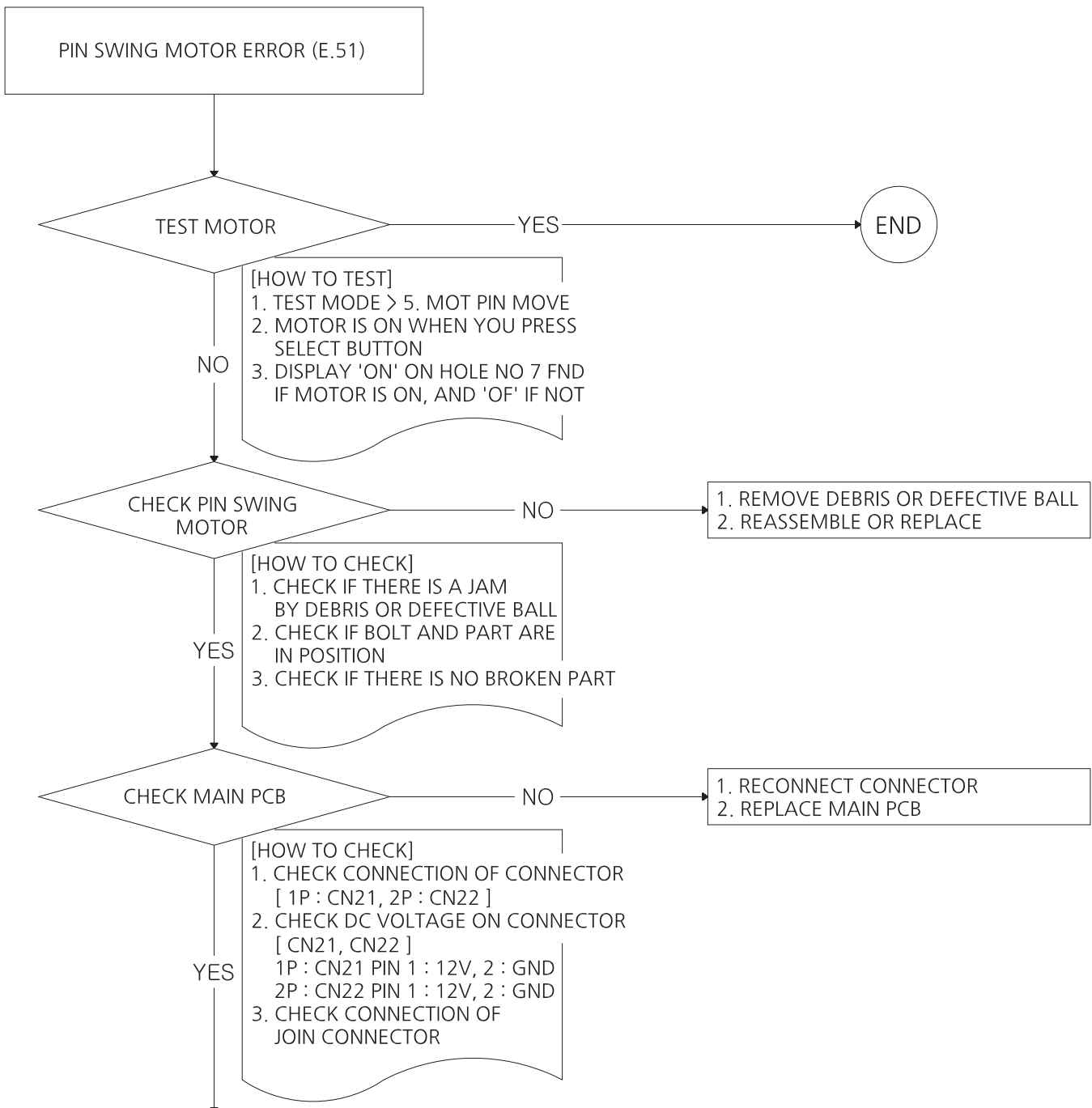
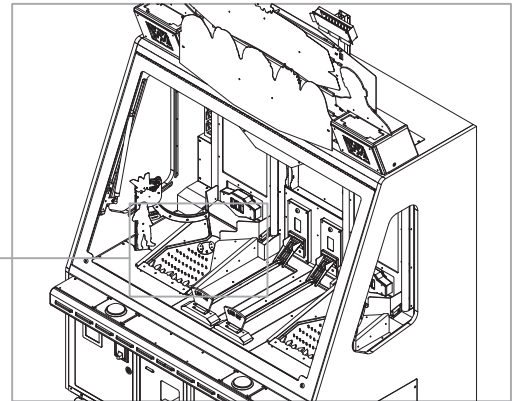
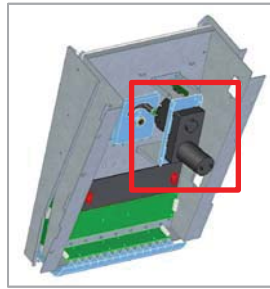

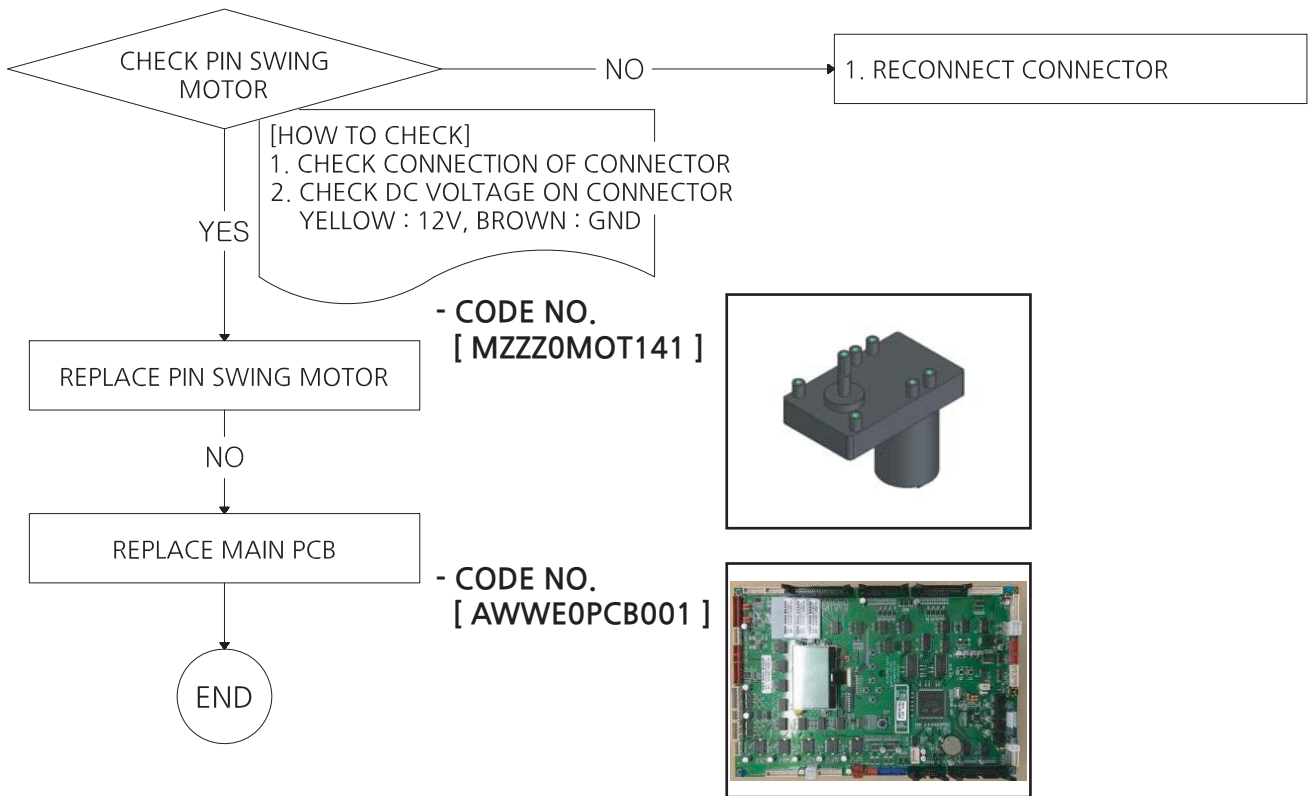

\* General check up : Check the supply voltage and wiring connection properly  
 \* "NO" : Means faulty of the check up result.

## 5-9. PIN SWING MOTOR ERROR [E.51] - NO SIGNAL ON ENCODER

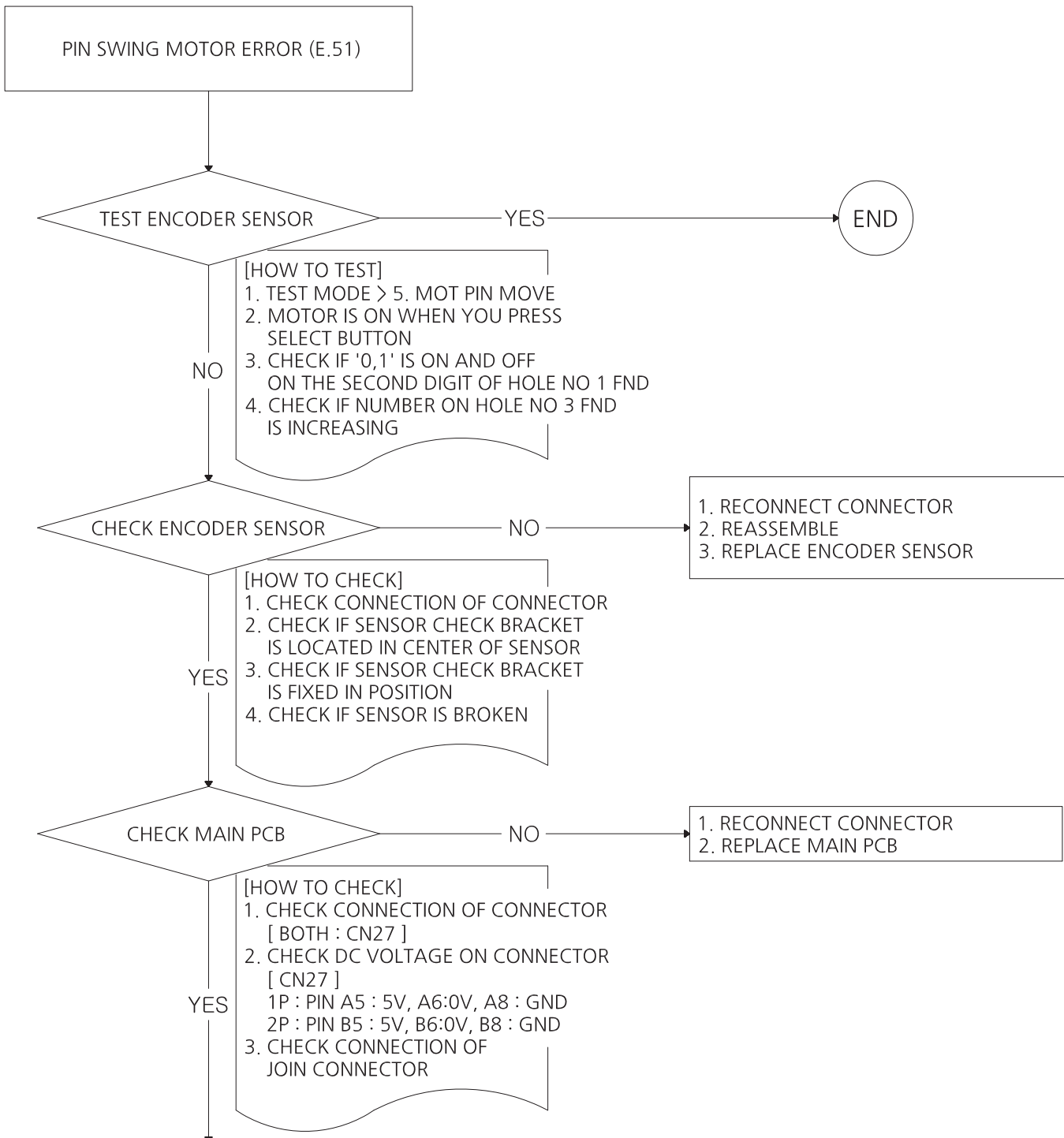
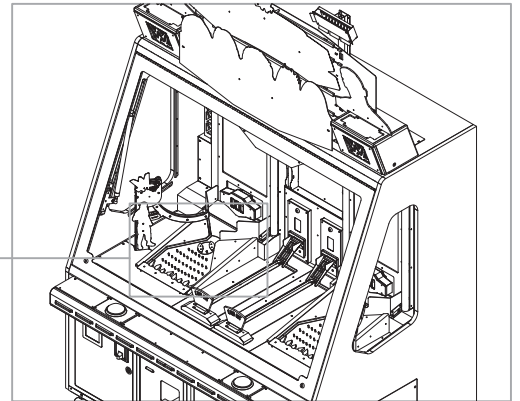
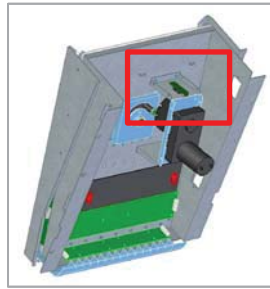

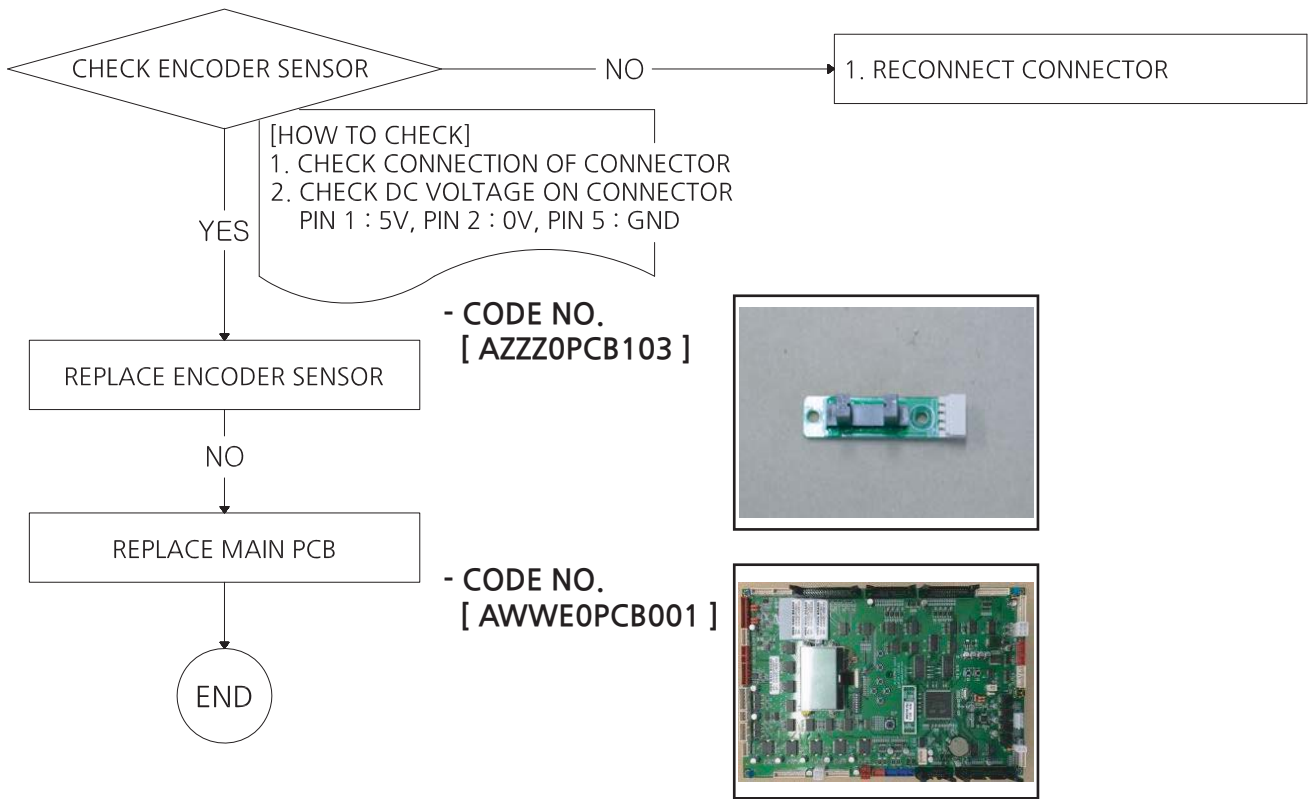

\* General check up : Check the supply voltage and wiring connection properly  
 \* "NO" : Means faulty of the check up result.

## 5-10. PIN GOAL-IN HOLE SENSOR ERROR [E.71~77]

- IN CASE THE SIGNAL KEEPS ON

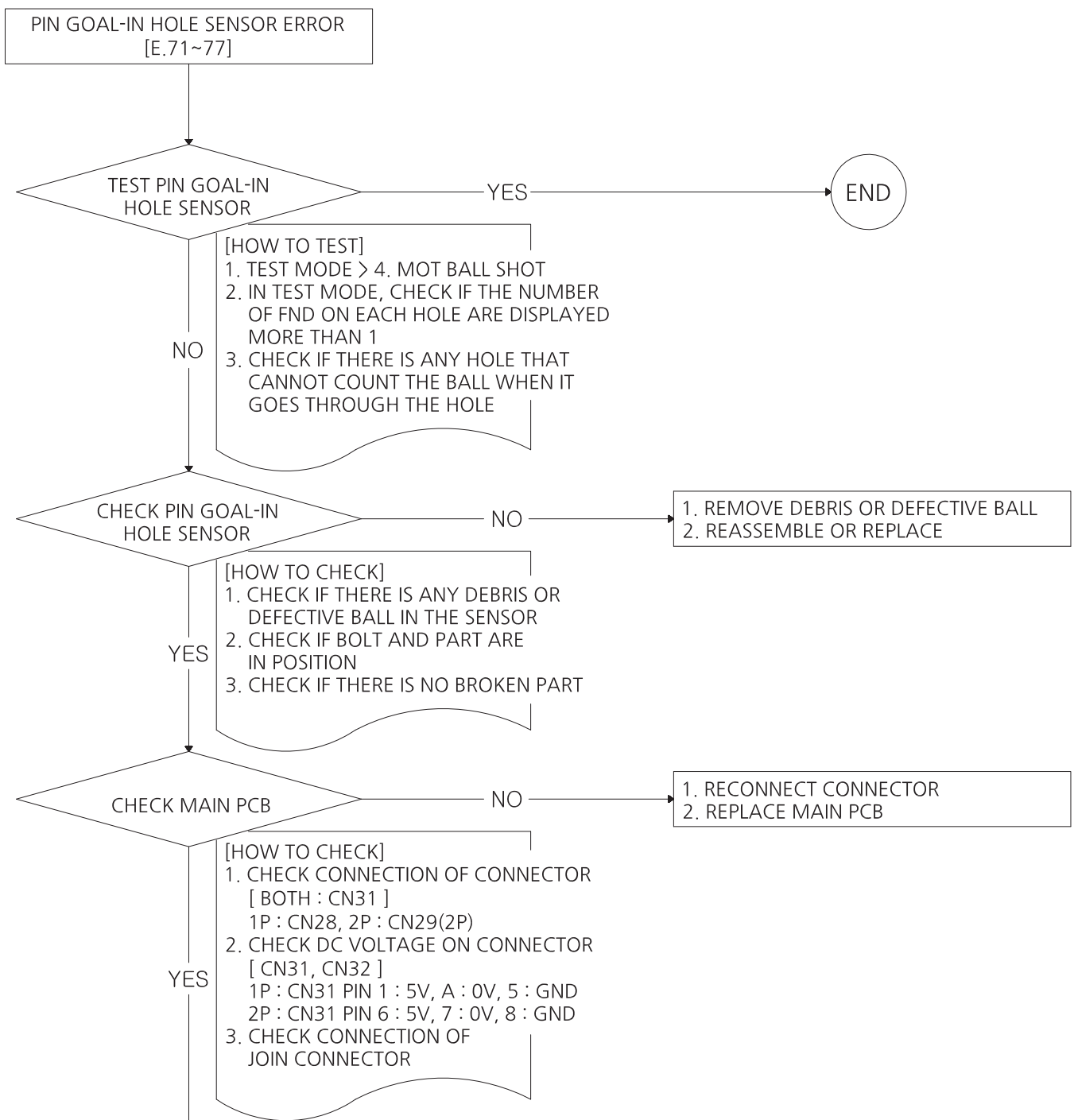
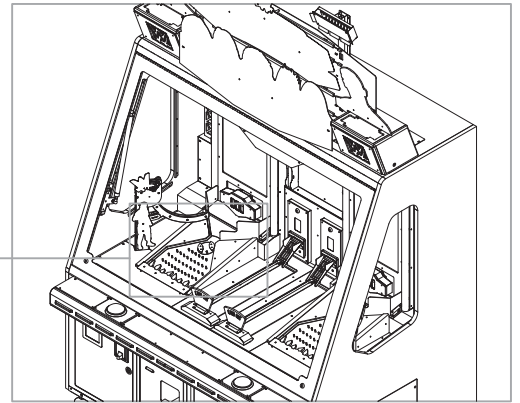
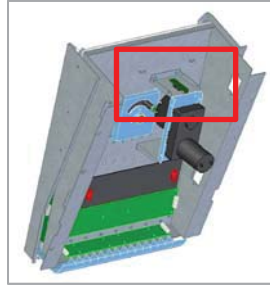

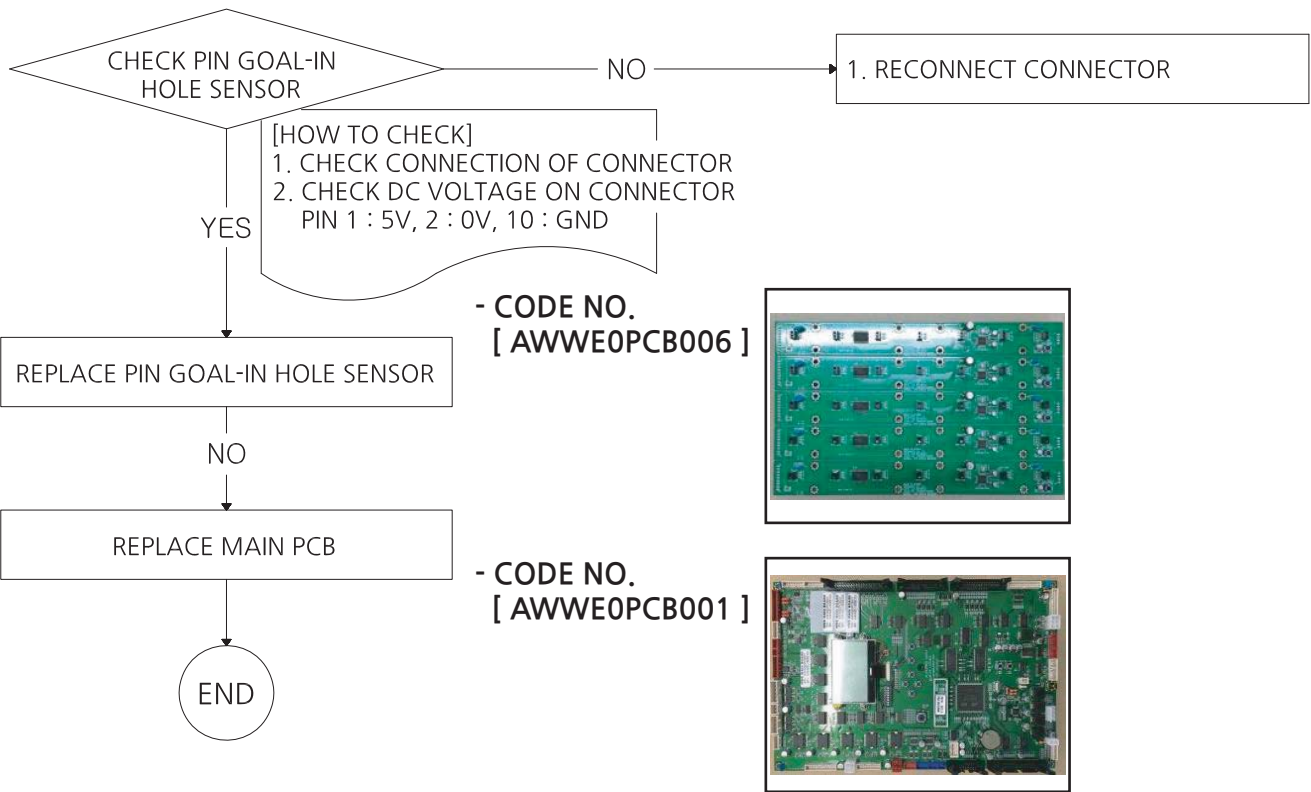

\* General check up : Check the supply voltage and wiring connection properly  
 \* "NO" : Means faulty of the check up result.

## 5-11. BALL ELEVATOR JAM ERROR [E.61] - IN CASE THE ELEVATOR MOTOR IS PROBLEM

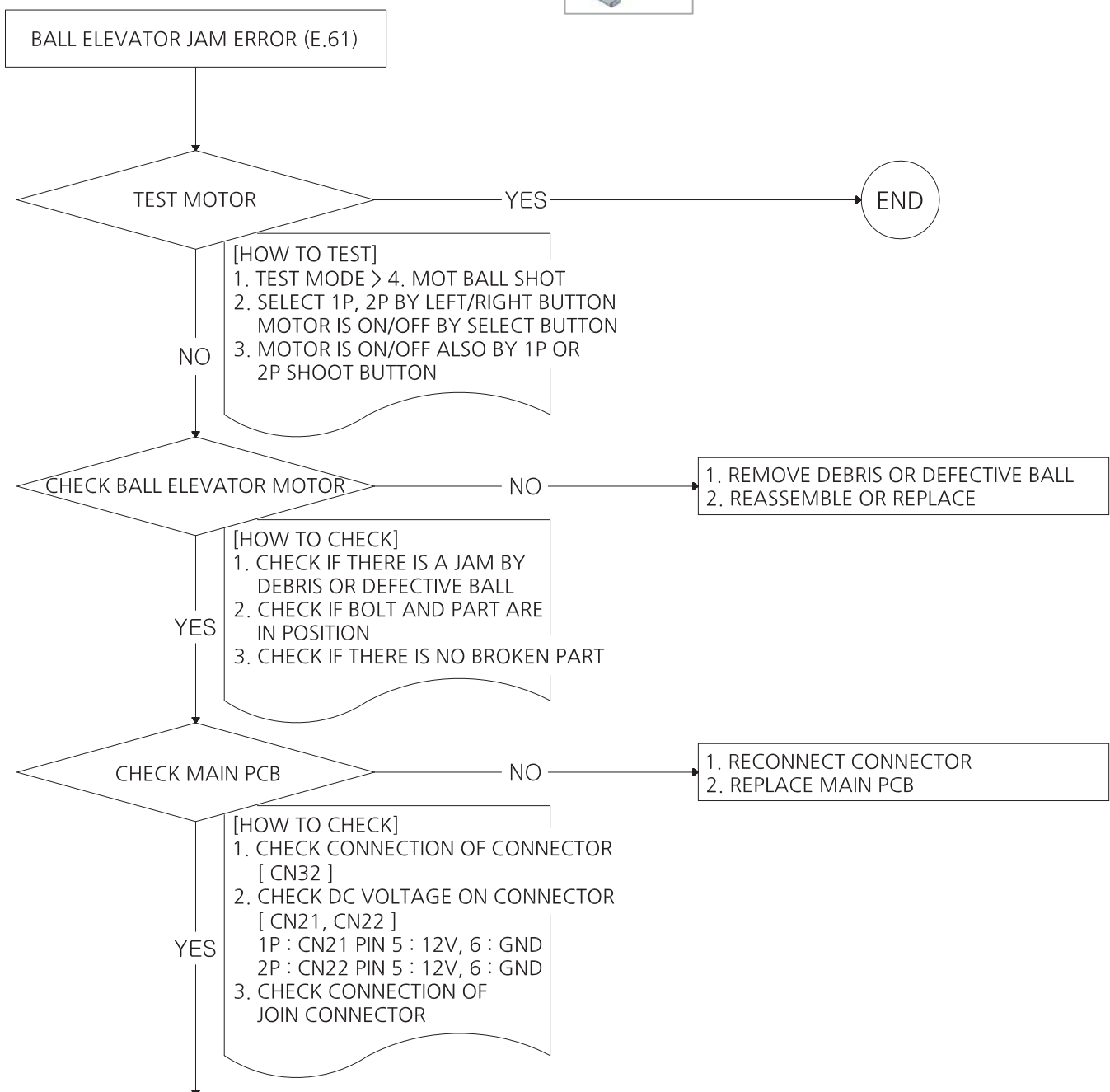
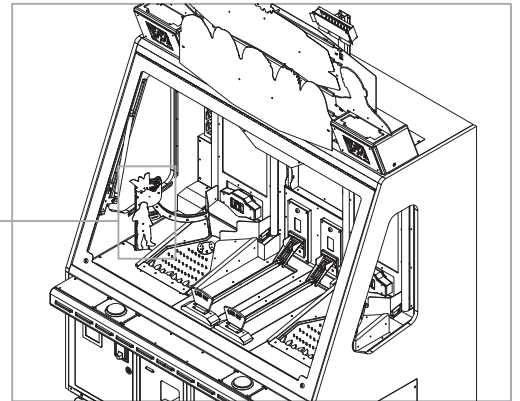
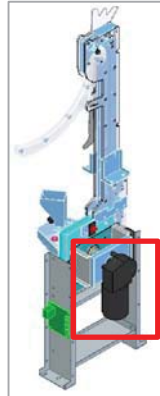



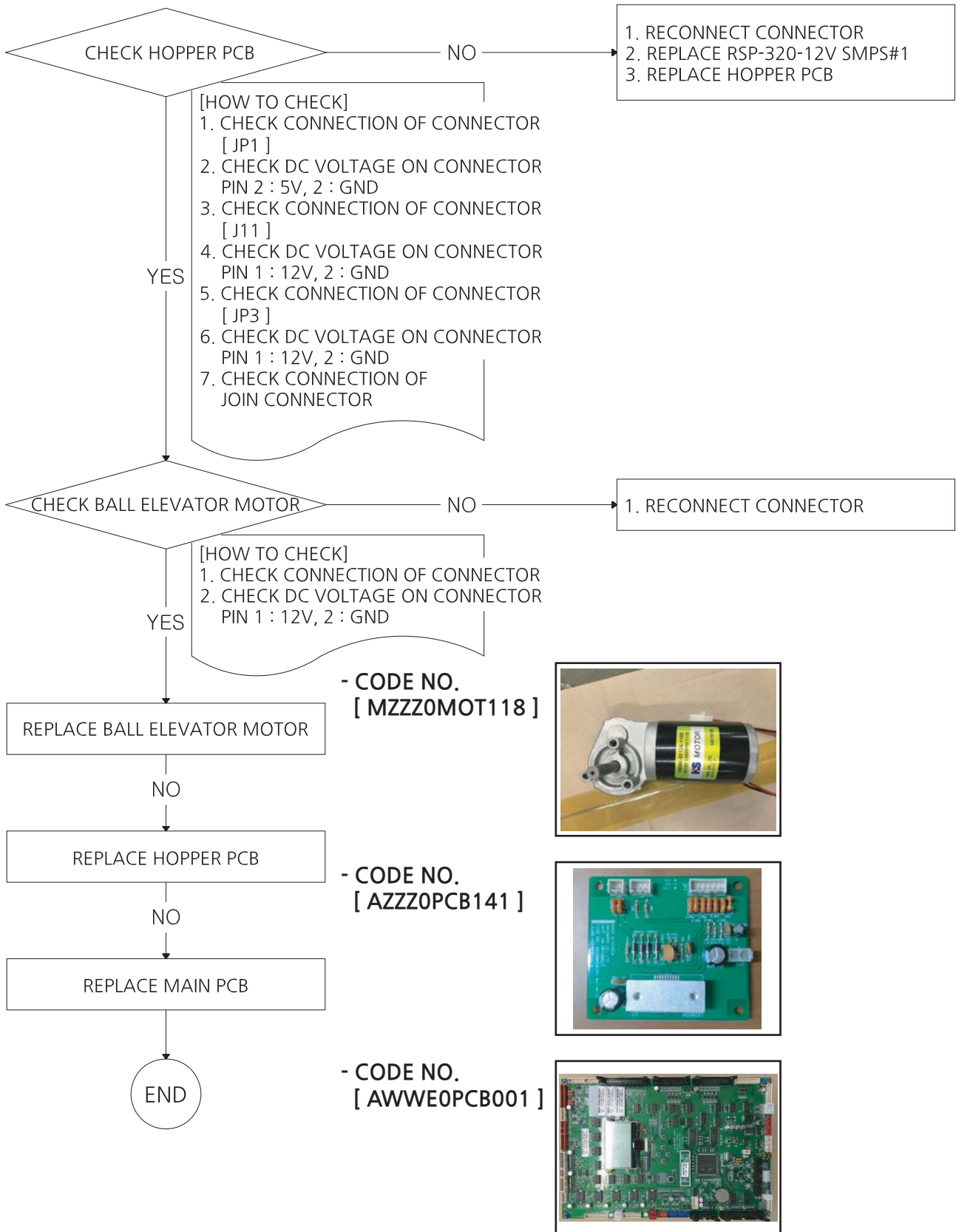

\* General check up : Check the supply voltage and wiring connection properly  
 \* "NO" : Means faulty of the check up result.

## 5-12. BALL ELEVATOR JAM ERROR [E.61] - IN CASE THE ELEVATOR MOTOR ENCODER SENSOR IS PROBLEM

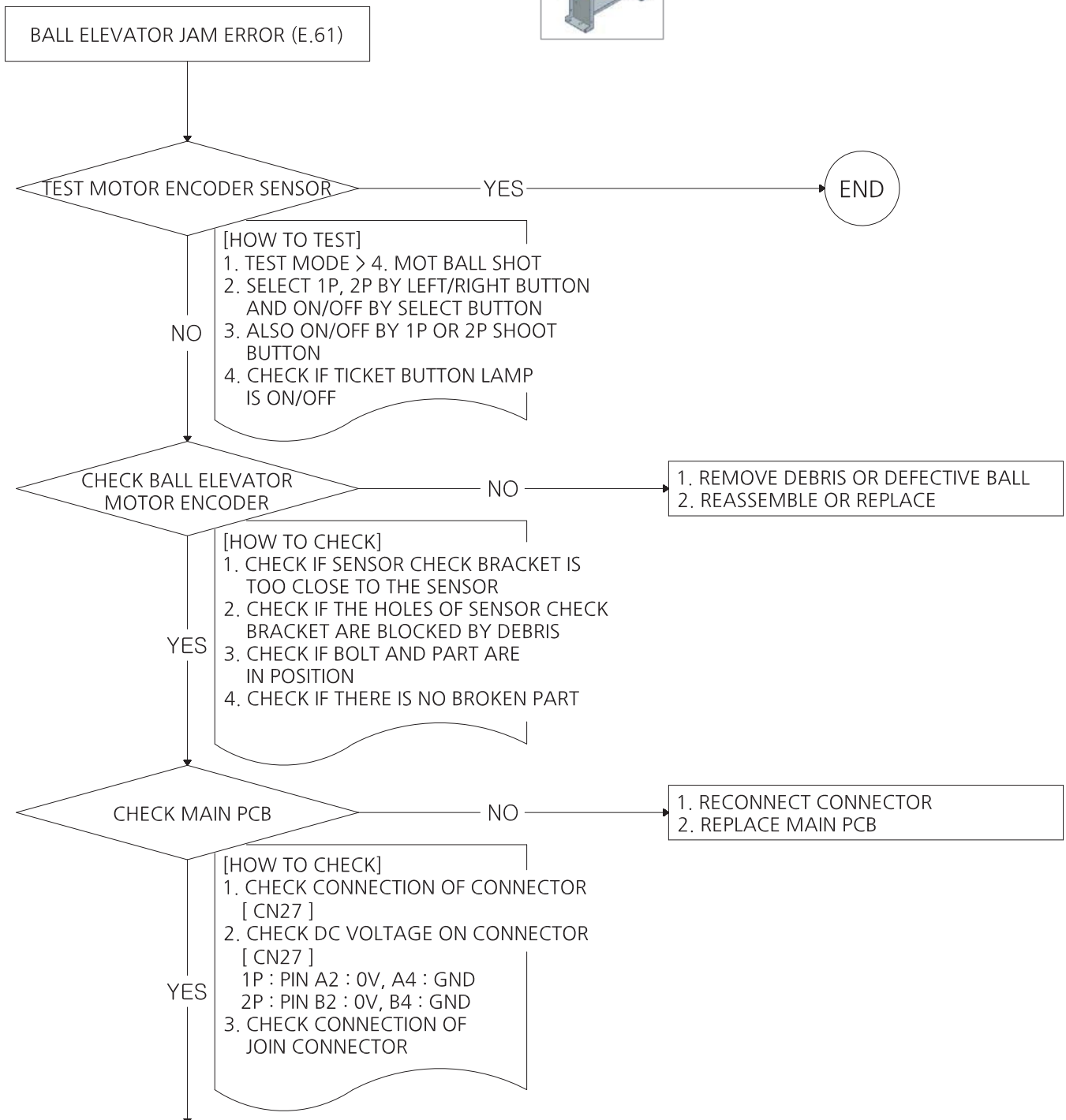
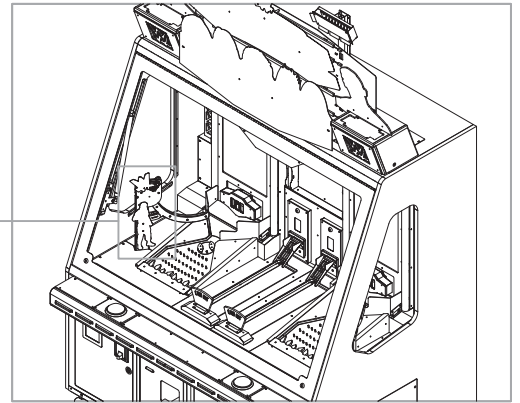
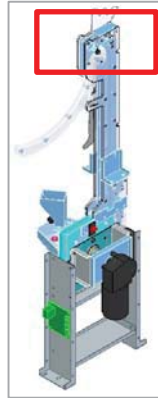

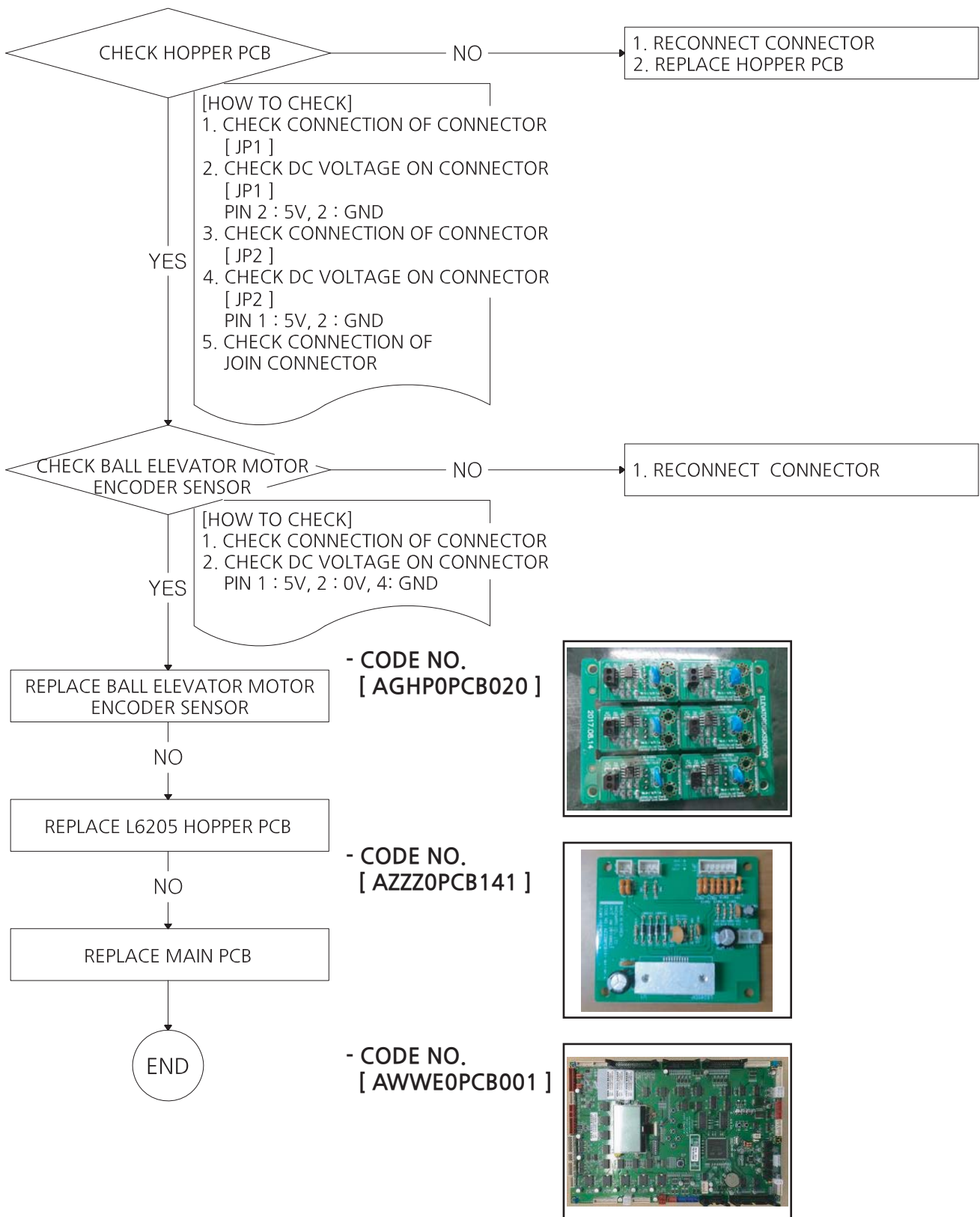

\* General check up : Check the supply voltage and wiring connection properly  
 \* "NO" : Means faulty of the check up result.

## 5-13. BALL ELEVATOR SENSOR ERROR [E.62] - IN CASE UPPER BALL SENSOR IS PROBLEM

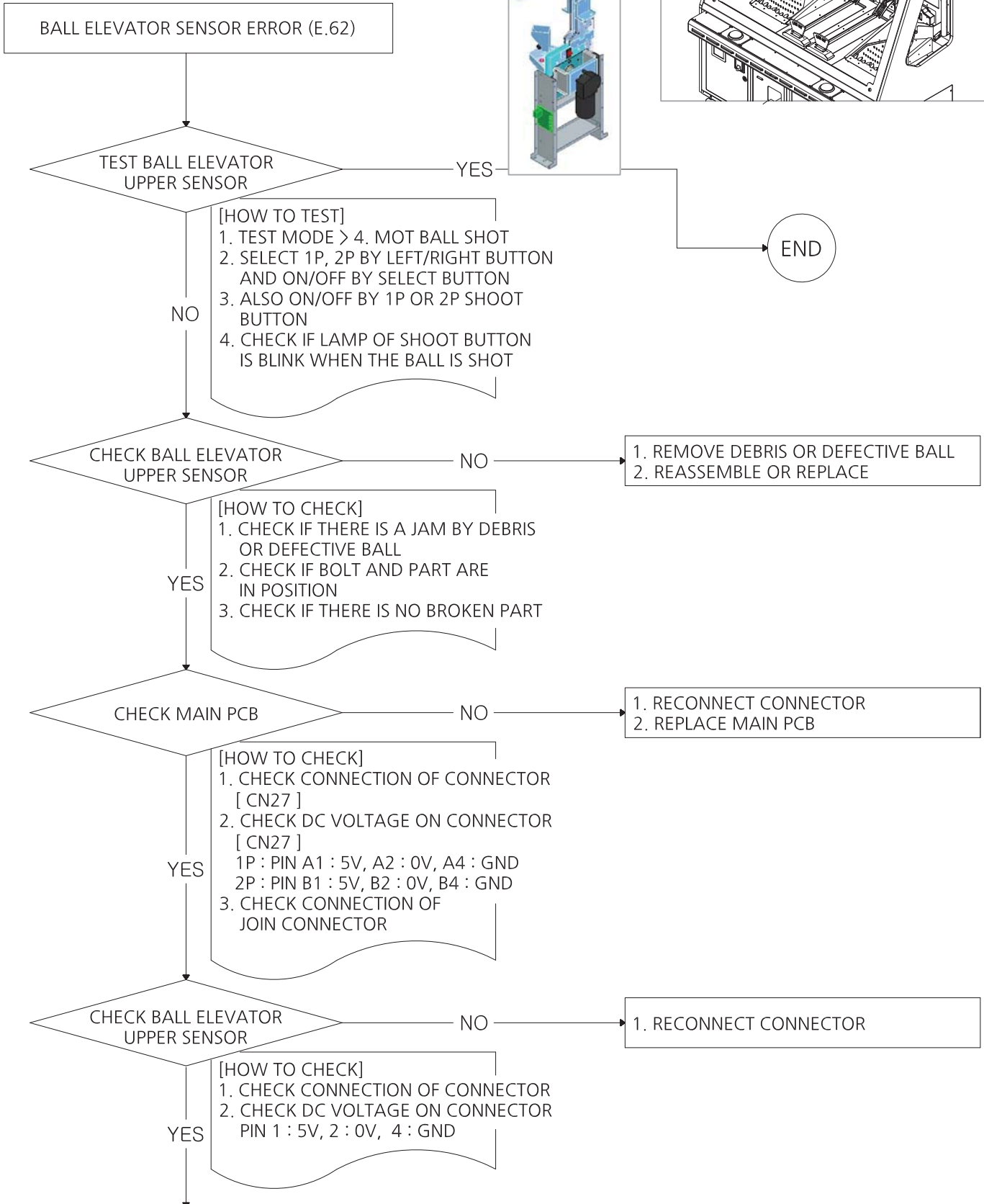
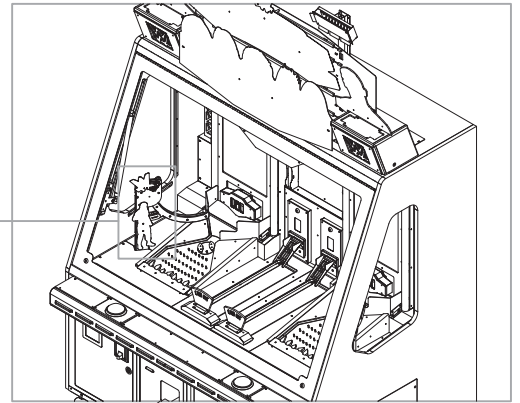

REPLACE BALL ELEVATOR  
UPPER SENSOR

NO

REPLACE MAIN PCB

END

- CODE NO.  
[ AZZZ0PCB103 ]

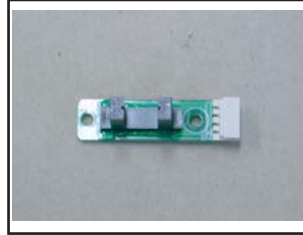

- CODE NO.  
[ AWWE0PCB001 ]



- \* General check up : Check the supply voltage and wiring connection properly
- \* "NO" : Means faulty of the check up result.

## 5-14. CARD DISPENSER ERROR [E.81]

### - NO CARD OR CARD DISPENSER IS PROBLEM

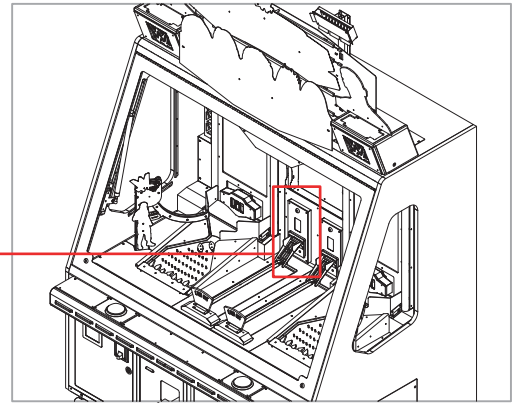

CARD DISPENSER

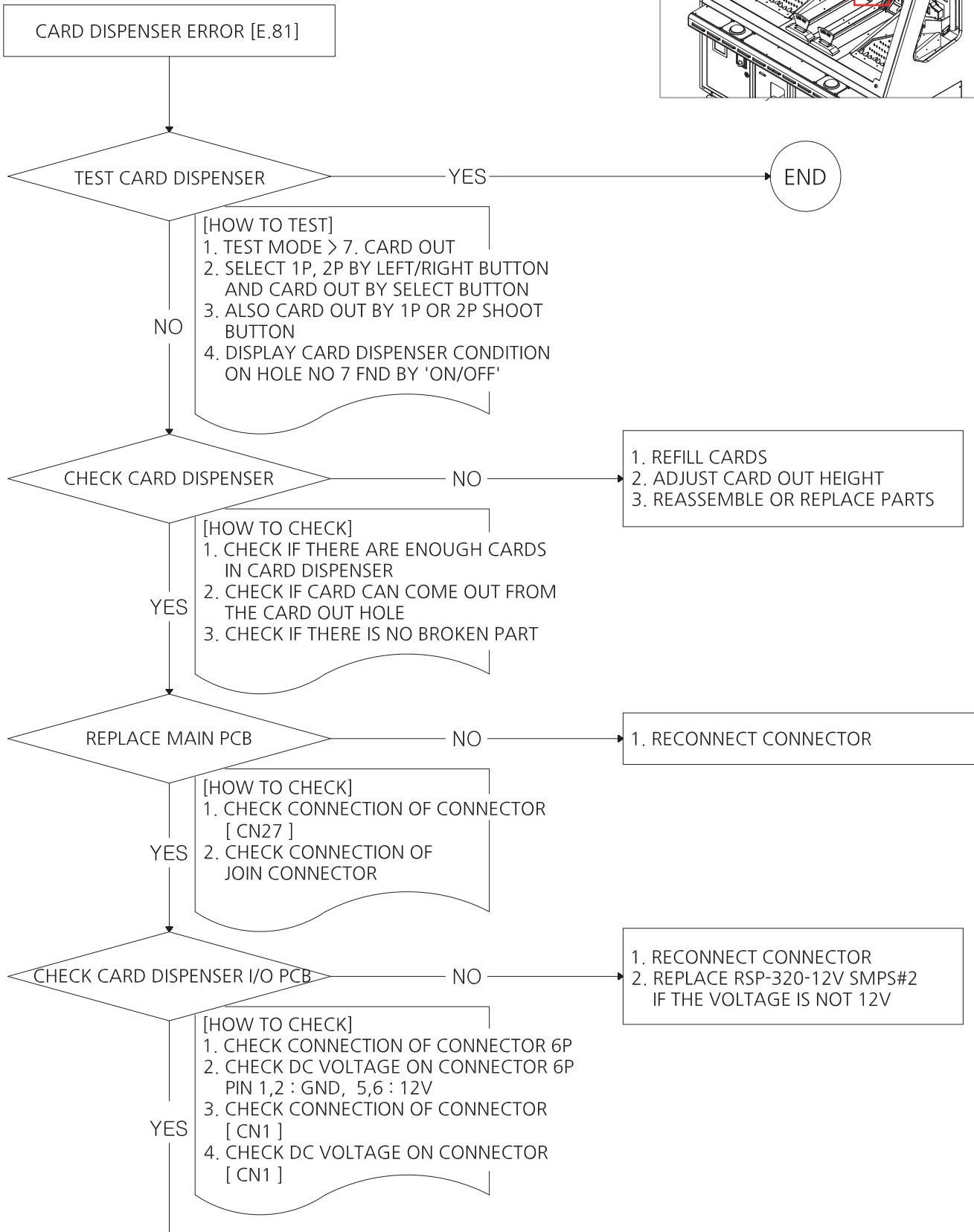

REPLACE CARD DISPENSER MOTOR

NO

REPLACE CARD DISPENSER I/O PCB

NO

REPLACE MAIN PCB

END

- CODE NO.  
[ MZZZ0MOT089 ]



- CODE NO.  
[ ASBP0PCB008 ]



- CODE NO.  
[ AWWEOPCB001 ]

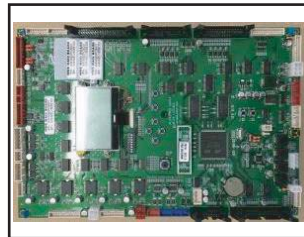

- \* General check up : Check the supply voltage and wiring connection properly
- \* "NO" : Means faulty of the check up result.

## 5-15. CARD DISPENSER ERROR [E.81] - IN CASE CARD KEEPS OUT

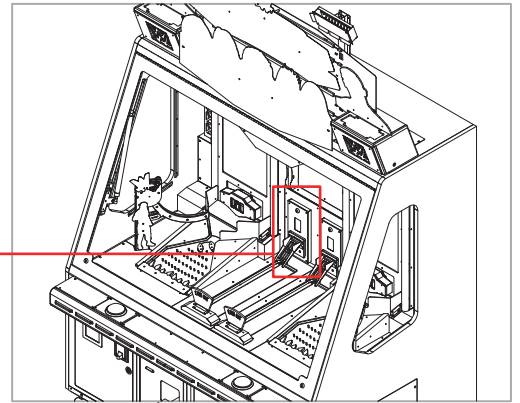

CARD DISPENSER

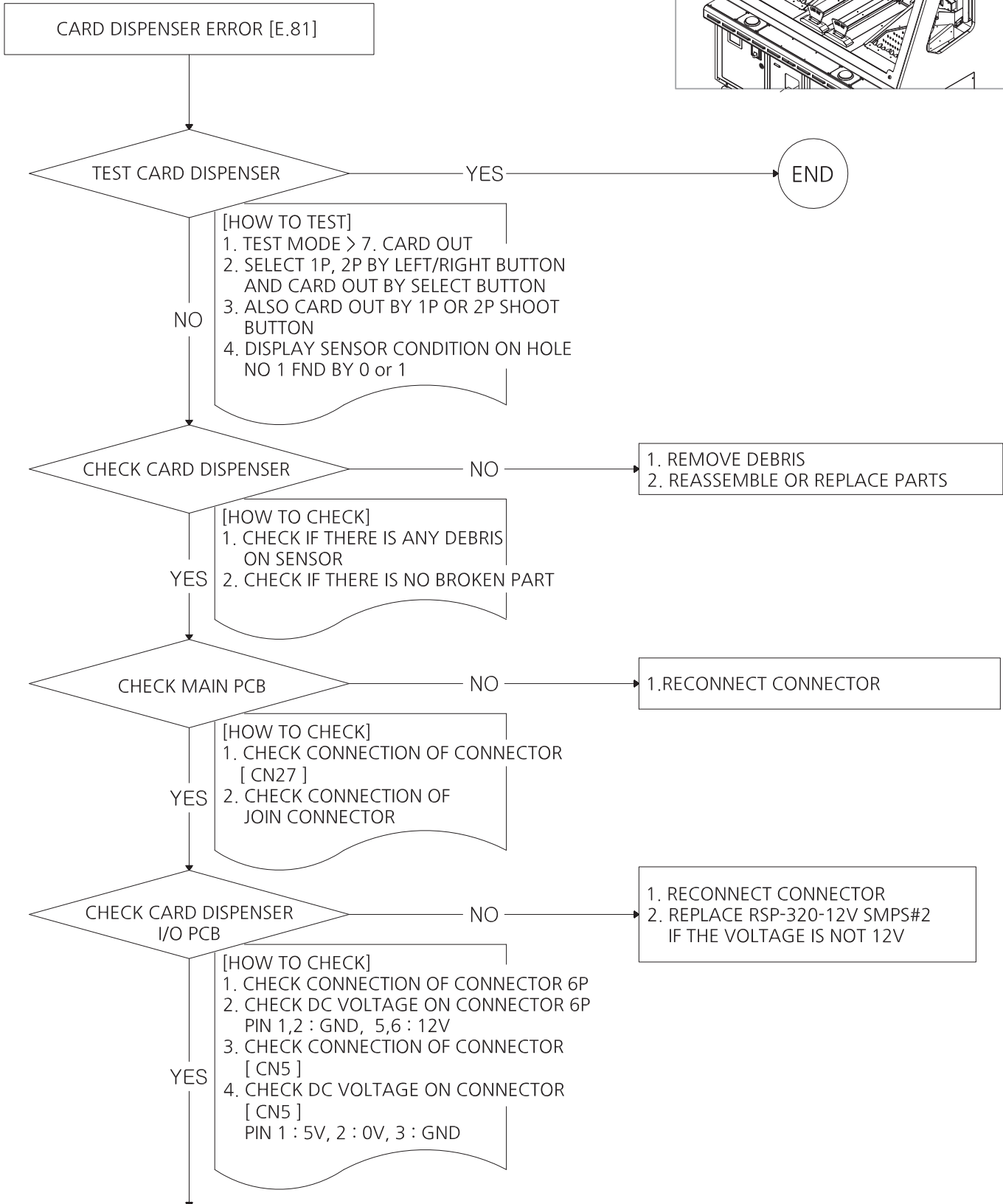



REPLACE CARD DISPENSER  
SENSOR PCB

NO

REPLACE CARD DISPENSER I/O PCB

NO

REPLACE MAIN PCB

END

- CODE NO.  
[ ASBP0PCB009 ]

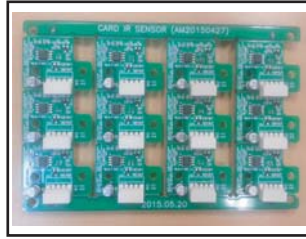

- CODE NO.  
[ ASBP0PCB008 ]

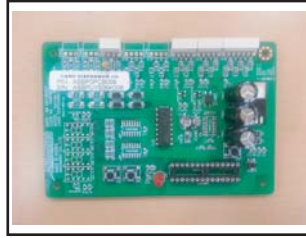

- CODE NO.  
[ AWWEOPCB001 ]

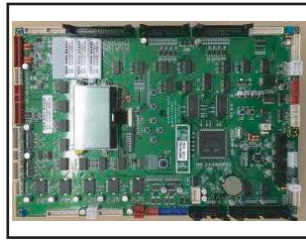

\* General check up : Check the supply voltage and wiring connection properly  
 \* "NO" : Means faulty of the check up result.

## 5-16. SOUND ERROR

SPEAKER

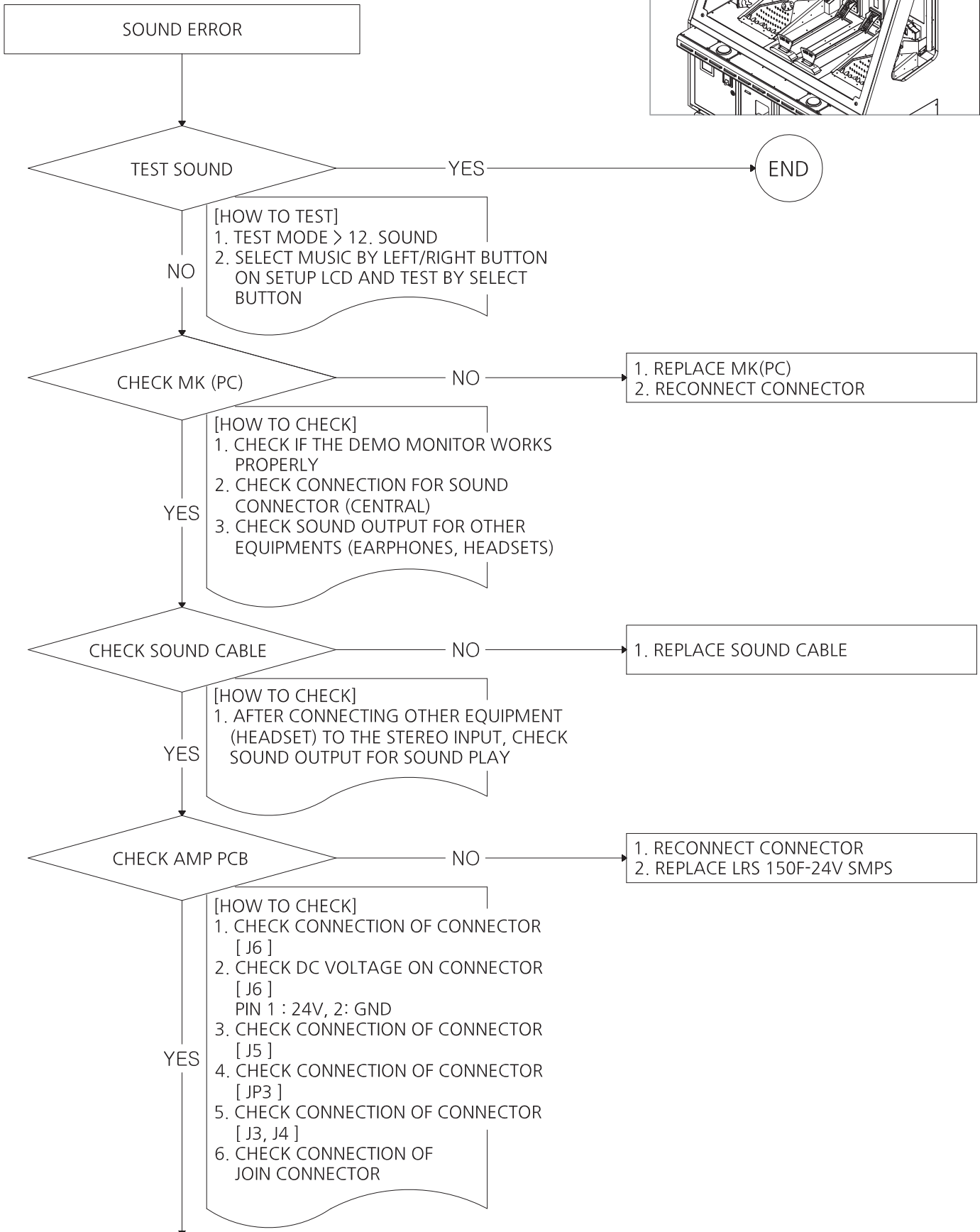
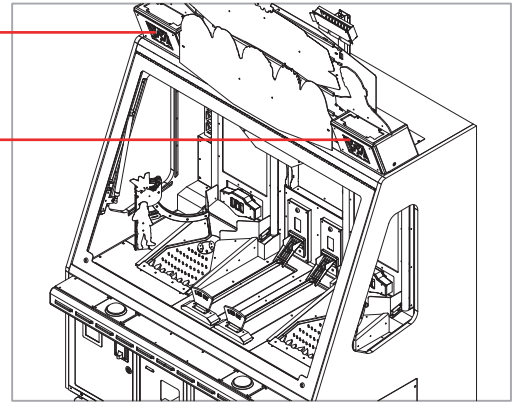

REPLACE VOLUME PCB

NO

REPLACE DIGITAL AMP PCB

END

- CODE NO.  
[ APUJ0PCB005 ]



- CODE NO.  
[ APUJ0PCB002 ]



## 5-17. LED PCB OR FND ERROR

- IN CASE LED PCB OR FND CONNECTED WITH MAIN PCB IS PROBLEM

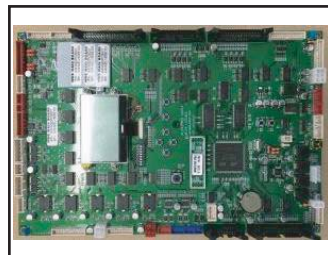
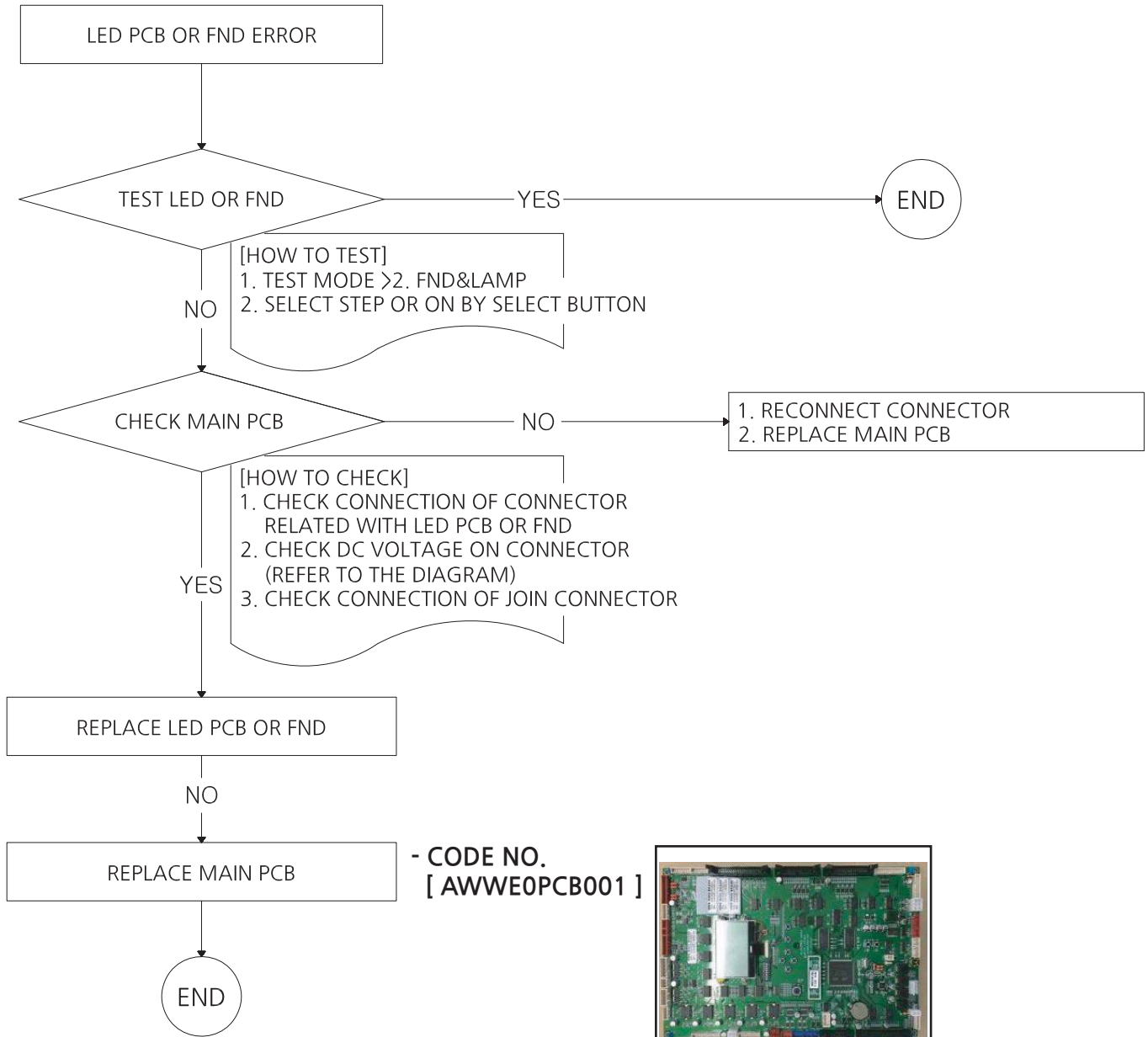

\* General check up : Check the supply voltage and wiring connection properly  
 \* "NO" : Means faulty of the check up result.

## 5-18. 2813 LED PCB ERROR

- IN CASE 2813LED PCB CONNECTED WITH  
 2813 I/O PCB IS PROBLEM

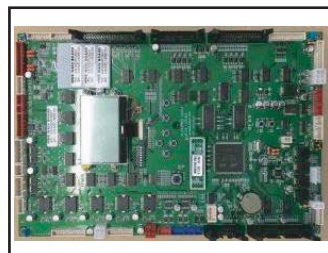
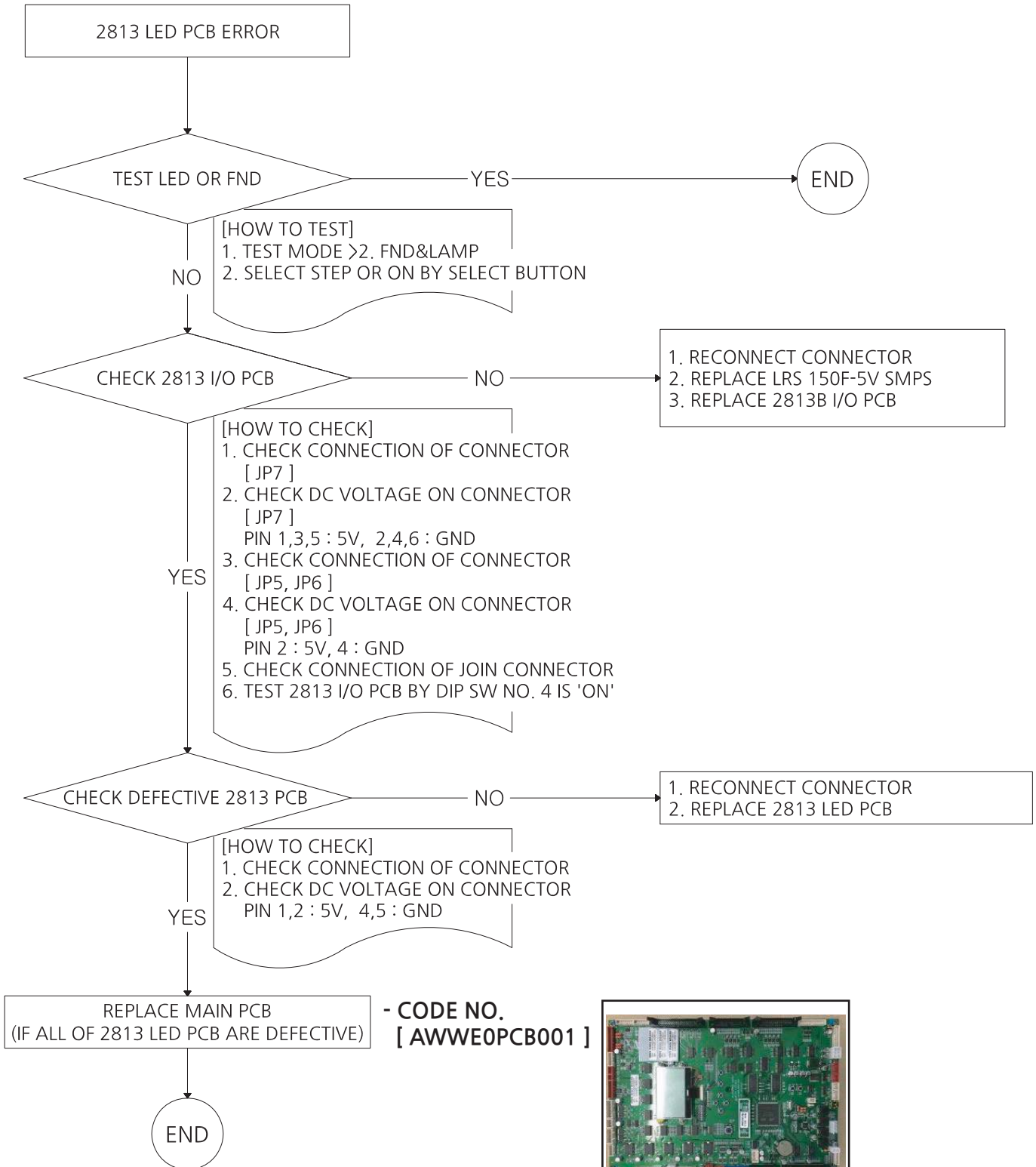

# 6. EXPLODED VIEW

## 6-1. MAIN CABINET PART

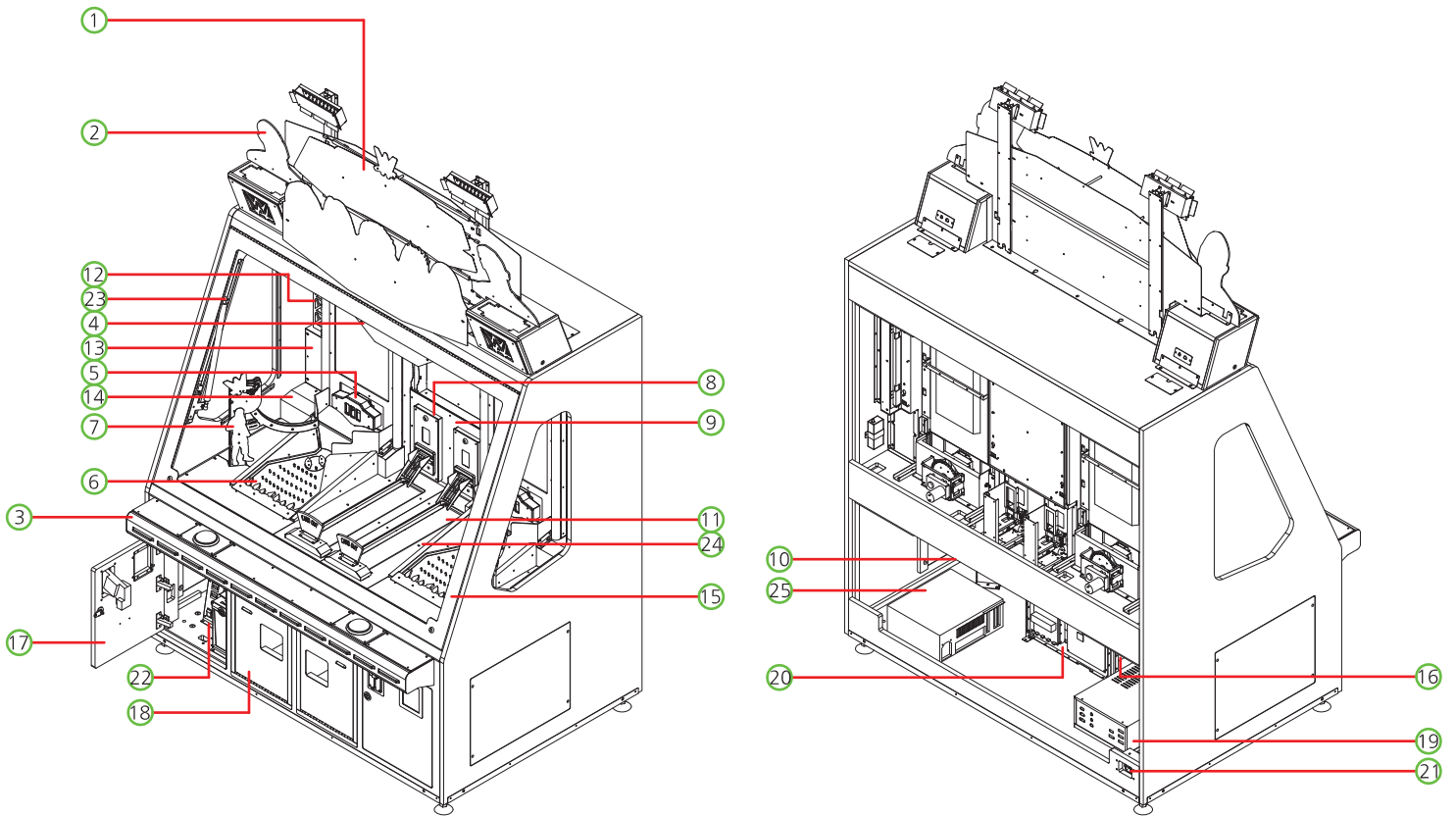

NO.	PART NAME	SPEC.	QUANTITY	CODE NO.
1	BILLBOARD PART	-	1	-
2	SPEAKER PART	-	2	-
3	BUTTON PALTE PART	-	1	-
4	BONUS DISPLAY PART	-	1	-
5	BONUS TARGET PART	-	1	-
6	PIN BASE PART	-	2	-
7	BALL ELEVATOR RAIL PART	-	2	-
8	CARD DISPENSER PART	-	2	-
9	CARD DISPENSER COVER PART	-	2	-
10	CABINET MIDDLE REAR FRAME PART	-	1	-
11	CARD CONVEYOR PART	-	2	-
12	MONITOR PLATE PART	-	2	-
13	SIDE DISPLAY LOWER COVER PART	-	2	-
14	MONITOR PLATE LOWER COVER PART	-	2	-
15	FRONT UPPER DOOR PART	-	2	-
16	WOOFER SPEAKER PART	-	1	-
17	FRONT LOWER DOOR PART	-	1	-
18	TICKET DOOR PART	-	2	-
19	SMPS PART	-	1	-
20	MAIN BOARD PART	-	1	-
21	AC INPUT PART	-	1	-
22	CONTROL PANEL PART	-	1	-
23	GAS SPRING	GSB-22X761-30Kg	2	MZZZ0SHO014
24	CARD CONVEYOR COVER ACRYL L, R	ACRYL-2.7t	2	MWWE0ACR017, 018
25	MAIN BOX ASS'Y	-	1	AWWE0SYS001

## 6-2. BILLBOARD PART

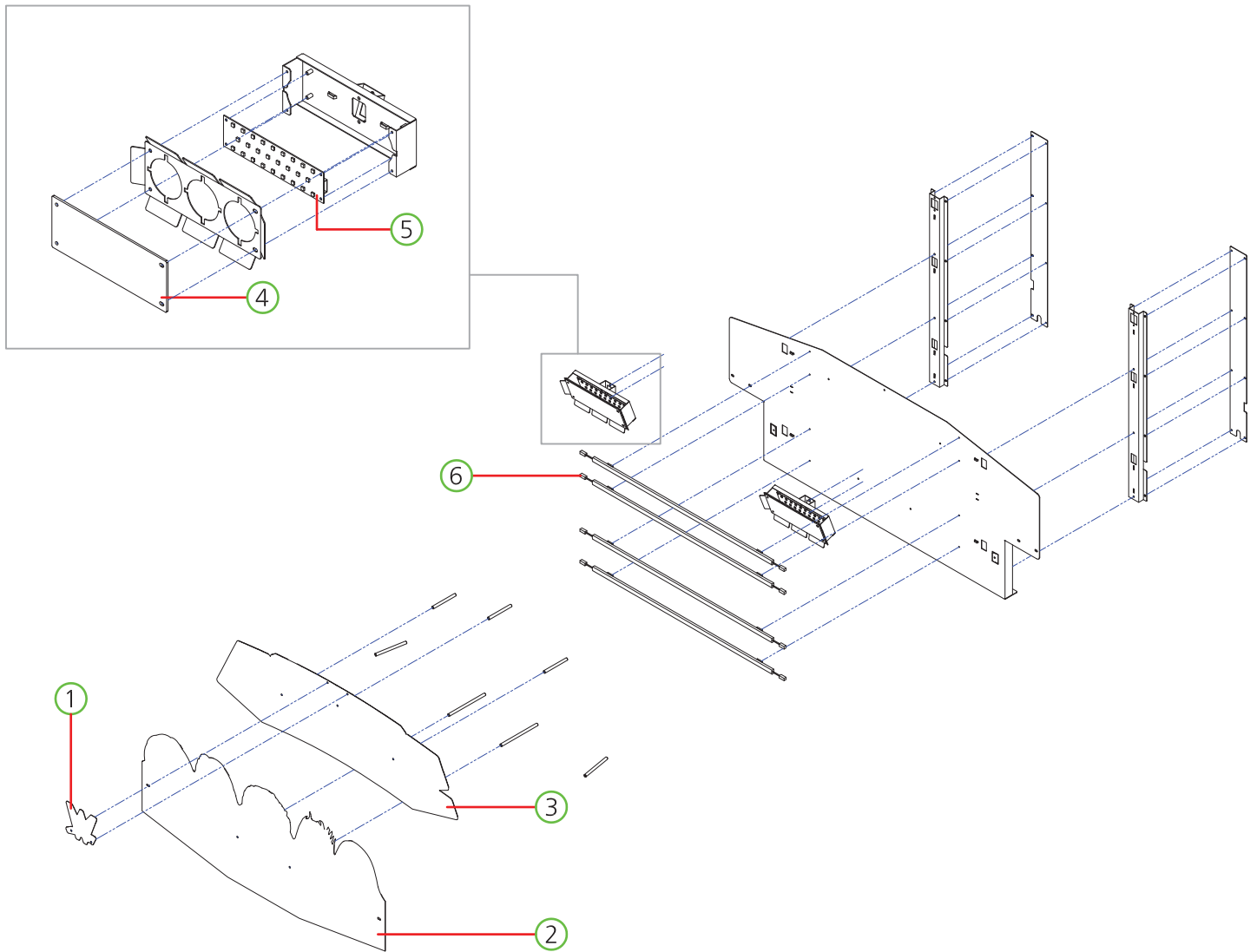

NO.	PART NAME	SPEC.	QUANTITY	CODE NO.
1	BILLBOARD TOP LOGO ACRYL	PET-1.0t	1	MWWE0ACR004
2	BILLBOARD FRONT ACRYL	PET-1.5t	1	MWWE0ACR001
3	BILLBOARD TITLE ACRYL	PET-1.5t	1	MWWE0ACR003
4	BILLBOARD SPOT LED PCB ACRYL	ACRYL-3.0t	2	MWWE0ACR002
5	SPOT LED PCB ASS'Y	-	2	ABAP0PCB008
6	LED BAR 12V PCB ASS'Y	710mm	4	AZZZ0PCB165

### 6-3. SPEAKER PART

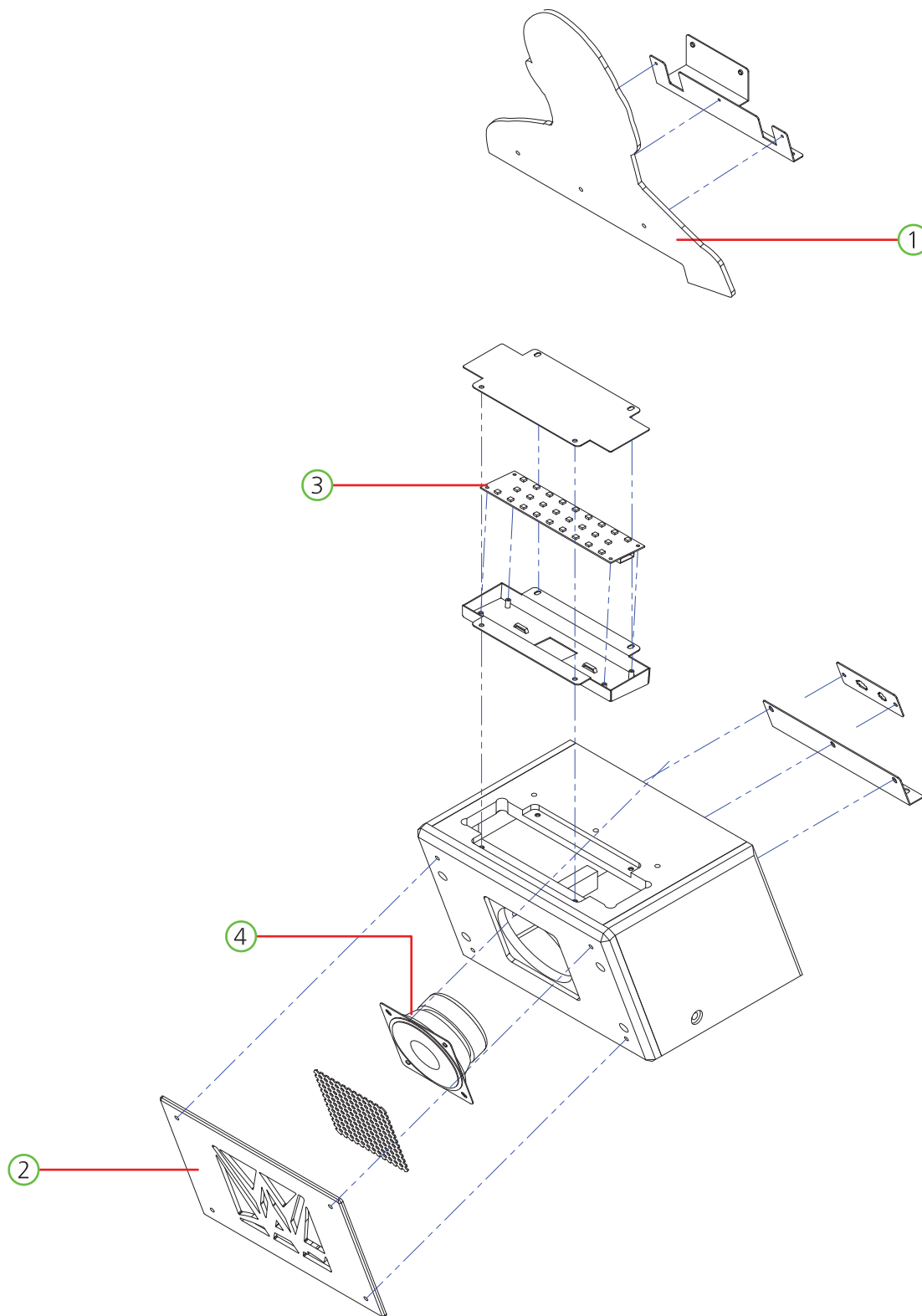

NO.	PART NAME	SPEC.	QUANTITY	CODE NO.
1	BILLBOARD CHARACTER FOMAX-L	FOMAX-5.0t	1	MWWE0ACR006
2	SPEAKER COVER ACRYL	ACRYL-4.5t	1	MWWE0ACR034
3	SPOT LED PCB ASS'Y	-	1	ABAP0PCB008
4	SPEAKER	MID4.5+TW1/2"8Ω"	1	MZZZ0SPE021



## 6-4. BUTTON PLATE PART

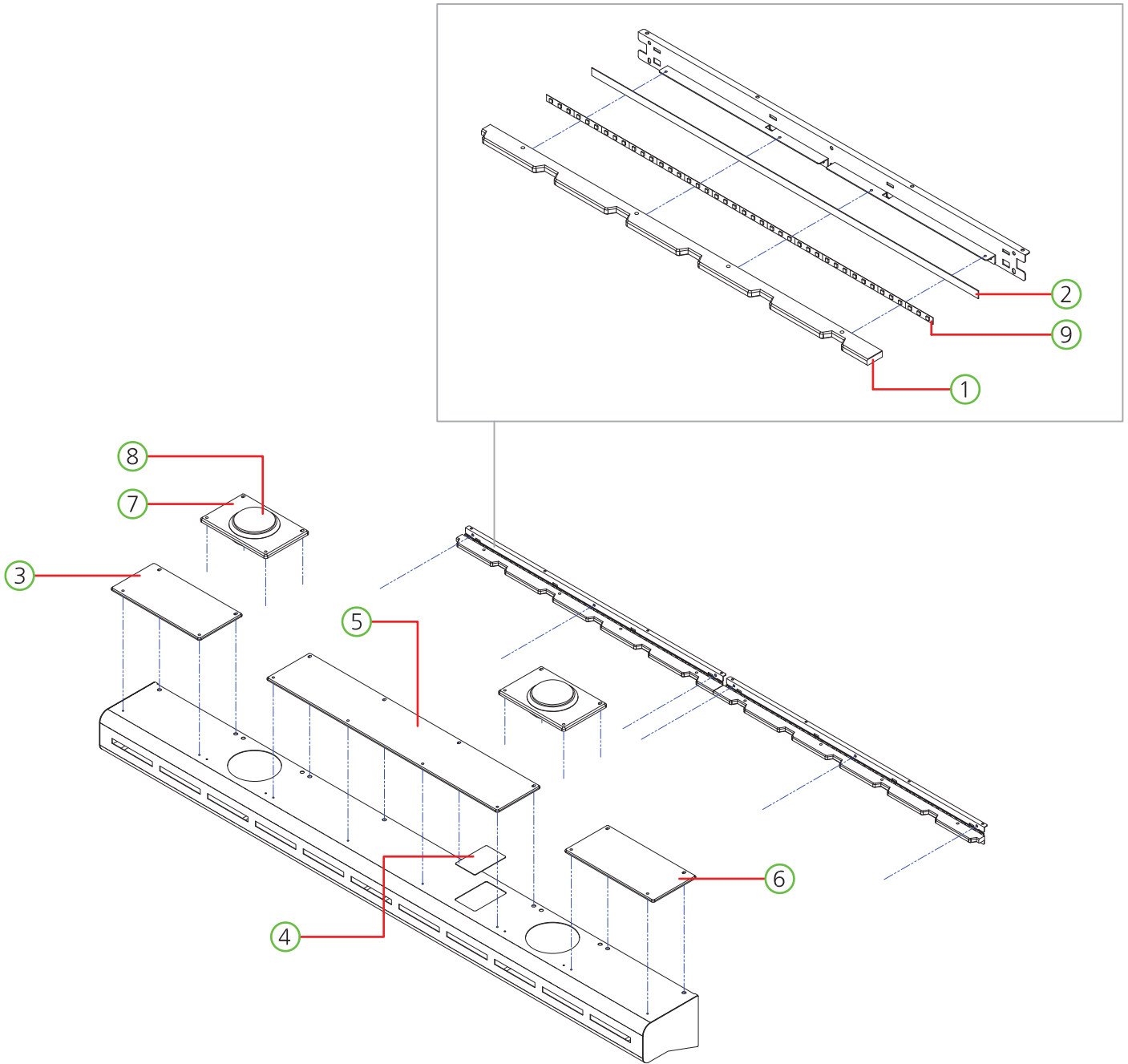

NO.	PART NAME	SPEC.	QUANTITY	CODE NO.
1	BUTTON PLATE FRONT ACRYL	ACRYL-10t	1	MWWE0ACR014
2	BUTTON PLATE FLEXIBLE LED COVER ACRYL	PET-1.0t	1	MWWE0ACR013
3	BUTTON PLATE SIDE ACRYL-L	ACRYL-4.5t	1	MWWE0ACR011
4	BONUS CARD ACRYL	PET-1.0t	1	MWWE0ACR067
5	BUTTON PLATE MIDDLE ACRYL	ACRYL-4.5t	1	MWWE0ACR015
6	BUTTON PLATE SIDE ACRYL-L	ACRYL-4.5t	1	MWWE0ACR012
7	BUTTON COVER ACRYL	ACRYL-8.0t	2	MWWE0ACR065
8	BUTTON ASS'Y	CWB 401-WHITE COLOR ( $\phi$ 100 DOME)_LED TYPE	2	MZZZ0BUT080
9	FLEX_WS2813B_700_NWP_LR	-	1	MELE0LED054

## 6-5. BONUS DISPLAY PART

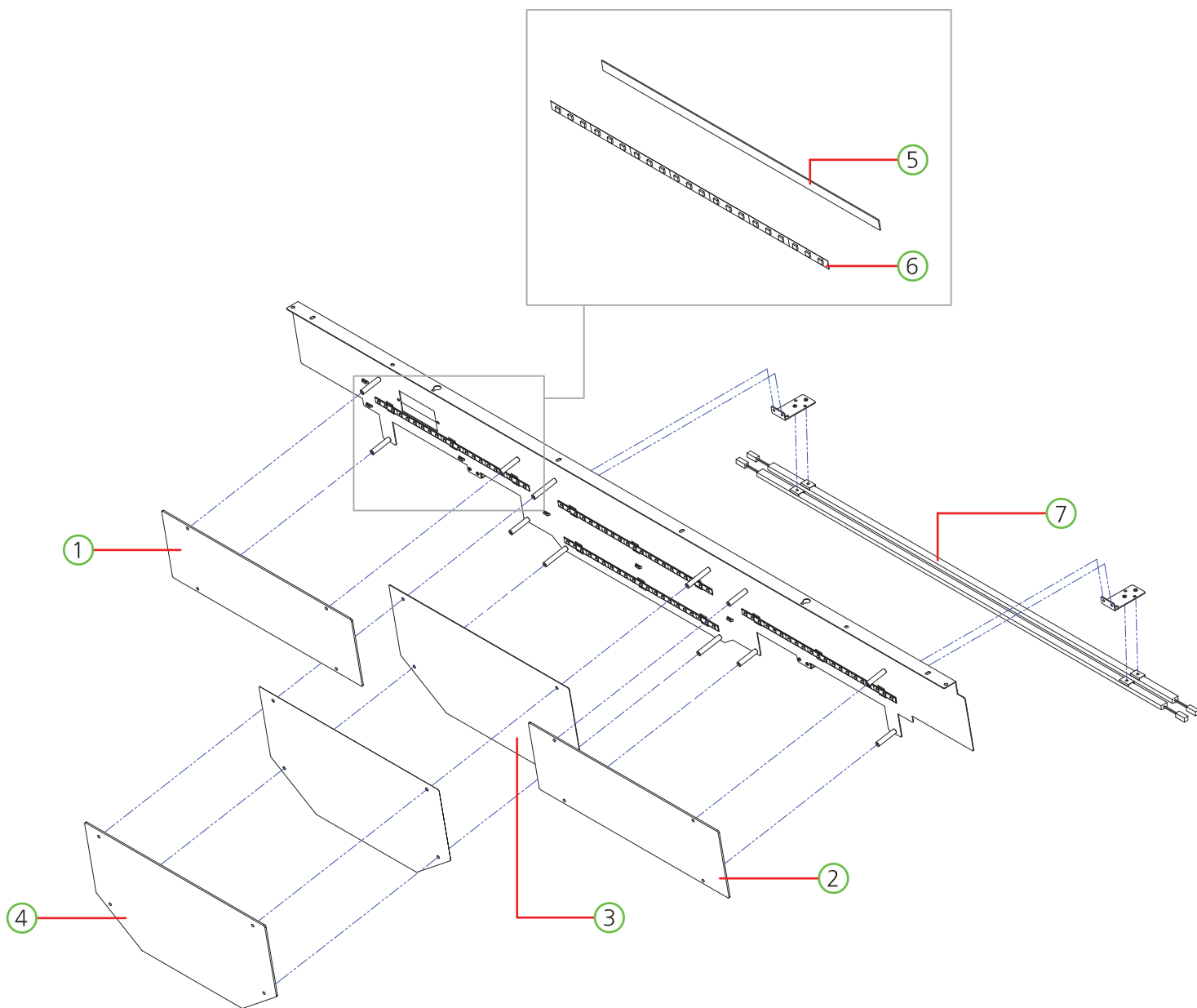

NO.	PART NAME	SPEC.	QUANTITY	CODE NO.
1	CARD DISPLAY COVER ACRYL-L	ACRYL-2.7t	1	MWWE0ACR020
2	CARD DISPLAY COVER ACRYL-R	ACRYL-2.7t	1	MWWE0ACR020
3	BONUS FND REAR COVER ACRYL	PET-1.0t	1	MWWE0ACR010
4	BONUS FND FRONT COVER ACRYL	ACRYL-2.7t	1	MWWE0ACR008
5	BONUS FND LED FIX ACRYL	PET-1.0t	1	MWWE0ACR009
6	FLEX_WHITE_350_NWP_LR	-	1	MELE0LED028
7	12V_LED BAR PCB ASS'Y	-	2	AZZZ0PCB128

## 6-6. BONUS TARGET PART

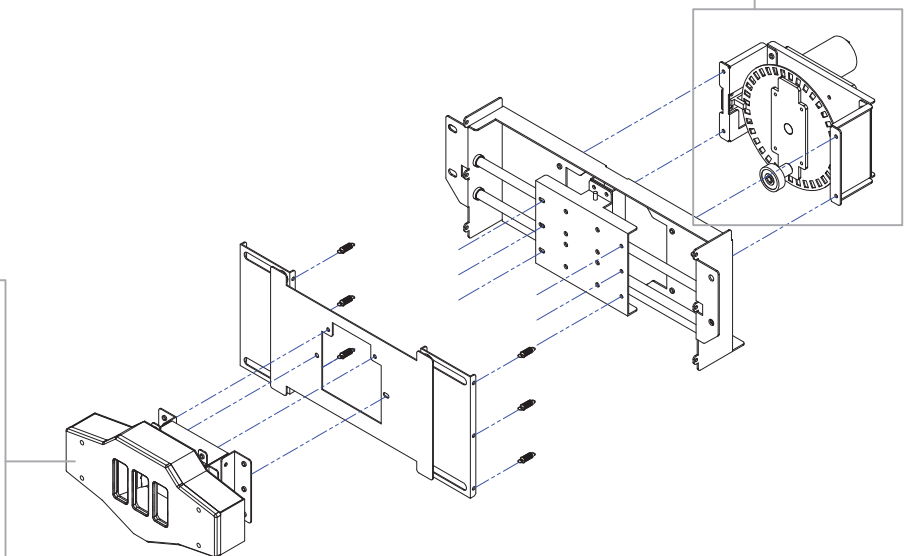
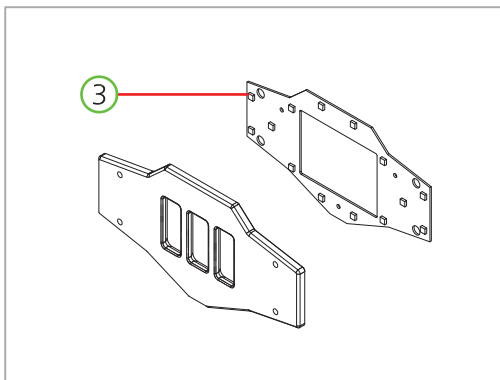
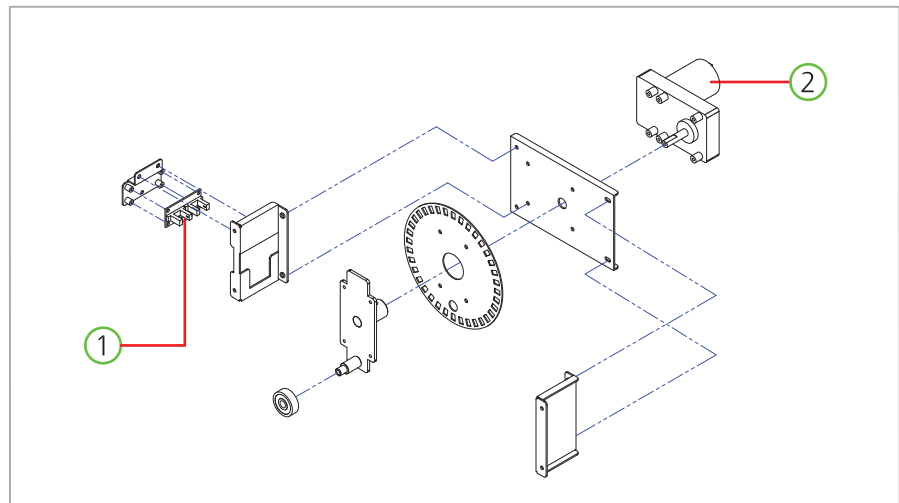

NO.	PART NAME	SPEC.	QUANTITY	CODE NO.
1	PHOTO INT2 PCB ASS'Y	-	1	AWIW0PCB009
2	MOTOR	KGV-0120-ND3657 U1	1	MZZZ0MOT141
3	BONUS TARGET SENSOR PCB ASS'Y	-	1	AWWE0PCB005

## 6-7. PIN BASE PART

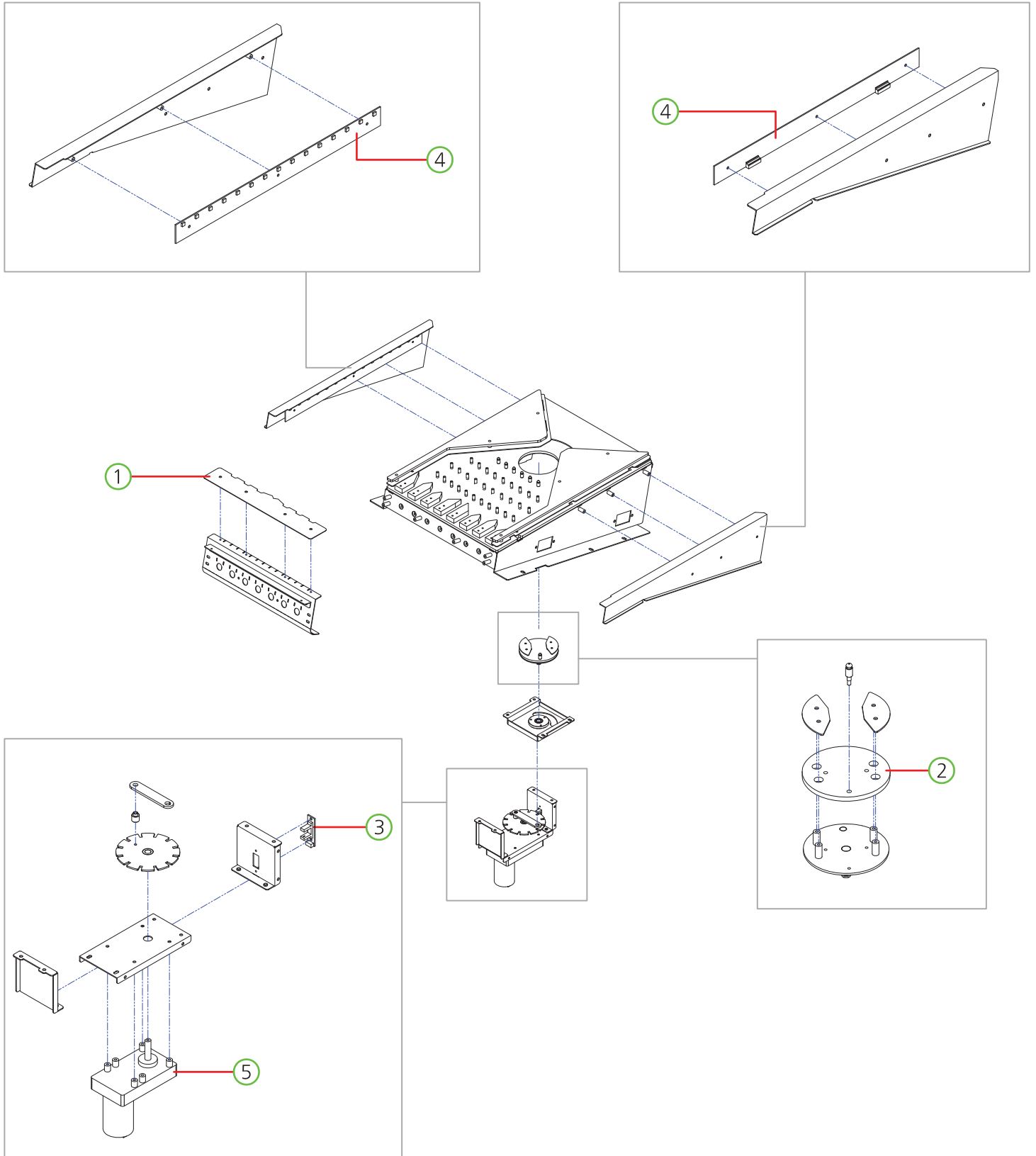

NO.	PART NAME	SPEC.	QUANTITY	CODE NO.
1	PIN BASE CHECKER UPPER COVER ACRYL	PET-1.0t	1	MWWE0ACR056
2	PIN BASE CAM UPPER ACRYL	ACRYL-4.5t	1	MWWE0ACR055
3	PHOTO-INT1 (ANGLE) PCB ASS'Y	-	1	AZZZ0PCB103
4	PIN BASE SIDE LED PCB ASS'Y	-	2	AWWE0PCB004
5	MOTOR	KGV-0120-ND3657 U1	1	MZZZ0MOT141

## 6-8. PIN BASE PART - 01

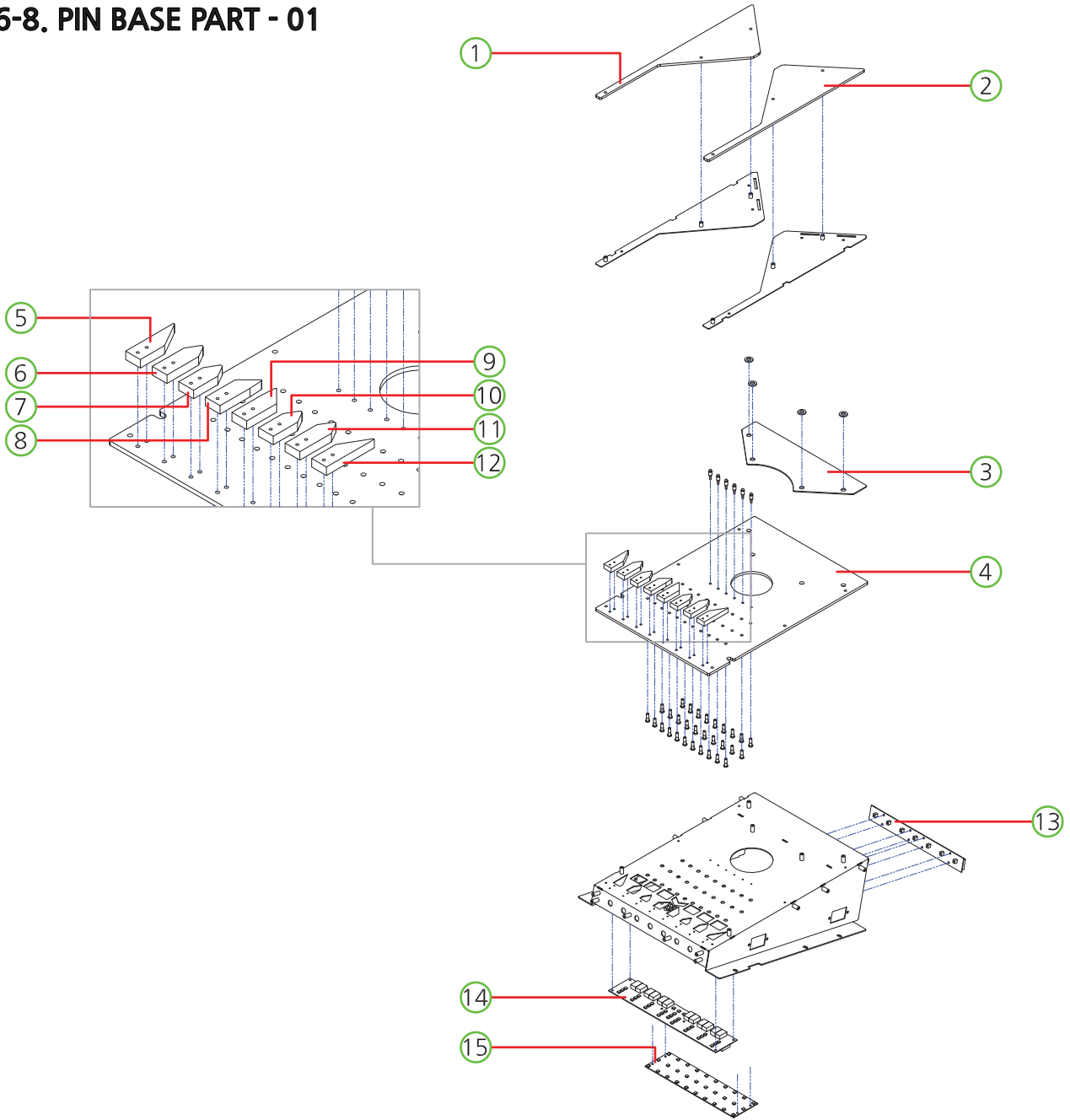

NO.	PART NAME	SPEC.	QUANTITY	CODE NO.
1	PIN BASE SIDE ACRYL-L	ACRYL-4.5t	1	MWWE0ACR057
2	PIN BASE SIDE ACRYL-R	ACRYL-4.5t	1	MWWE0ACR058
3	PIN BASE BALL CUSHION ACRYL	PC-2.0t	1	MWWE0ACR053
4	PIN BASE BOTTOM ACRYL	PC-5.0t	1	MWWE0ACR054
5	PIN CHECKER SIDE ACRYL-L	ACRYL-10t	1	MWWE0ACR063
6	PIN CHECKER MIDDLE OUTER ACRYL	ACRYL-10t	1	MWWE0ACR062
7	PIN CHECKER MIDDLE INNER ACRYL	ACRYL-10t	1	MWWE0ACR061
8	PIN CHECKER BONUS ACRYL-L	ACRYL-10t	1	MWWE0ACR059
9	PIN CHECKER BONUS ACRYL-R	ACRYL-10t	1	MWWE0ACR060
10	PIN CHECKER MIDDLE INNER ACRYL	ACRYL-10t	1	MWWE0ACR061
11	PIN CHECKER MIDDLE OUTER ACRYL	ACRYL-10t	1	MWWE0ACR062
12	PIN CHECKER SIDE ACRYL-R	ACRYL-10t	1	MWWE0ACR064
13	PIN CHECKER SENSOR PCB ASS'Y	-	1	AWWE0PCB006
14	PIN CHECKER FND PCB ASS'Y	-	1	AWWE0PCB007
15	PIN BASE LED PCB ASS'Y	-	1	AGHP0PCB019

## 6-9. BALL ELEVATOR RAIL PART

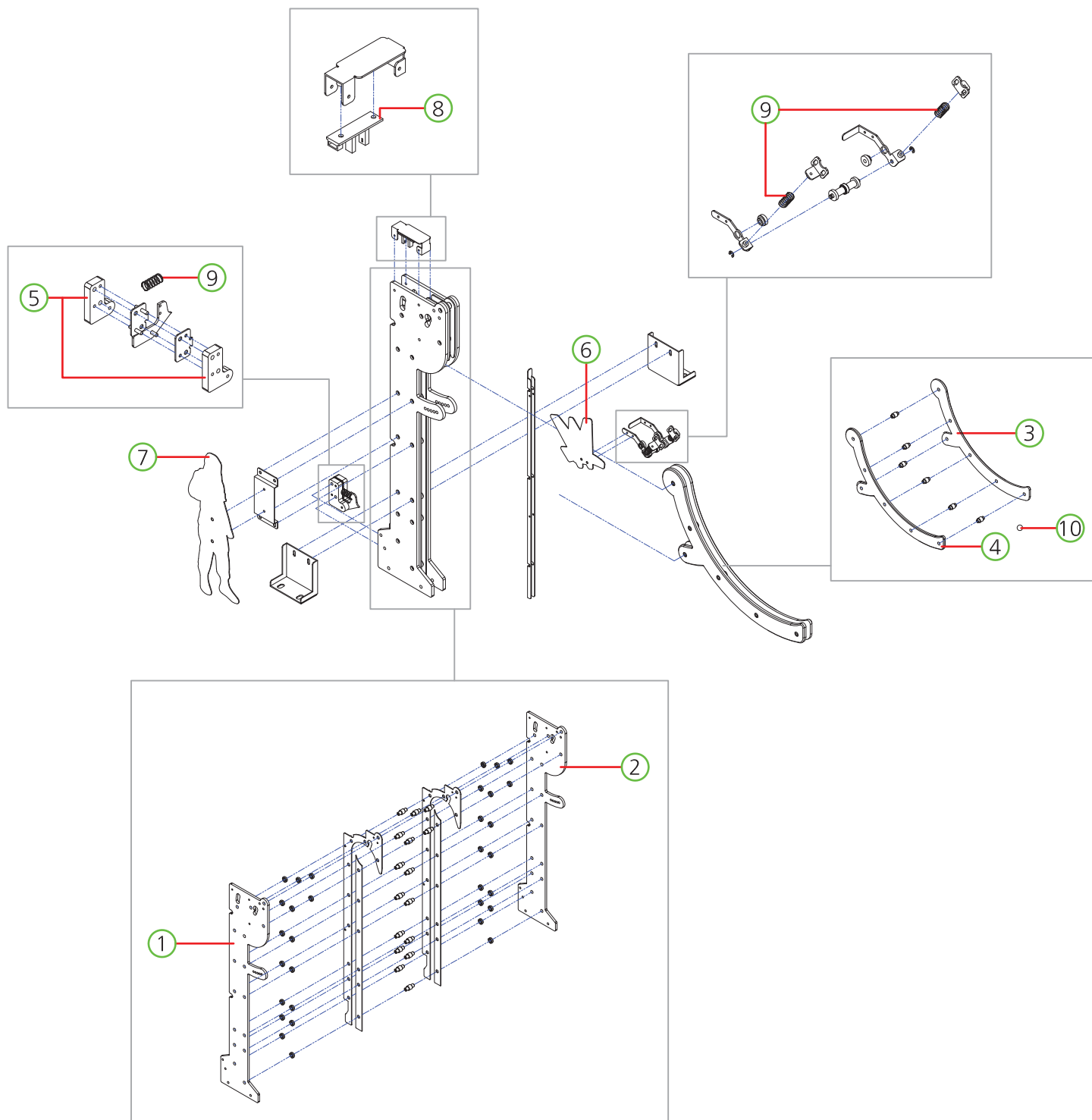

NO.	PART NAME	SPEC.	QUANTITY	CODE NO.
1	BALL ELEVATOR RAIL SIDE ACRYL	PC-5.0t	1	MWWE0ACR048
2	BALL ELEVATOR RAIL SIDE ACRYL	PC-5.0t	1	MWWE0ACR048
3	BALL ELEVATOR CHUTE SIDE ACRYL-L	ACRYL-5.0t	1	MWWE0ACR040
4	BALL ELEVATOR CHUTE SIDE ACRYL-R	ACRYL-5.0t	1	MWWE0ACR041
5	BALL ELEVATOR BRAKE GUIDE ACRYL	ACRYL-8.0t	1	MWWE0ACR039
6	BALL ELEVATOR TOP SIDE DECO ACRYL-L	PET-1.0t	1	MWWE0ACR051
7	BALL ELEVATOR SIDE DECO-L	PET-1.0t	1	MWWE0ACR049
8	PHOTO-INT1 (ANGLE) PCB ASS'Y	ANGLE TYPE	1	AZZZ0PCB103
9	Z MOTOR PART TENSION SPRING	-	3	MWID0SPR001
10	BALL	∅15_STEEL	85	MZZZ0BLL006

# 6-10. BILLBOARD BODY PART

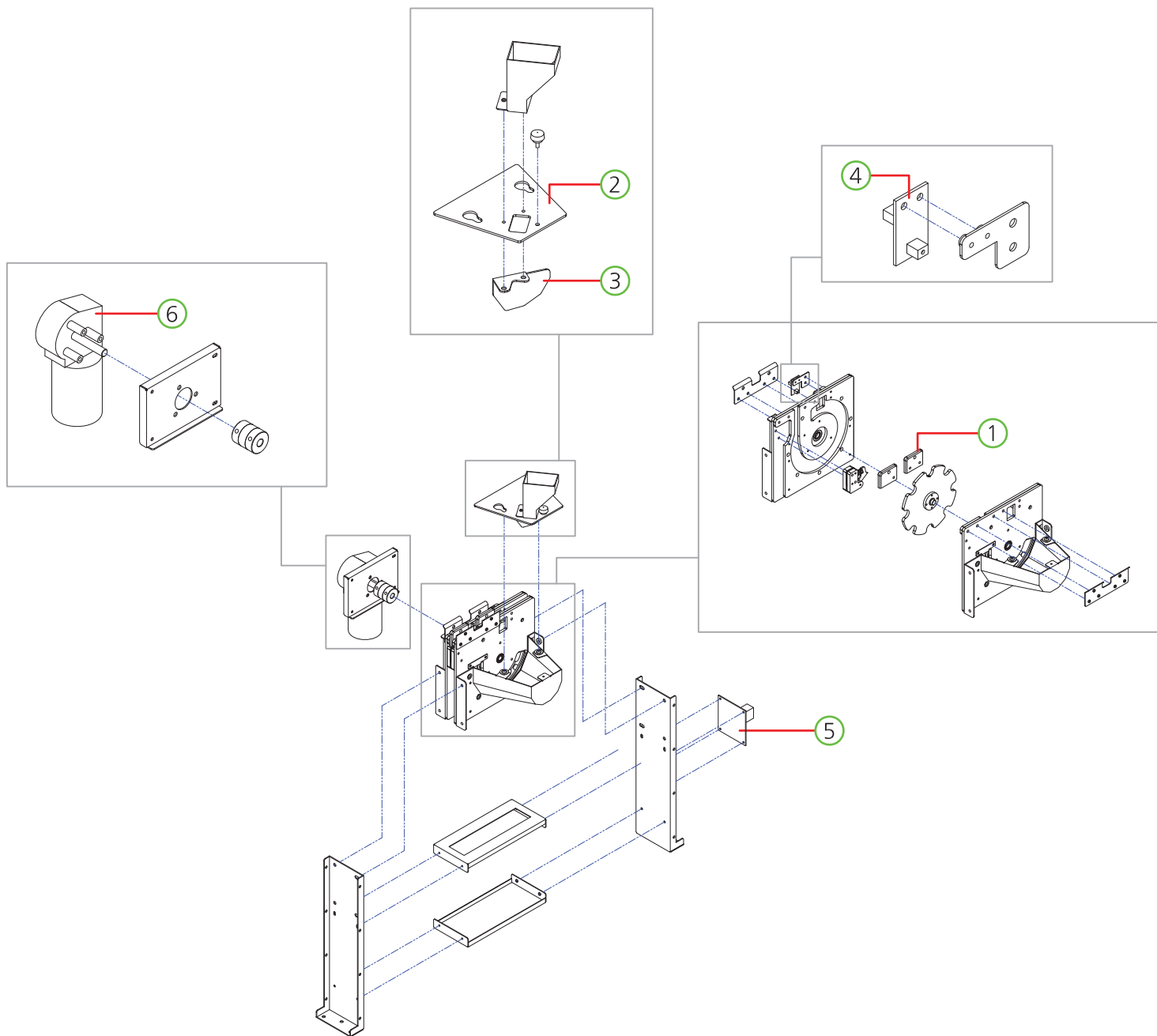

NO.	PART NAME	SPEC.	QUANTITY	CODE NO.
1	BALL ELEVATOR MOVEMENT SPACER ACRYL	ACRYL-8.0t	1	MWWE0ACR047
2	BALL ELEVATOR HOUSING COVER ACRYL	ACRYL-2.7t	1	MWWE0ACR042
3	BALL ELEVATOR HOUSING INNER ACRYL-R	PET-2.0t	1	MWWE0ACR044
4	ELEVATOR DISK SENSOR PCB ASS'Y	-	1	AGHP0PCB020
5	L6205 HOPPER PCB ASS'Y	-	1	AZZZ0PCB141
6	MOTOR	HSW6-5012A, DC12V, 50W, 33RPM	1	MZZZ0MOT118

# 6-11. CARD DISPENSER PART

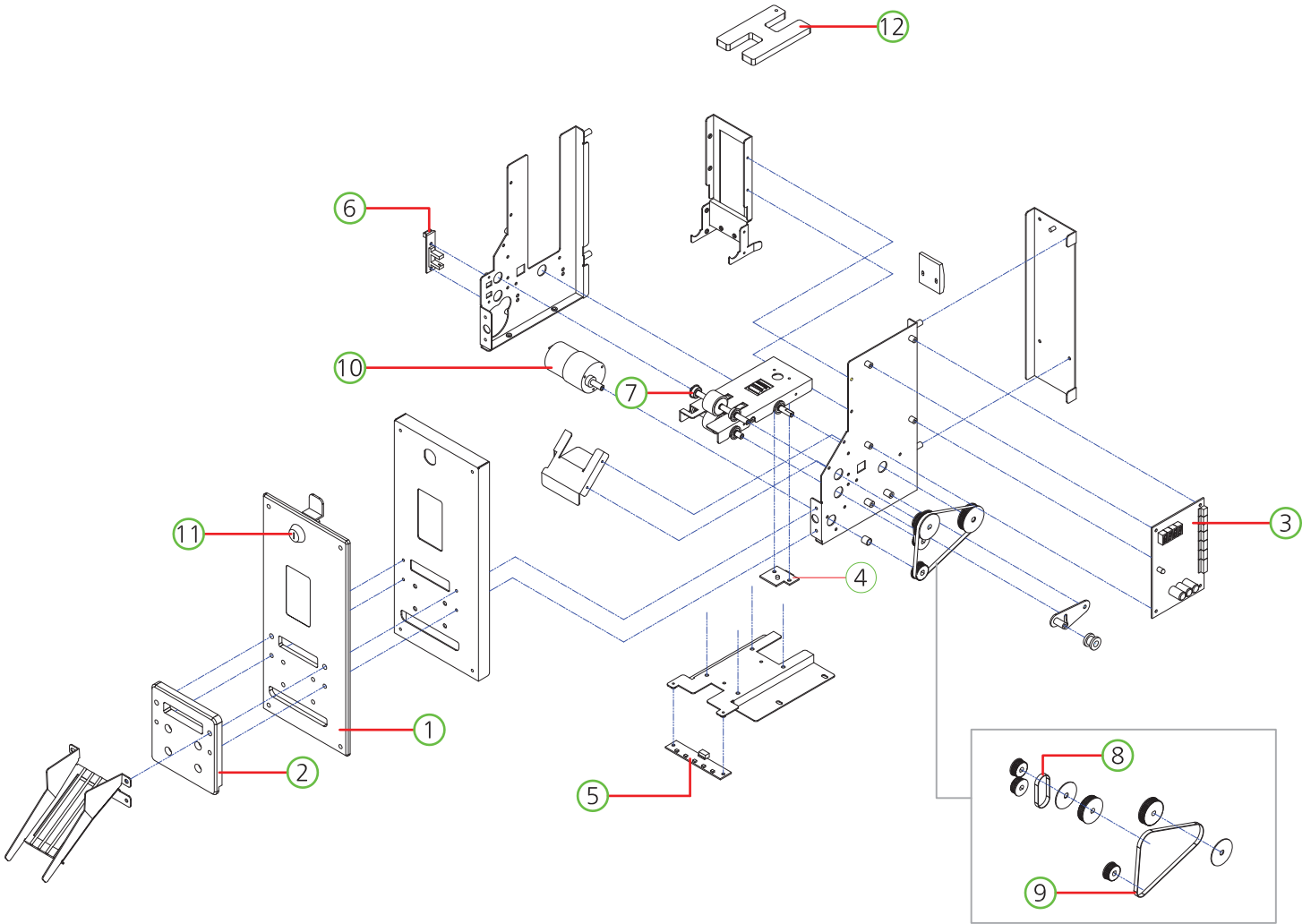

NO.	PART NAME	SPEC.	QUANTITY	CODE NO.
1	CARD DISPENSER FRONT COVER ACRYL	ACRYL-2.7t	1	MWWE0ACR066
2	CARD DISPENSER FRONT MASK	-	1	MDM30ACR040
3	CARD DISPENSER IO PCB ASS'Y	-	1	ASBP0PCB008
4	CARD IR SENSOR PCB ASS'Y	-	1	ASBP0PCB009
5	LED PCB ASS'Y	-	1	AMUM0PCB005
6	PHOTO INT1 (ANGLE) PCB ASS'Y	-	1	AZZZ0PCB103
7	BEARING	F686ZZ	1	MZZZ0BEA094
8	TIMMING BELT-A	52MXL, W4.8	1	MZZZ0BEL018
9	TIMMING BELT-B	147MXL, W4.8	1	MZZZ0BEL019
10	DC MOTOR	KGC-040-3429C	1	MZZZ0MOT089
11	KEY ASS'Y [ INT ]	7001	1	MZZZ0KEY076
	KEY ASS'Y [ CEC ]	CEC C581	1	MZZZ0KEY069
12	CARD HEAVY PUSH BKT	-	1	MSBP0MEP023



## 6-12. CARD DISPENSER COVER PART

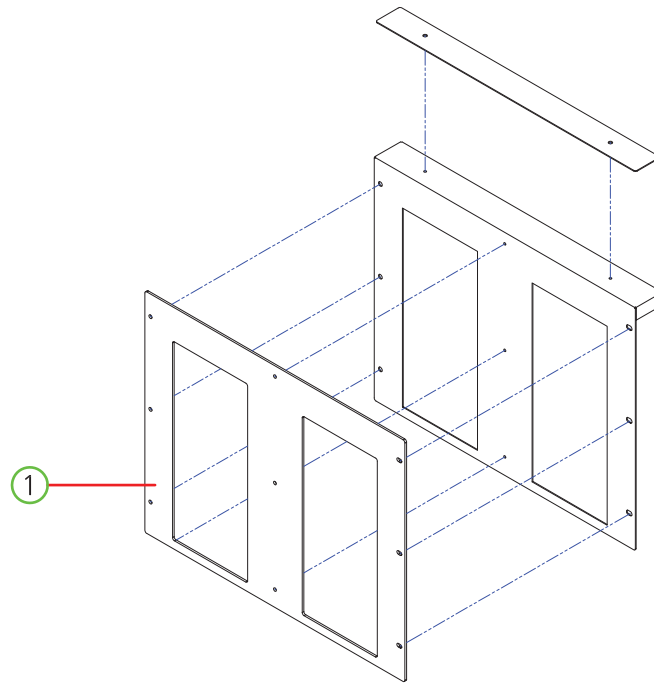

NO.	PART NAME	SPEC.	QUANTITY	CODE NO.
1	CARD DISPENSER COVER ACRYL	ACRYL-2.7t	1	MWWE0ACR019

## 6-13. CABINET MIDDLE REAR FRAME PART

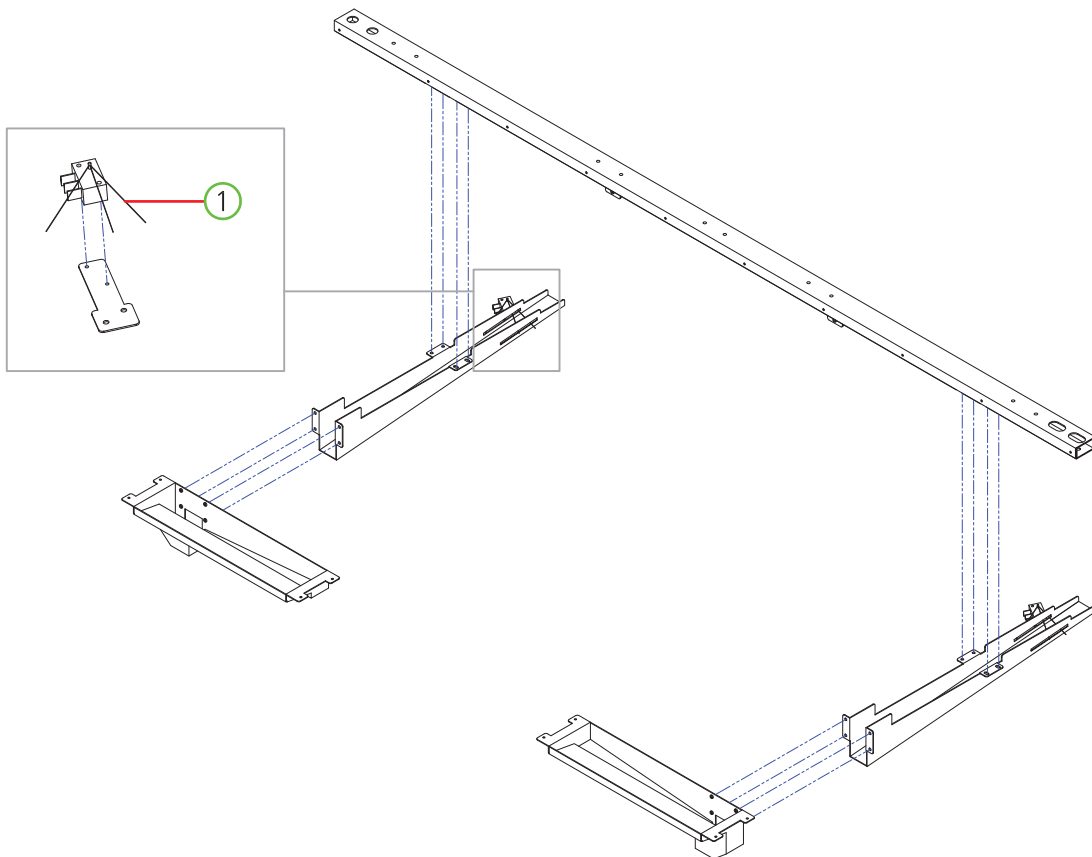

NO.	PART NAME	SPEC.	QUANTITY	CODE NO.
1	MICRO SWITCH	CNR-05H-03	1	MELE0MIC002

# 6-14. CARD CONVEYOR PART

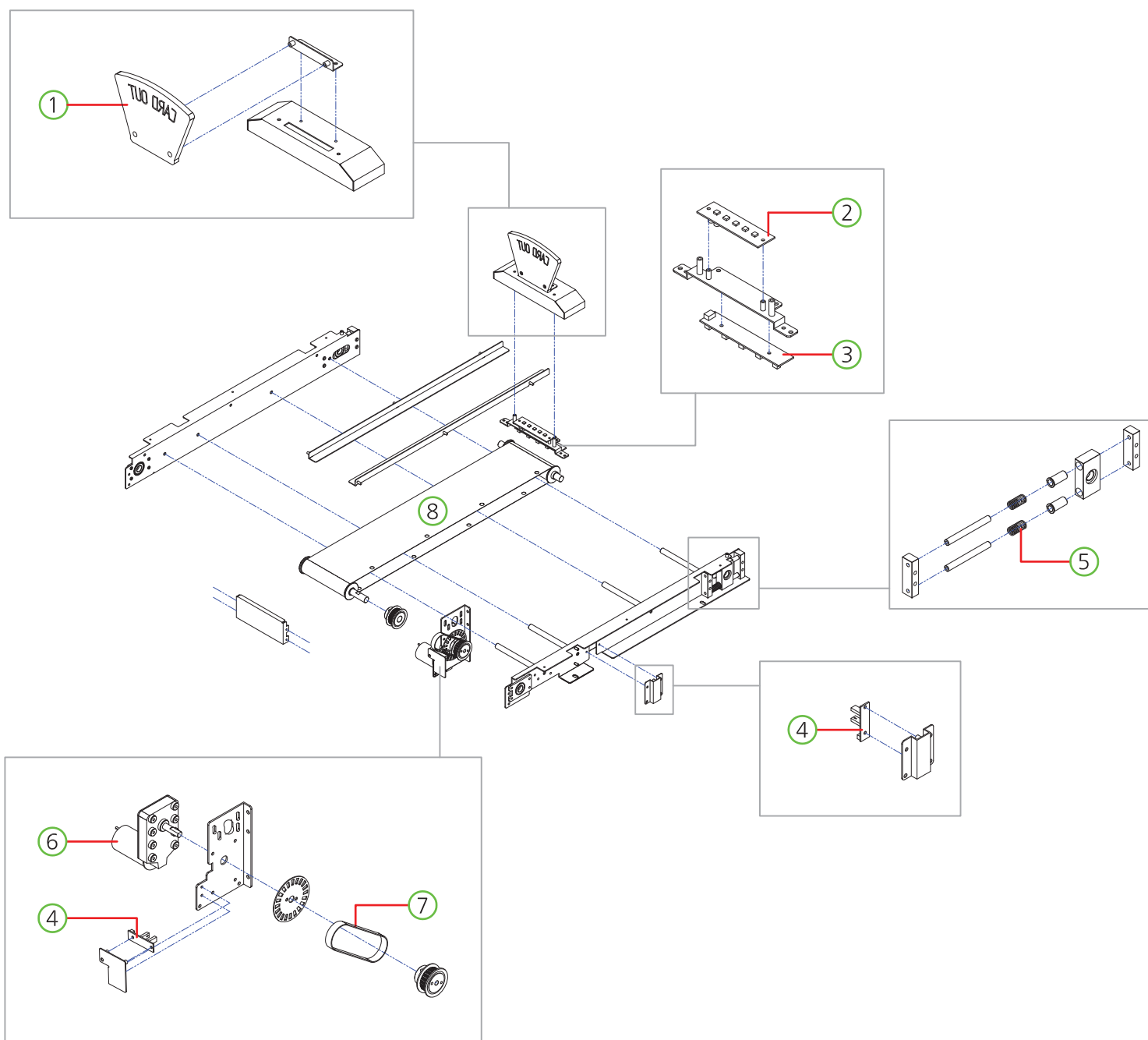

NO.	PART NAME	SPEC.	QUANTITY	CODE NO.
1	CARD OUT DISPLAY ACRYL	ACRYL-8.0t	1	MWWE0ACR036
2	CARD OUT LED PCB ASS'Y	-	1	AWWE0PCB002
3	CARD CHECK SENSOR PCB ASS'Y	-	1	ADM30PCB003
4	PHOTO-INT1 (ANGLE) PCB ASS'Y	-	2	AZZ0PCB103
5	CONVEYOR TENSION SPRING	SUS304-1.2t	4	MDM30SPR001
6	MOTOR	KGE-0182-ND3657U1 (12V,27rpm)	2	MZZ0MOT115
7	TIMMING BELT	100XL-037	4	MZZ0BEL036
8	CARD CONVEYOR BELT	URETHANE-0.8t	1	ADM30ASS003

# 6-15. MONITOR PLATE-L PART

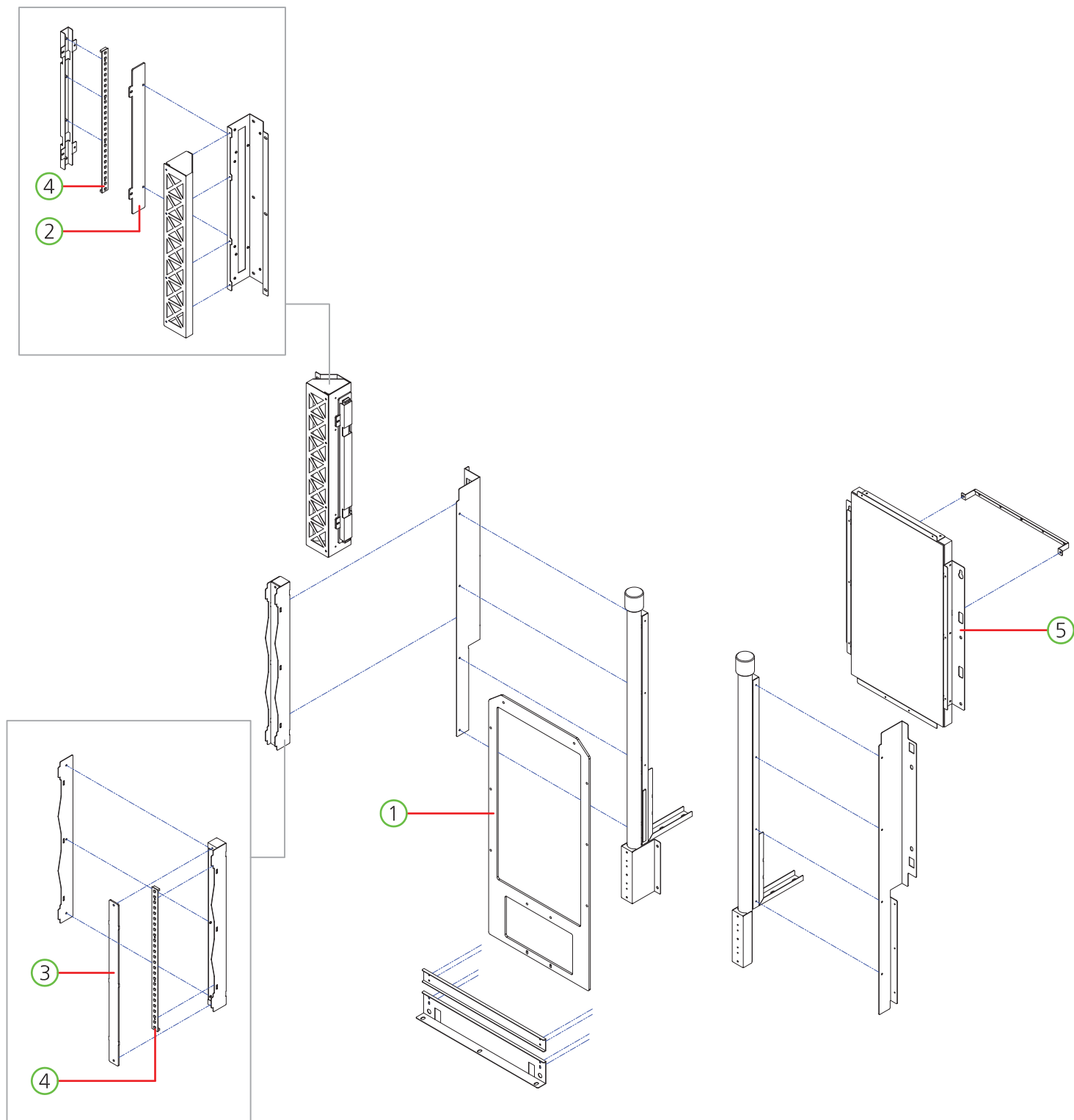

NO.	PART NAME	SPEC.	QUANTITY	CODE NO.
1	MONITOR BEZEL ACRYL	ACRYL-4.5t	1	MWWE0ACR037
2	SIDE DISPLAY LED COVER ACRYL	ACRYL-3.0t	1	MWWE0ACR038
3	MIDDLE PLATE FRONT LED PCB COVER ACRYL	ACRYL-3.0t	1	MWWE0ACR024
4	MIDDLE DISPLAY FRONT LED PCB ASS'Y	WB2813LED_26EA	1	AWWE0PCB003
5	MONITOR	-	1	MZZZ0LCD017

## 6-16. SIDE DISPLAY LOWER COVER BKT PART

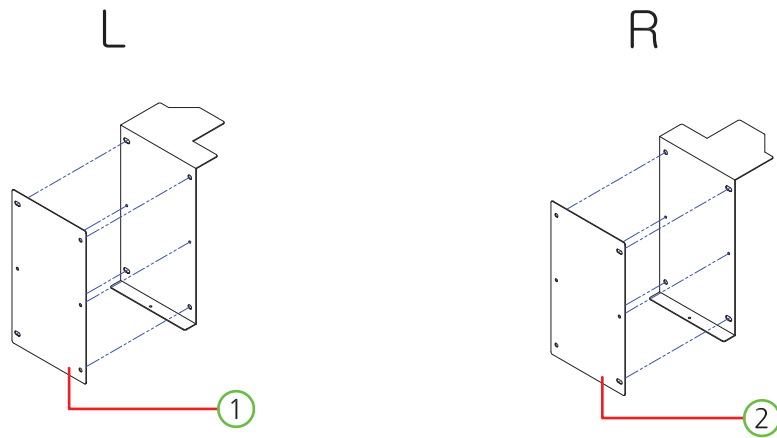

NO.	PART NAME	SPEC.	QUANTITY	CODE NO.
1	SIDE DISPLAY LOWER ACRYL-L	-	1	MWWE0ACR032
2	SIDE DISPLAY LOWER ACRYL-R	-	1	MWWE0ACR033

## 6-17. MONITOR PLATE LOWER COVER PART

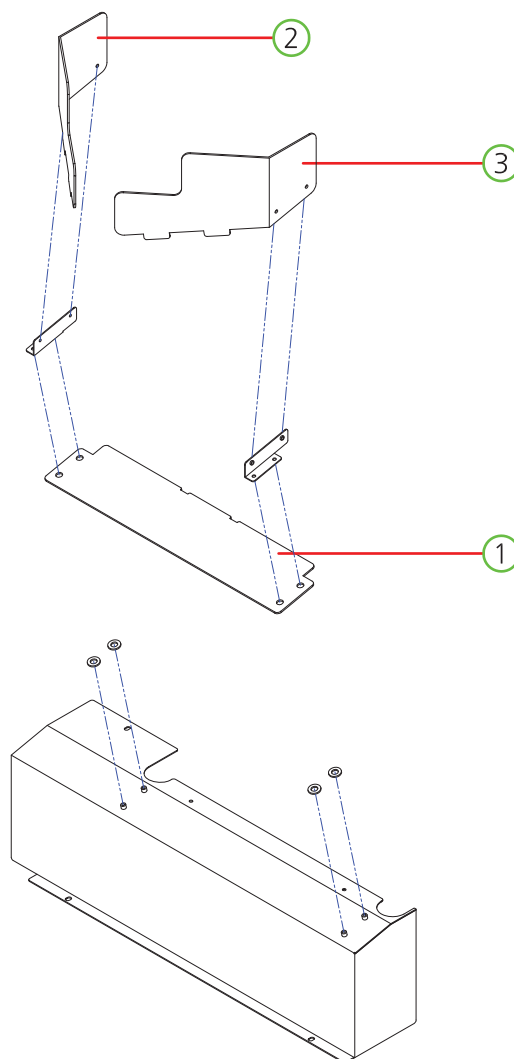

NO.	PART NAME	SPEC.	QUANTITY	CODE NO.
1	PIN BASE MIDDLE CUSHION ACRYL	PC-2.0t	1	MWWE0ACR029
2	PIN BASE SIDE FENCE ACRYL-L	PC-2.0t	1	MWWE0ACR030
3	PIN BASE SIDE FENCE ACRYL-R	PC-2.0t	1	MWWE0ACR031

## 6-18. FRONT UPPER DOOR PART

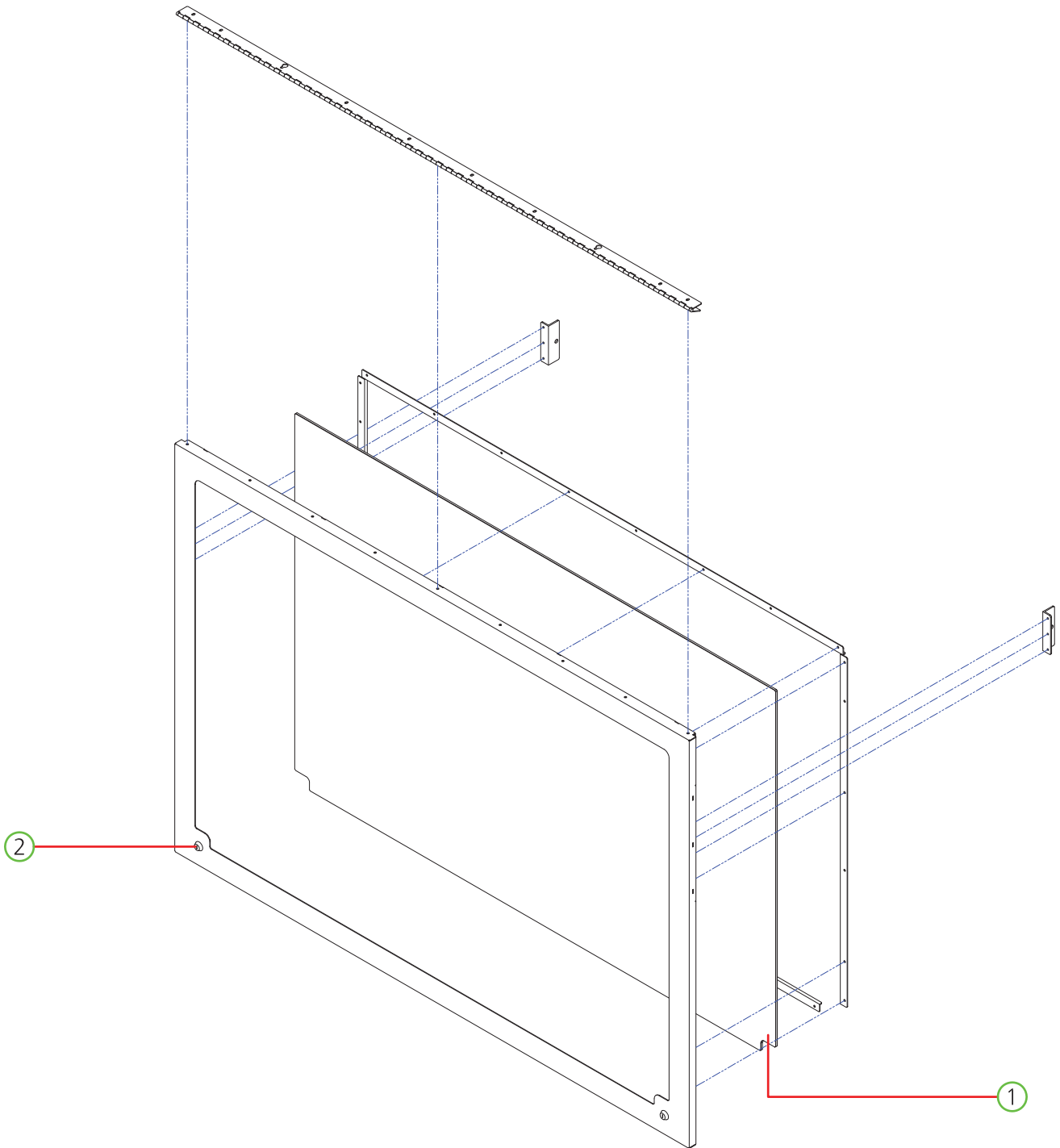

NO.	PART NAME	SPEC.	QUANTITY	CODE NO.
1	FRONT DOOR GLASS	GLASS-5t	1	MWWEOGLA001
2	KEY ASS'Y [ INT ]	7001	1	MZZZ0KEY076
	KEY ASS'Y [ CEC ]	CEC C581	1	MZZZ0KEY069

## 6-19. WOOFER SPEAKER PART

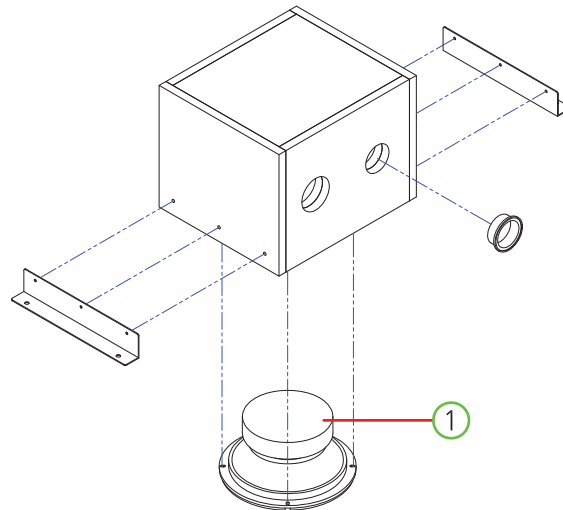

NO.	PART NAME	SPEC.	QUANTITY	CODE NO.
1	SPEAKER	8 INCH	1	MZZZ0SPE036

## 6-20. FRONT LOWER DOOR PART

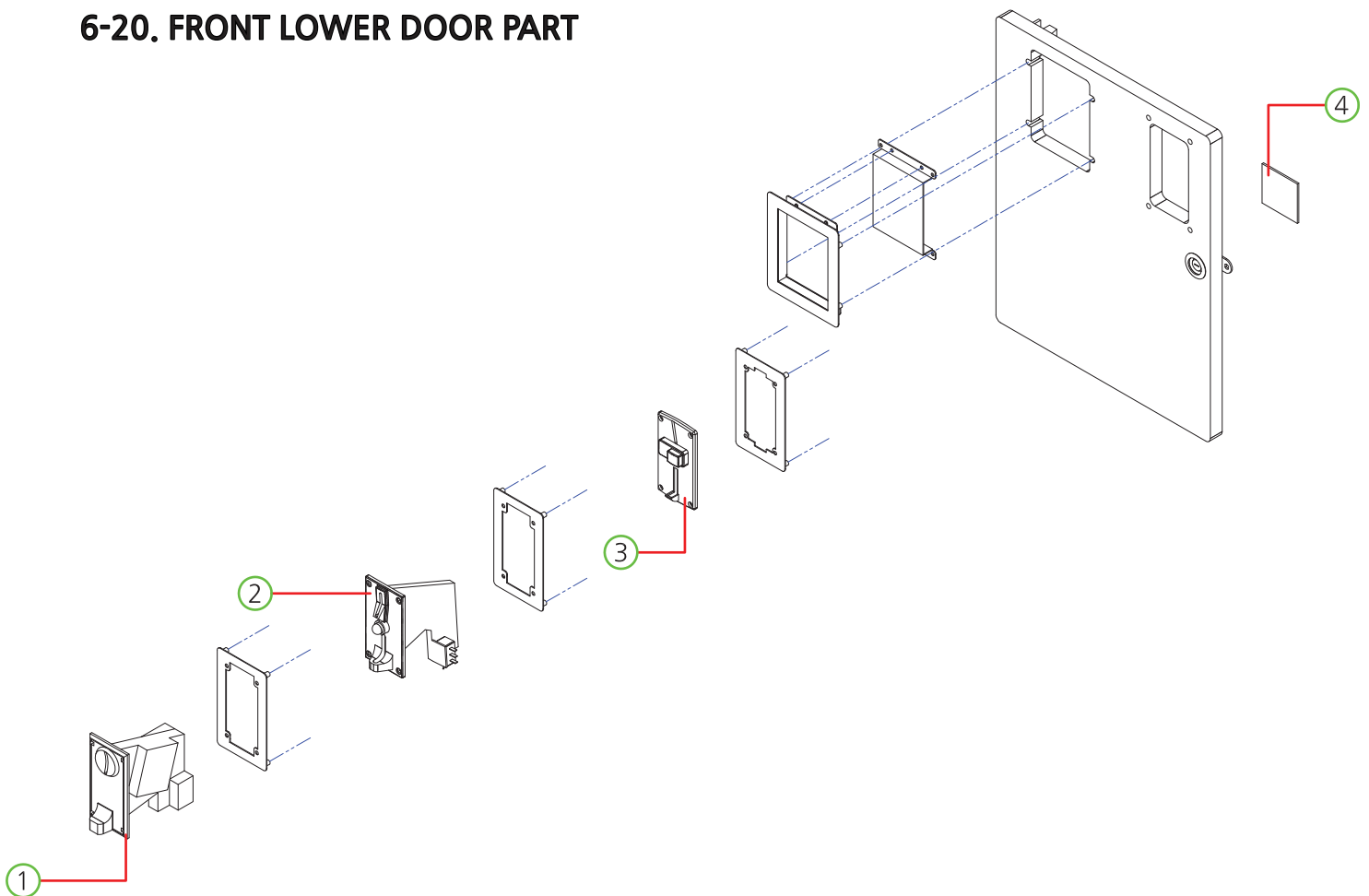

NO.	PART NAME	SPEC.	QUANTITY	CODE NO.
1	COIN SELECTOR [ INT ]	TW-389	1	MZZZ0COS052
2	COIN SELECTOR [ CEC ]	HS-03CS+SWITCH	1	MZZZ0COS028
3	COIN SELECTOR [ UK ]	RM5	1	MZZZ0COS049
4	COIN JOIN PCB ASS'Y	-	1	AZZZ0PCB137

## 6-21. TICKET DOOR PART

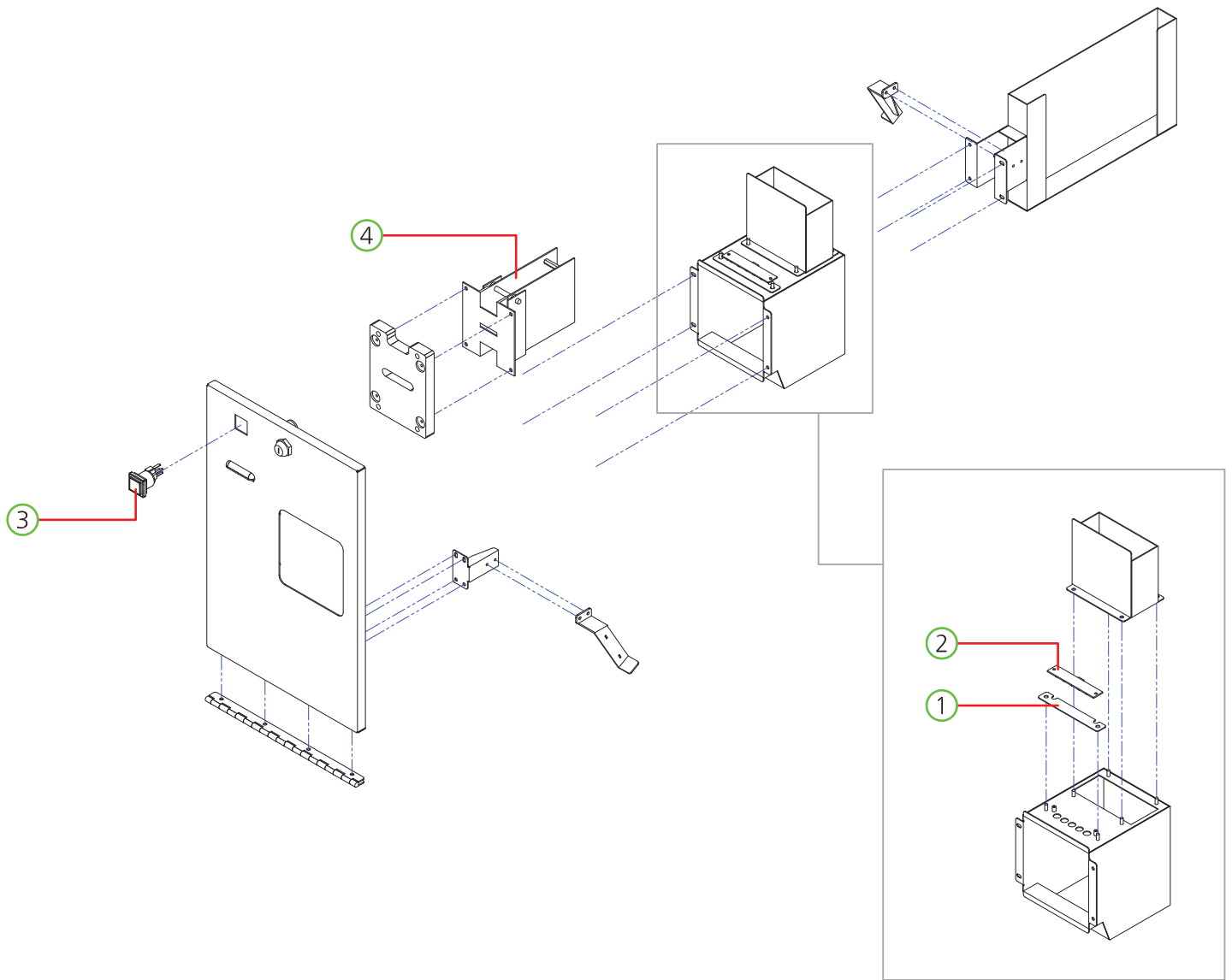

NO.	PART NAME	SPEC.	QUANTITY	CODE NO.
1	CARD OUT LED PCB COVER ACRYL	PET-1.0t	1	MWWE0ACR021
2	OUT LED PCB ASS'Y	-	1	ABAP0PCB003
3	BUTTON SWITCH	AMIPB-26HS-R12D	1	MMUM0BUT002
4	TICKET DISPENSOR	CLE CL-002Q_270 HIGH SPEED	1	MZZZ0TID010

## 6-22. SMPS PART

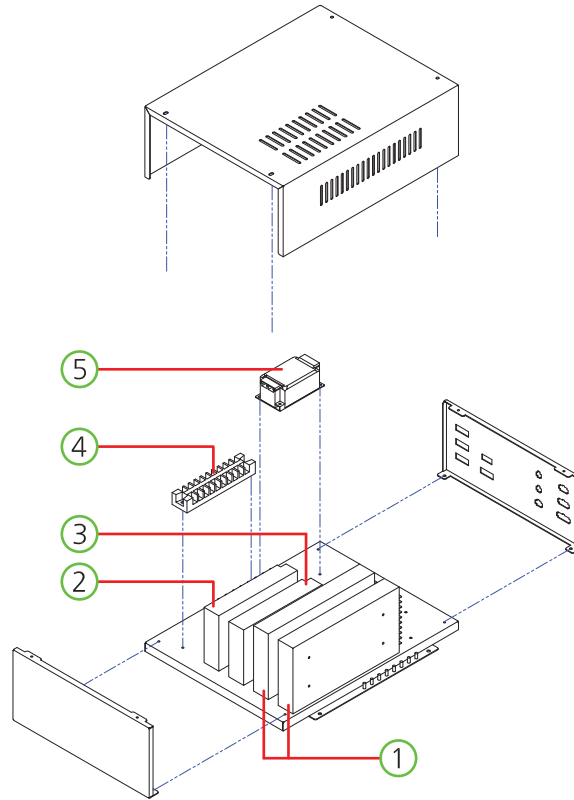

NO.	PART NAME	SPEC.	QUANTITY	CODE NO.
1	POWER SMPS	RSP-320-12	2	MELE0SMP109
2	POWER SMPS	LRS 150F_24 MW 24V6A	1	MELE0SMP085
3	POWER SMPS	LRS 150F_5	1	MELE0SMP096
4	TERMINAL BLOCK	250V 10P	1	MELE0TEB003
5	NOISE FILTER	RNS-2010	1	MELE0NOI009

## 6-23. MAIN BOARD PART

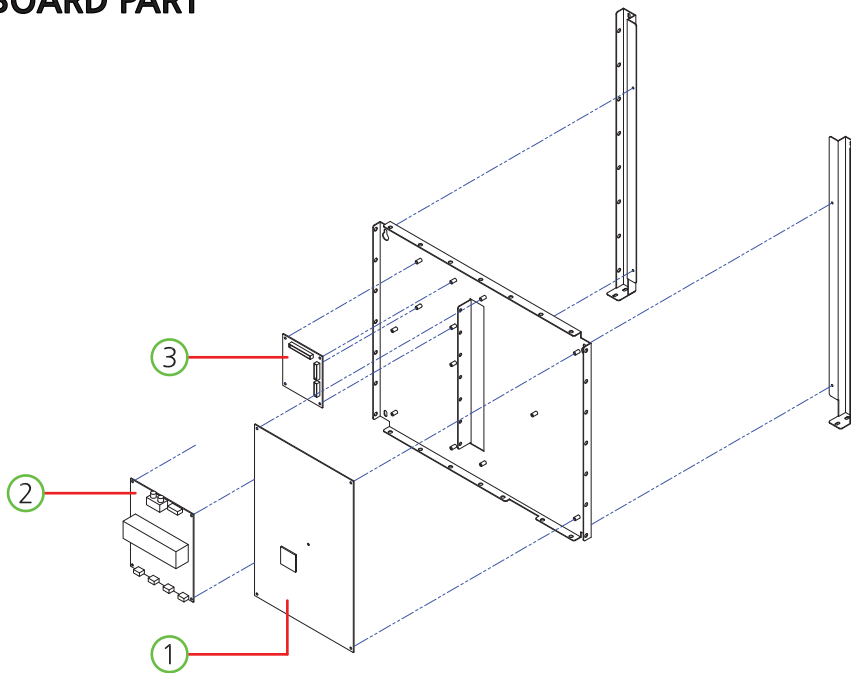

NO.	PART NAME	SPEC.	QUANTITY	CODE NO.
1	MAIN BOARD PCB ASS'Y	-	1	AWWE0PCB001
2	DIGITAL AMP PCB ASS'Y	2.1CH	1	APUJ0PCB002
3	WS2812B IO PCB ASS'Y	-	1	AZZZ0PCB152



## 6-24. AC INPUT PART

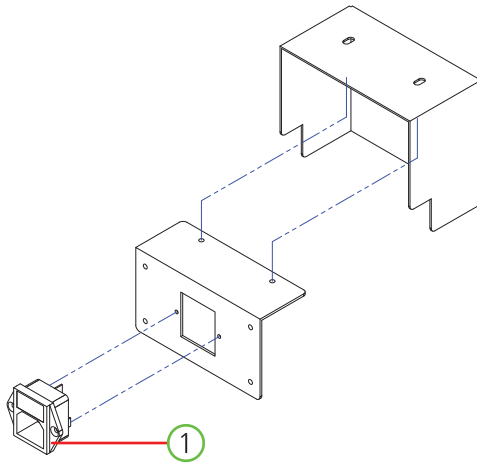

NO.	PART NAME	SPEC.	QUANTITY	CODE NO.
1	AC INPUT	DAC-13H	1	MELE0SWI015

## 6-25. CONTROL PANEL PART

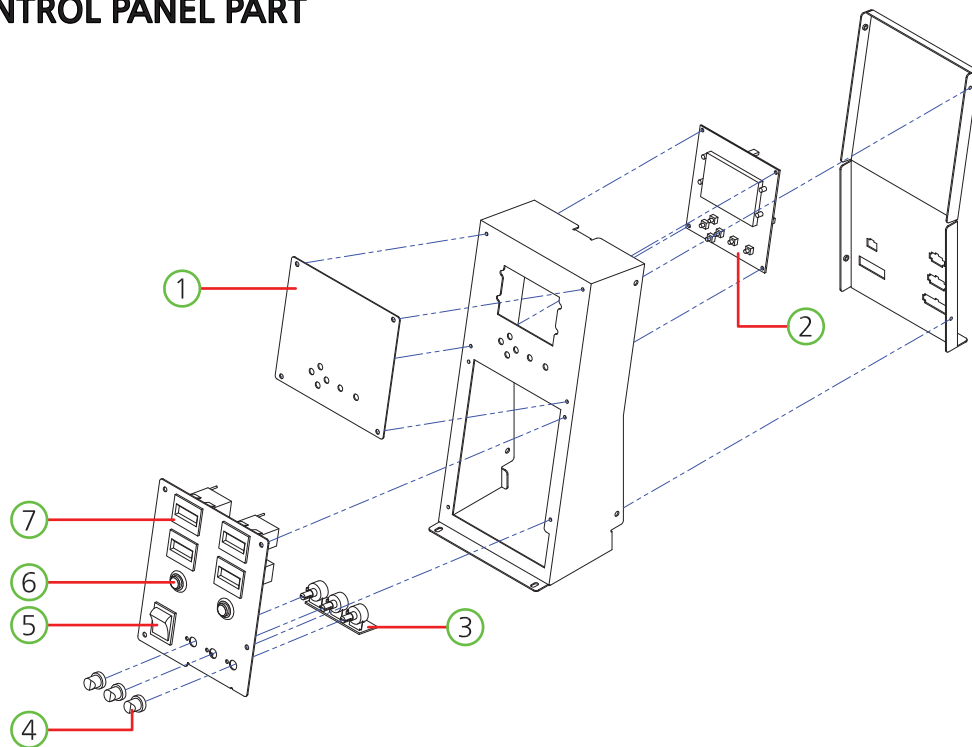

NO.	PART NAME	SPEC.	QUANTITY	CODE NO.
1	CONTROL PANEL COVER ACRYL	PET-1.0t	1	MWWE0ACR022
2	SETUP LCD PCB ASS'Y	2.1CH	1	AZZZ0PCB113
3	VOLUME PCB ASS'Y	3CH	1	APUJ0PCB005
4	VOLUME KNOB	-	3	MELE0VOL007
5	ROCKER SWITCH	T-125 4P	1	MELE0SWI004
6	PUSH BUTTON SWITCH	HS 412R	1	MELE0PUS006
7	COUNTER	OA127CL	1	MZZZ0COU002

# 7. PART PICTURE

- BILLBOARD PART

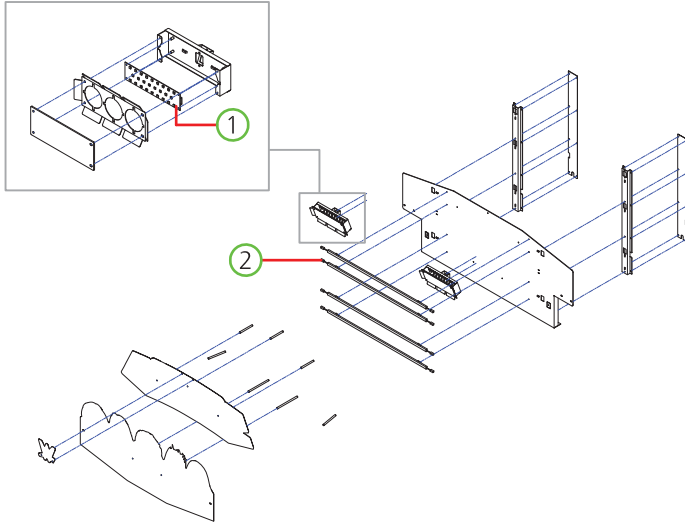

- SPEAKER PART

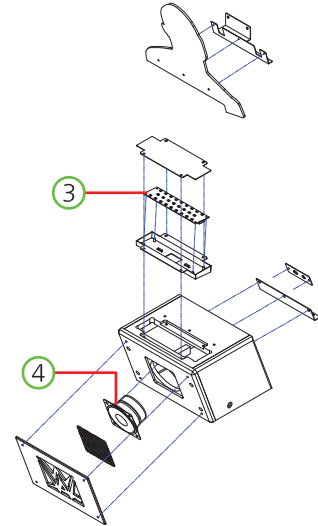

- BUTTON PANEL PART

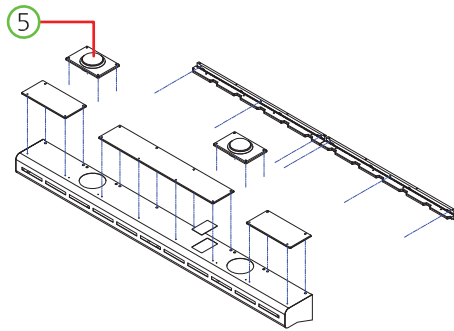

- BONUS DISPLAY PART

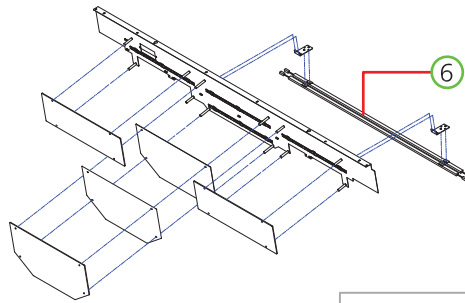

- BONUS TARGET PART

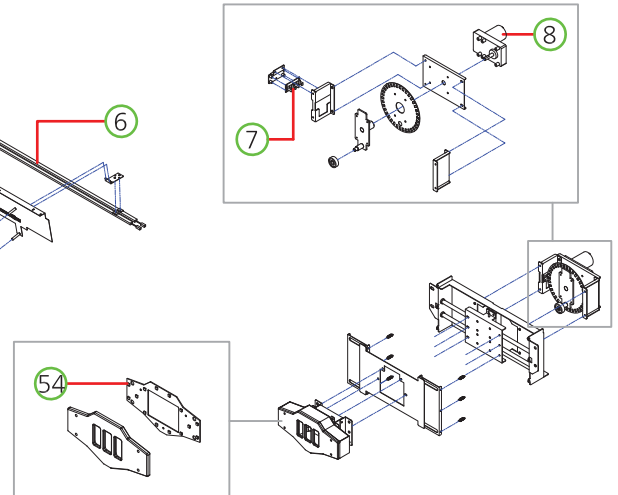

- PIN BASE PART

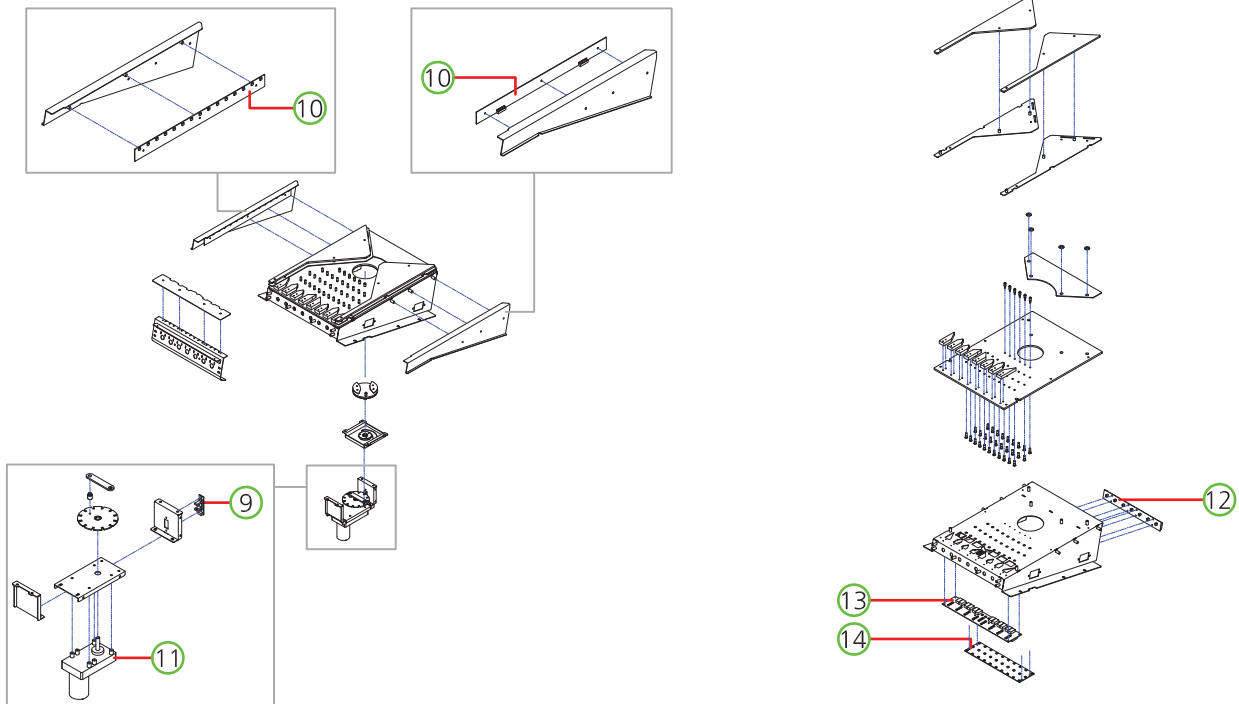

- BALL ELEVATOR RAIL PART

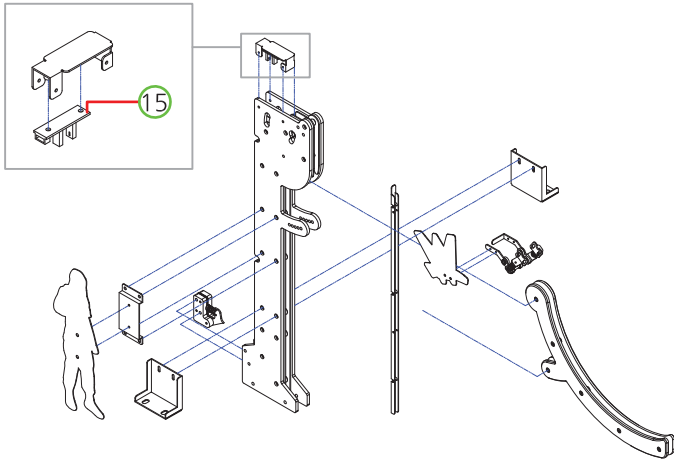

- BALL ELEVATOR BODY PART

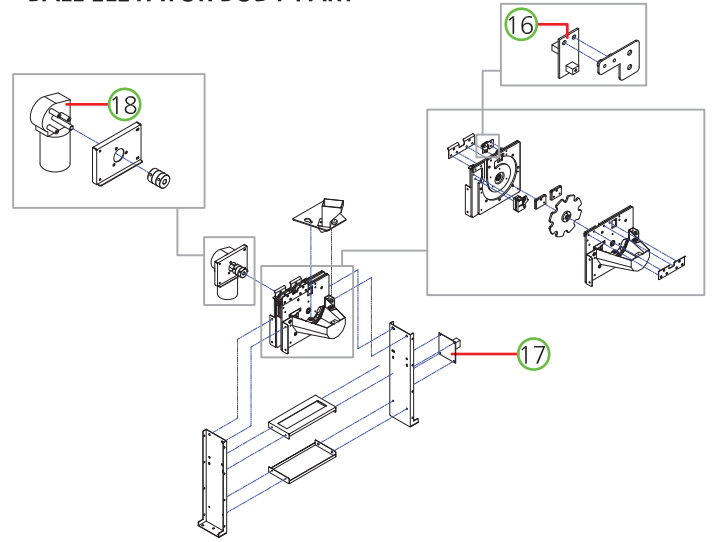

- CARD DISPENSER PART

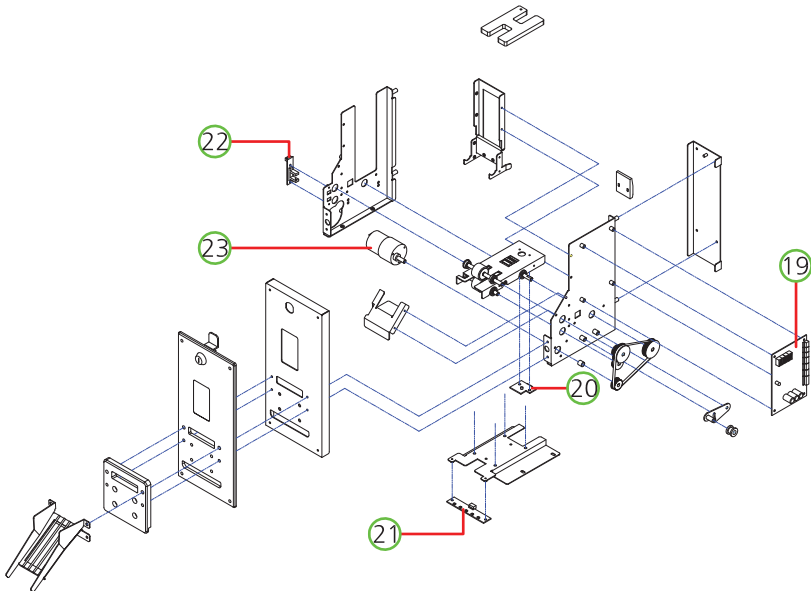

- CABINET MIDDLE REAR FRAME PART

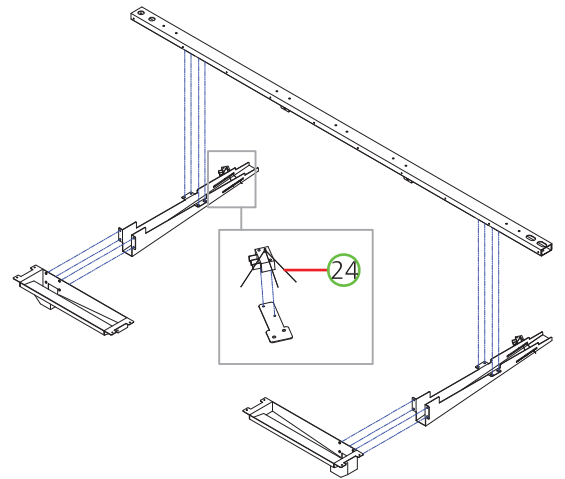

- CARD CONVEYOR PART

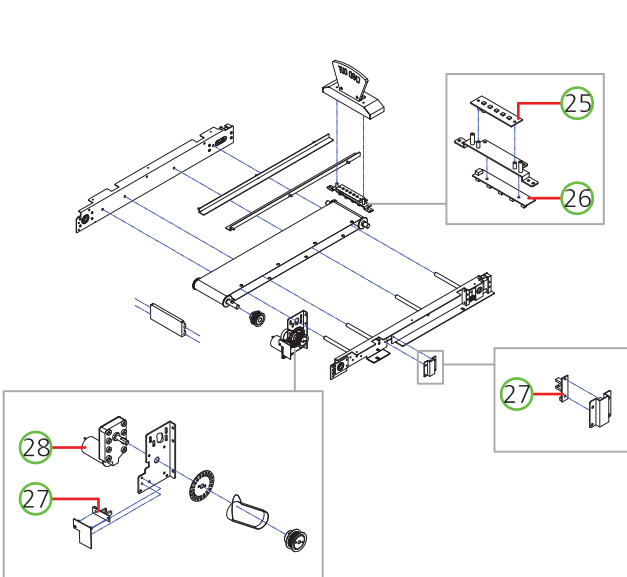

- MONITOR PLATE-L PART

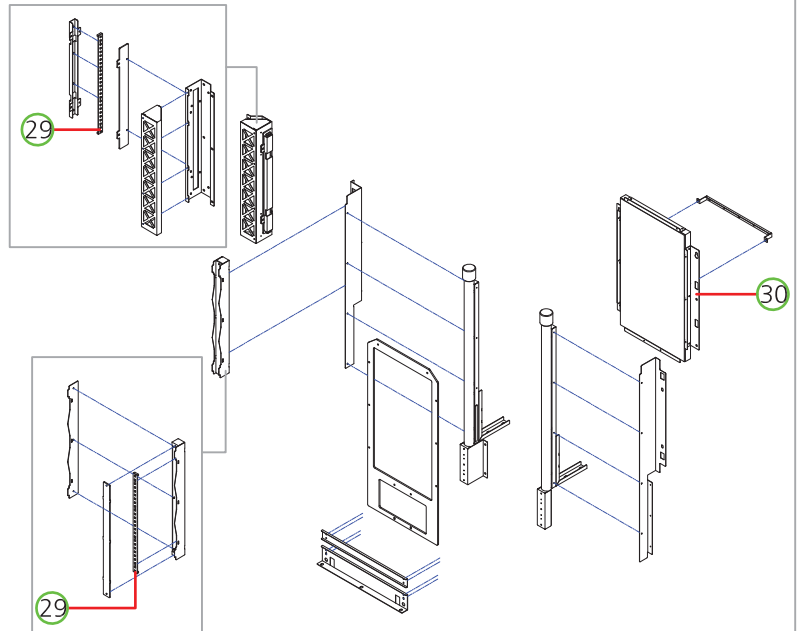

- WOOFER SPEAKER PART

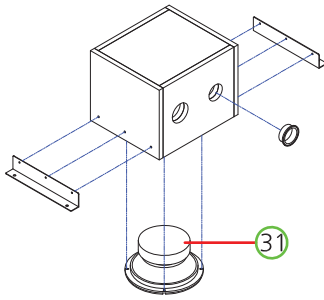

- FRONT LOWER DOOR PART

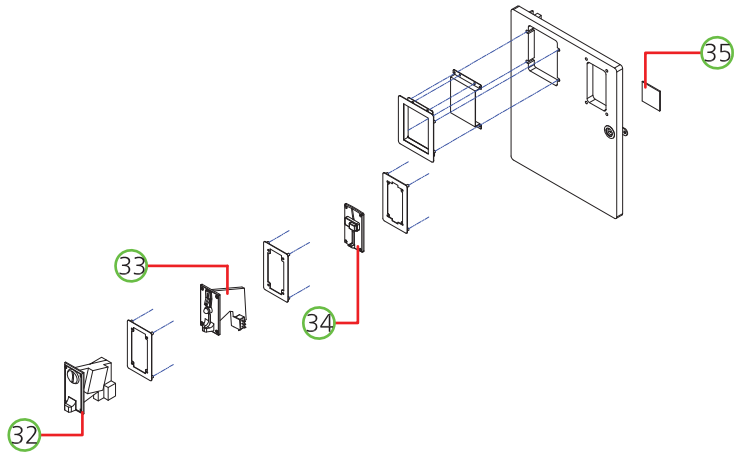

- TICKET DOOR PART

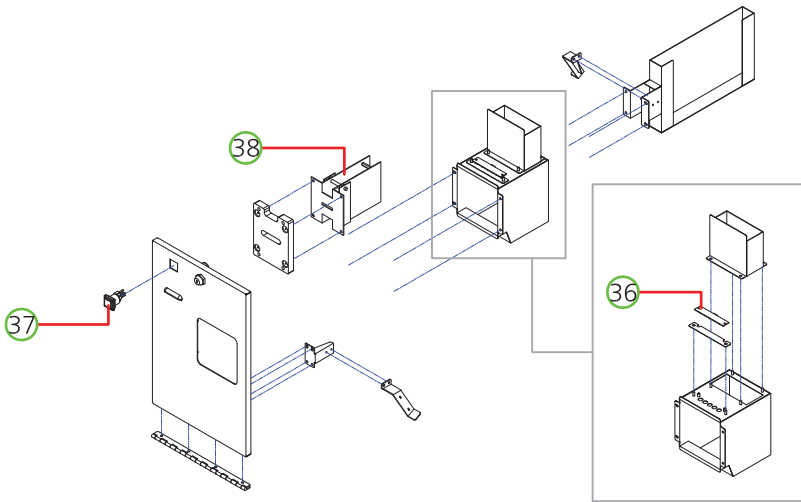

- SMPS PART

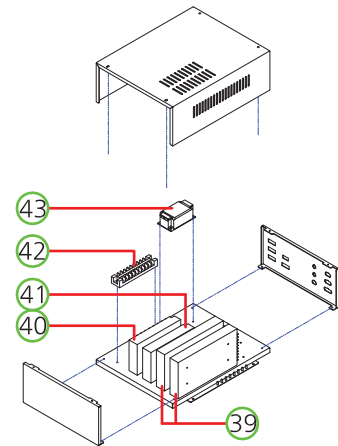

- MAIN BOARD PART

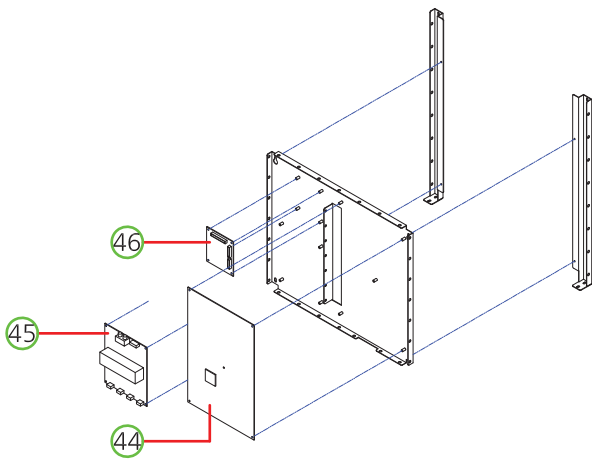

- AC INPUT PART

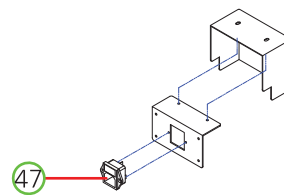



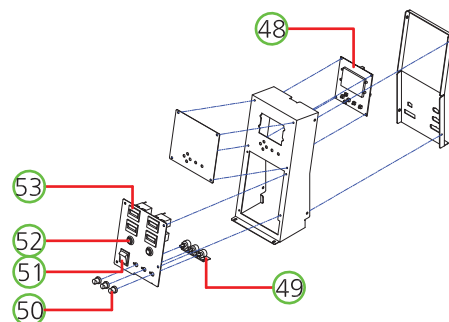



- CONTROL PANEL PART















NO.	PIC	PART NAME	SPEC.	QTY	CODE NO.	WARRANTY	
						6 Month	One Year
①	○	SPOT LED PCB ASS'Y	-	2	ABAP0PCB008		○
②	○	LED BAR 12V PCB ASS'Y	710mm	4	AZZZ0PCB165	N / A	N / A
③	○	SPOT LED PCB ASS'Y	-	1	ABAP0PCB008		○
④	○	SPEAKER	MID4.5+TW1/2"8Ω"	1	MZZZ0SPE021	N / A	N / A
⑤	○	BUTTON ASS'Y	CWB 401-WHITE COLOR (Ø100 DOME)_LED TYPE	2	MZZZ0BUT080	N / A	N / A
⑥	○	LED BAR 12V PCB ASS'Y	-	2	AZZZ0PCB128	N / A	N / A
⑦	○	PHOTO INT2 PCB ASS'Y	-	1	AWIW0PCB009		○
⑧	○	MOTOR	KGV-0120-ND3657 U1	1	MZZZ0MOT141	○	
⑨	○	PHOTO-INT1 (ANGLE) PCB ASS'Y	-	1	AZZZ0PCB103		○
⑩	○	PIN BASE SIDE LED PCB ASS'Y	-	2	AWWE0PCB004		○
⑪	○	MOTOR	KGV-0120-ND3657 U1	1	MZZZ0MOT141	○	
⑫	○	PIN CHECKER SENSOR PCB ASS'Y	-	1	AWWE0PCB006		○
⑬	○	PIN CHECKER FND PCB ASS'Y	-	1	AWWE0PCB007		○
⑭	○	PIN BASE LED PCB ASS'Y	-	1	AGHP0PCB019		○
⑮	○	PHOTO-INT1 (ANGLE) PCB ASS'Y	ANGLE TYPE	1	AZZZ0PCB103		○
⑯	○	ELEVATOR DISK SENSOR PCB ASS'Y	-	1	AGHP0PCB020		○
⑰	○	L6205 HOPPER PCB ASS'Y	-	1	AZZZ0PCB141		○
⑱	○	MOTOR	HSW6-5012A, DC12V, 50W, 33RPM	1	MZZZ0MOT118	○	
⑲	○	CARD DISPENSER IO PCB ASS'Y	-	1	ASBP0PCB008		○
⑳	○	CARD IR SENSOR PCB ASS'Y	-	1	ASBP0PCB009		○
㉑	○	LED PCB ASS'Y	-	1	AMUM0PCB005		○
㉒	○	PHOTO INT1 (ANGLE) PCB ASS'Y	-	1	AZZZ0PCB103		○
㉓	○	DC MOTOR	KGC-040-3429C	1	MZZZ0MOT089	○	
㉔	○	MICRO SWITCH	CNR-05H-03	1	MELE0MIC002	N / A	N / A
㉕	○	CARD OUT LED PCB ASS'Y	-	1	AWWE0PCB002		○
㉖	○	CARD CHECK SENSOR PCB ASS'Y	-	1	ADM30PCB003		○
㉗	○	PHOTO-INT1 (ANGLE) PCB ASS'Y	-	1	AZZZ0PCB103		○
㉘	○	MOTOR	KGE-0182-ND3657U1 (12V,27rpm)	2	MZZZ0MOT115	○	
㉙	○	MIDDLE DISPLAY FRONT LED PCB ASS'Y	WB2813LED_26EA	1	AWWE0PCB003		○
㉚	○	MONITOR	-	1	MZZZ0LCD017	N / A	N / A
㉛	○	SPEAKER	8 INCH	1	MZZZ0SPE036	N / A	N / A
㉜	○	COIN SELECTOR [ INT ]	TW-389	1	MZZZ0COS052	N / A	N / A
㉝	○	COIN SELECTOR [ CEC ]	HS-03CS+SWITCH	1	MZZZ0COS028	N / A	N / A
㉞	○	COIN SELECTOR [ UK ]	RM5	1	MZZZ0COS049	N / A	N / A
㉟	○	COIN JOIN PCB ASS'Y	-	1	AZZZ0PCB137		○
㊱	○	OUT LED PCB ASS'Y	-	1	ABAP0PCB003		○
㊲	○	BUTTON SWITCH	AMIPB-26HS-R12D	1	MMUM0BUT002	N / A	N / A
㊳	○	TICKET DISPENSOR	CLE CL-002Q_ 270 HIGH SPEED	1	MZZZ0TID010	N / A	N / A
㊴	○	POWER SMPS	RSP-320-12	2	MELE0SMP109		○
㊵	○	POWER SMPS	LRS 150F_24 MW 24V6A	1	MELE0SMP085		○





NO.	PIC	PART NAME	SPEC.	QTY	CODE NO.	WARRANTY	
						6 Month	One Year
41	○	POWER SMPS	LRS 150F_5	1	MELE0SMP096		○
42	○	TERMINAL BLOCK	250V 10P	1	MELE0TEB003	N / A	N / A
43	○	NOISE FILTER	RNS-2010	1	MELE0NOI009	N / A	N / A
44	○	MAIN BOARD PCB ASS'Y	-	1	AWWE0PCB001		○
45	○	DIGITAL AMP PCB ASS'Y	2.1CH	1	APUJ0PCB002		○
46	○	WS2812B IO PCB ASS'Y	-	1	AZZZ0PCB152		○
47	○	AC INPUT	DAC-13H	1	MELE0SWI015	N / A	N / A
48	○	SETUP LCD PCB ASS'Y	2.1CH	1	AZZZ0PCB113		○
49	○	VOLUME PCB ASS'Y	3CH	1	APUJ0PCB005		○
50	○	VOLUME KNOB	-	3	MELE0VOL007	N / A	N / A
51	○	ROCKER SWITCH	T-125 4P	1	MELE0SWI004	N / A	N / A
52	○	PUSH BUTTON SWITCH	HS 412R	1	MELE0PUS006	N / A	N / A
53	○	COUNTER	OA127CL	1	MZZZ0COU002	N / A	N / A
54	○	BONUS TARGET SENSOR PCB ASS'Y	-	1	AWWE0PCB005		○





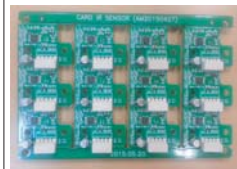

1	2	3	4	5	6
					
ABAP0PCB008	AZZZ0PCB165	ABAP0PCB008	MZZZ0SPE021	MZZZ0BUT080	AZZZ0PCB128



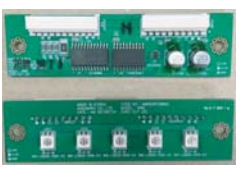



7	8	9	10	11	12
					
AWIW0PCB009	MZZZ0MOT141	AZZZ0PCB103	AWWE0PCB004	MZZZ0MOT141	AWWE0PCB006







13	14	15	16	17	18
					
AWWE0PCB007	AGHP0PCB019	AZZZ0PCB103	AGHP0PCB020	AZZZ0PCB141	MZZZ0MOT118

19	20	21	22	23	24
					
ASBP0PCB008	ASBP0PCB009	AMUM0PCB005	AZZZ0PCB103	MZZZ0MOT089	MELE0MIC002

25	26	27	28	29	30
					
AWWE0PCB002	ADM30PCB003	AZZZ0PCB103	MZZZ0MOT115	AWWE0PCB003	MZZZ0LCD017

31	32	33	34	35	36
					
MZZZ0SPE036	MZZZ0COS052	MZZZ0COS028	MZZZ0COS049	AZZZ0PCB137	ABAP0PCB003

37	38	39	40	41	42
					
MMUM0BUT002	MZZZ0TID010	MELE0SMP109	MELE0SMP085	MELE0SMP096	MELE0TEB003

43	44	45	46	47	48
					
MELE0NOI009	AWWE0PCB001	APUJ0PCB002	AZZZ0PCB152	MELE0SWI015	AZZZ0PCB113

49	50	51	52	53	54
					
APUJ0PCB005	MELE0VOL007	MELE0SWI004	MELE0PUS006	MZZZ0COU002	AWWE0PCB005



# HOW TO ADJUST THE GAP OF CARD DISPENSER

1

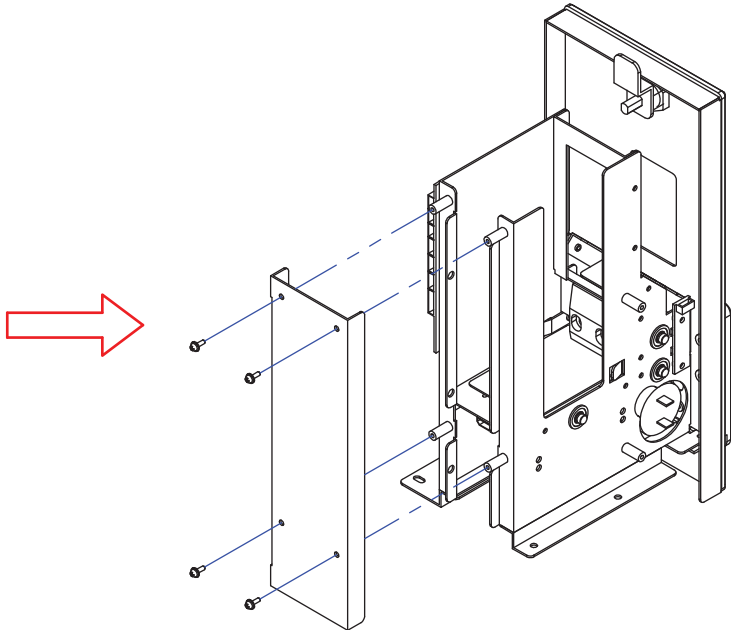
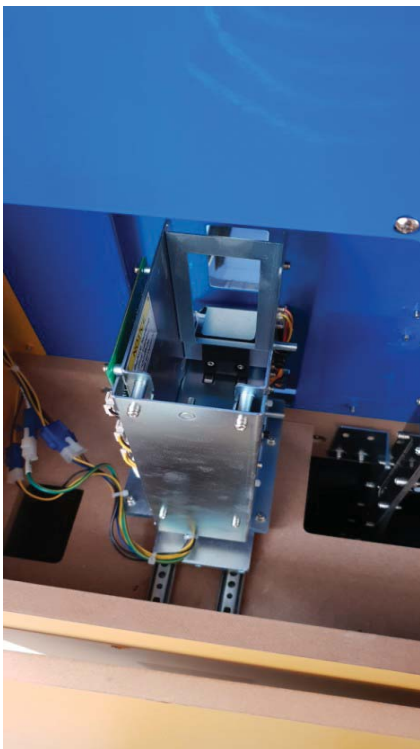

- Open upper door of back side of the machine and disassemble the metal part back side of card dispenser as a picture. [Bolt 4ea]

2

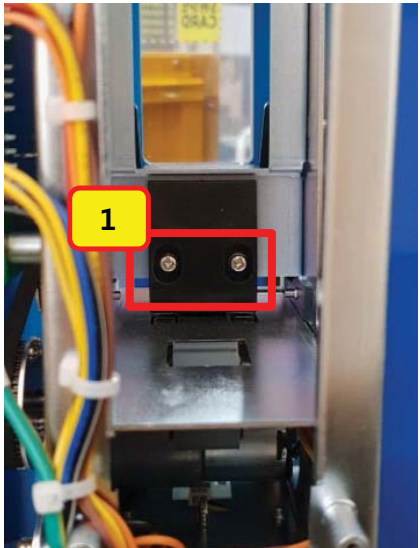

- Unlock little bit of fix bolt 2ea at No.1.

3



- Prepare CARD SETTING JIG as a picture.

4

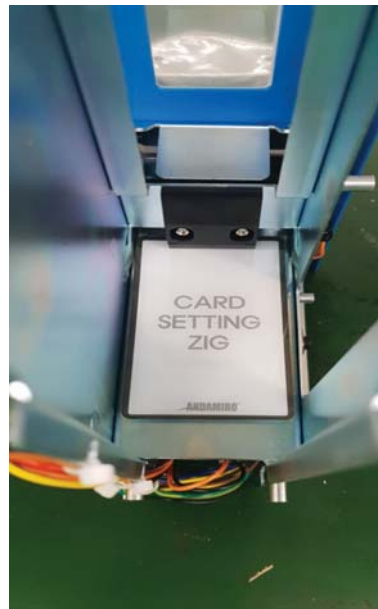
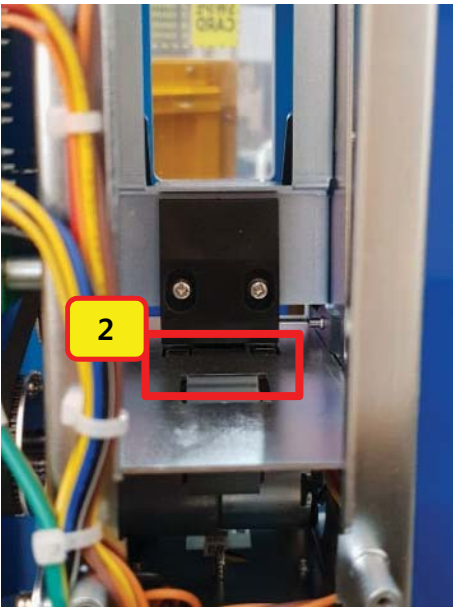

- Set CARD SETTING JIG to No.2 place. (lower side of black acrylic)  
[Refer to the right picture]

5

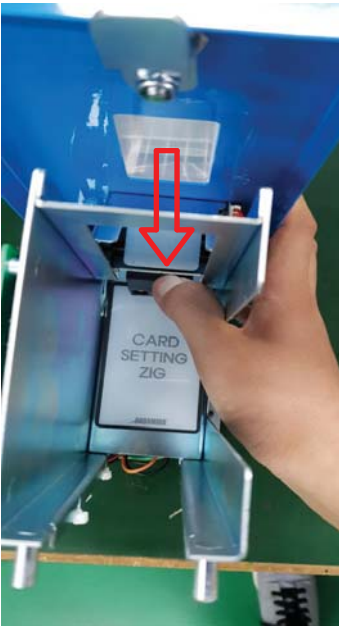

- Lock the bolt of section 2 pressing the upper side of black acrylic.  
After fixing, remove the card.

6

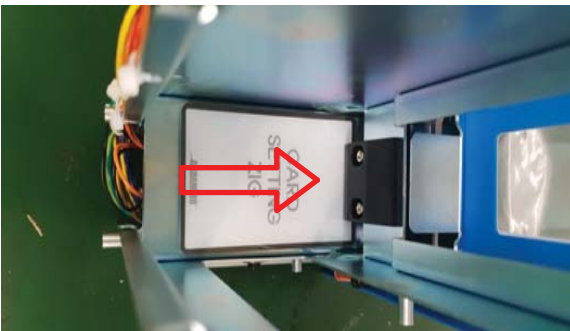

- Check if it is tight when you try to insert the CARD SETTING JIG again as left picture.  
If it is easy to insert or impossible to insert, go back to section 2 and work again.

- Gap between the arrows of left picture (No.2 of section 4)  
Allowable value: 1.1~1.3 mm  
Thickness of normal card: 0.8 mm

7

- After processing until section 6, run operation test.  
TEST MODE -> No. 7 CARD OUT TEST

MARK	DATE	REVISION

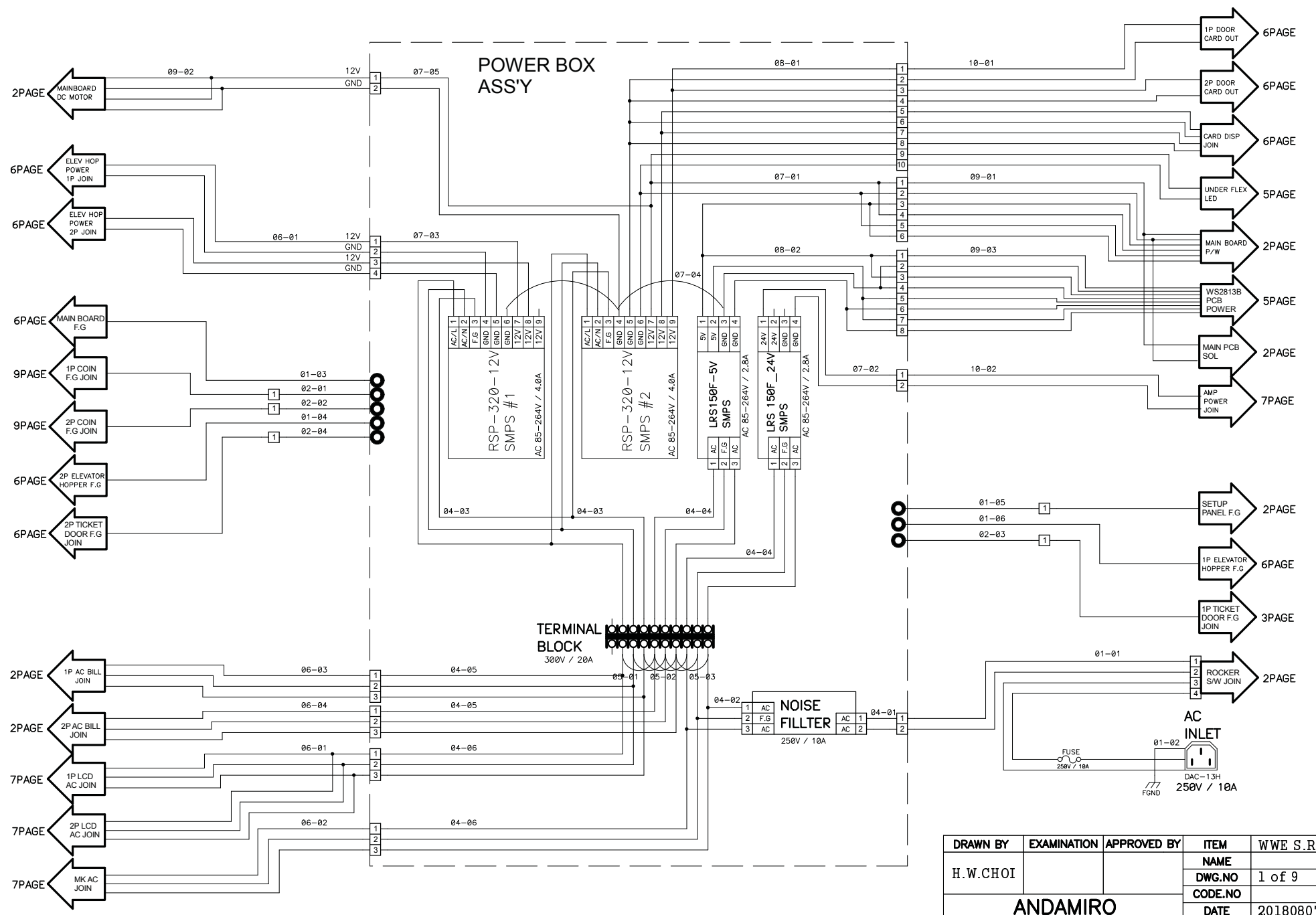

DRAWN BY	EXAMINATION	APPROVED BY	ITEM NAME	WWE S.R.
H.W.CHOI			DWG.NO	1 of 9
<b>ANDAMIRO</b>			CODE.NO	
			DATE	20180807

MARK	DATE	REVISION

# MAIN PCB 1/4

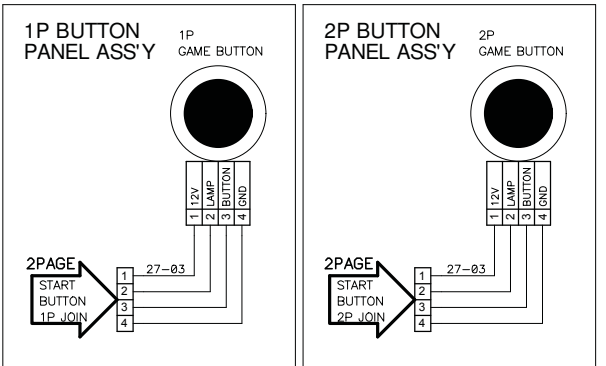
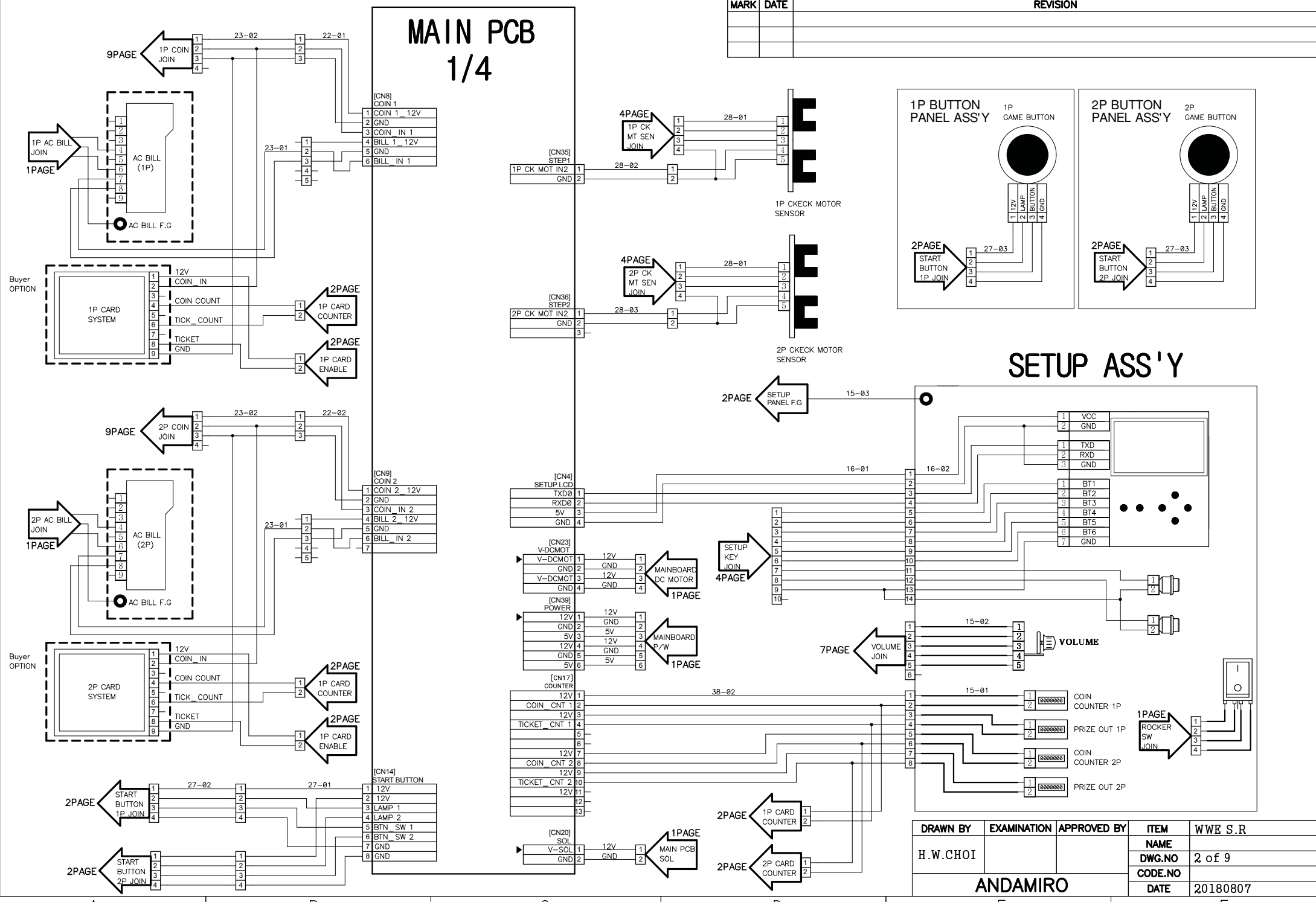

# SETUP ASS'Y

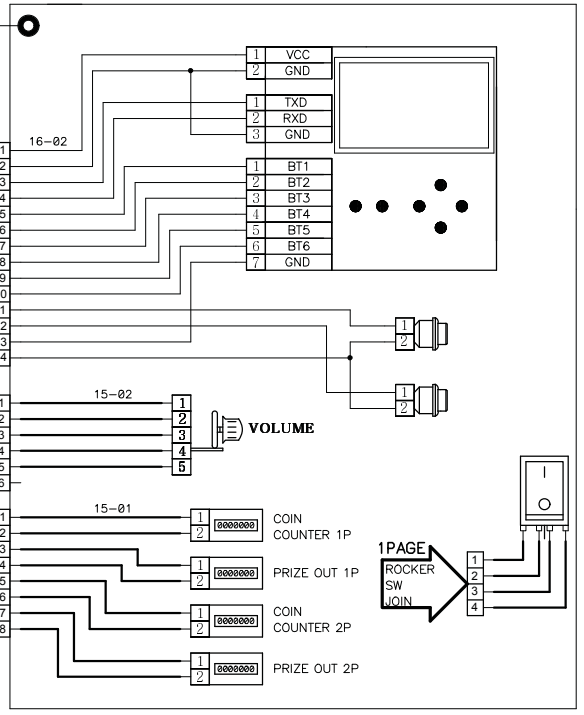

DRAWN BY	EXAMINATION	APPROVED BY	ITEM	WWE S.R
H.W.CHOI			NAME	
			DWG.NO	2 of 9
			CODE.NO	
			DATE	20180807

ANDAMIRO

MARK	DATE	REVISION

# MAIN PCB 2/4

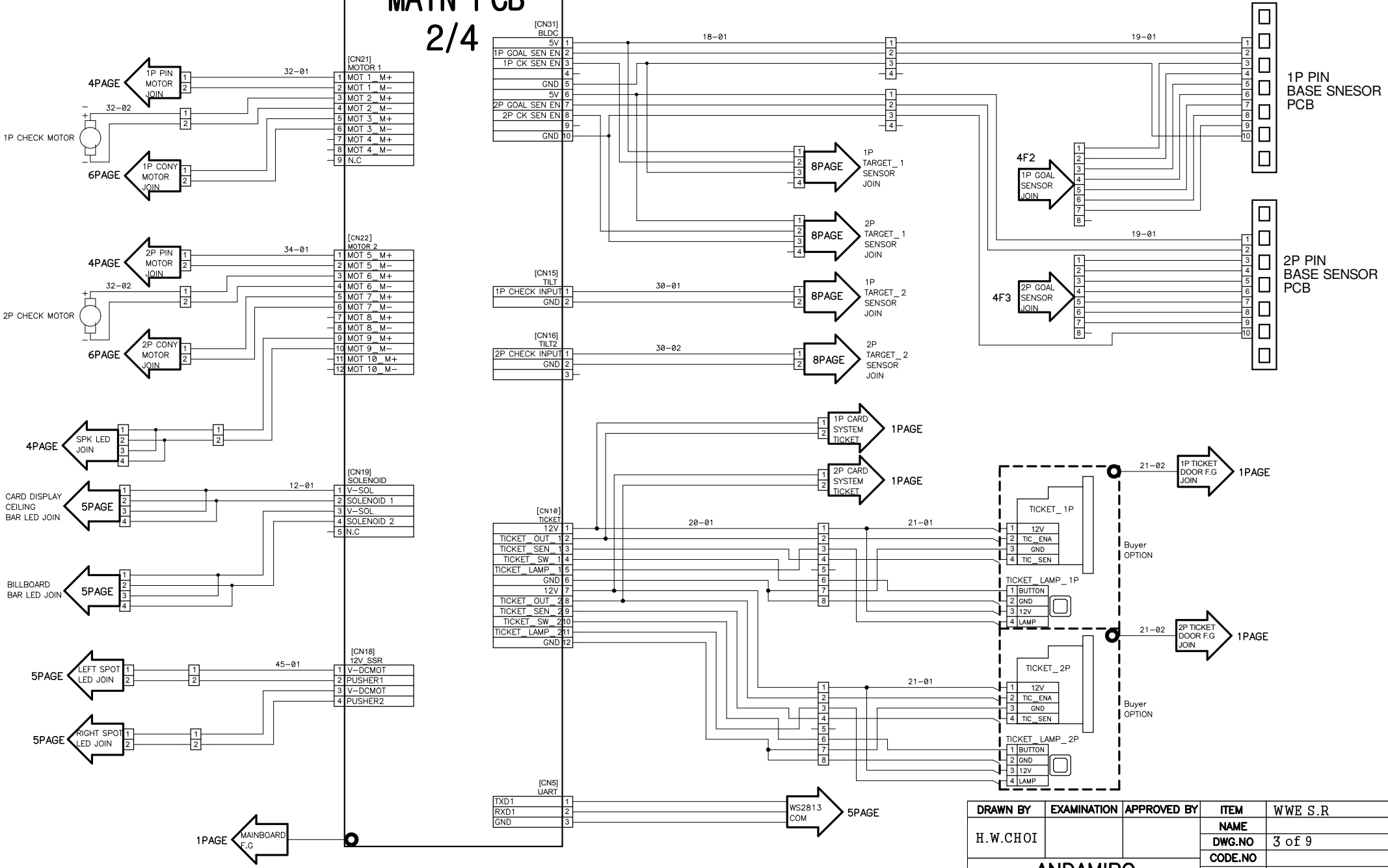

DRAWN BY	EXAMINATION	APPROVED BY	ITEM	WWE S.R
H.W.CHOI			NAME	
			DWG.NO	3 of 9
			CODE.NO	
			DATE	20180807

**ANDAMIRO**

MARK	DATE	REVISION

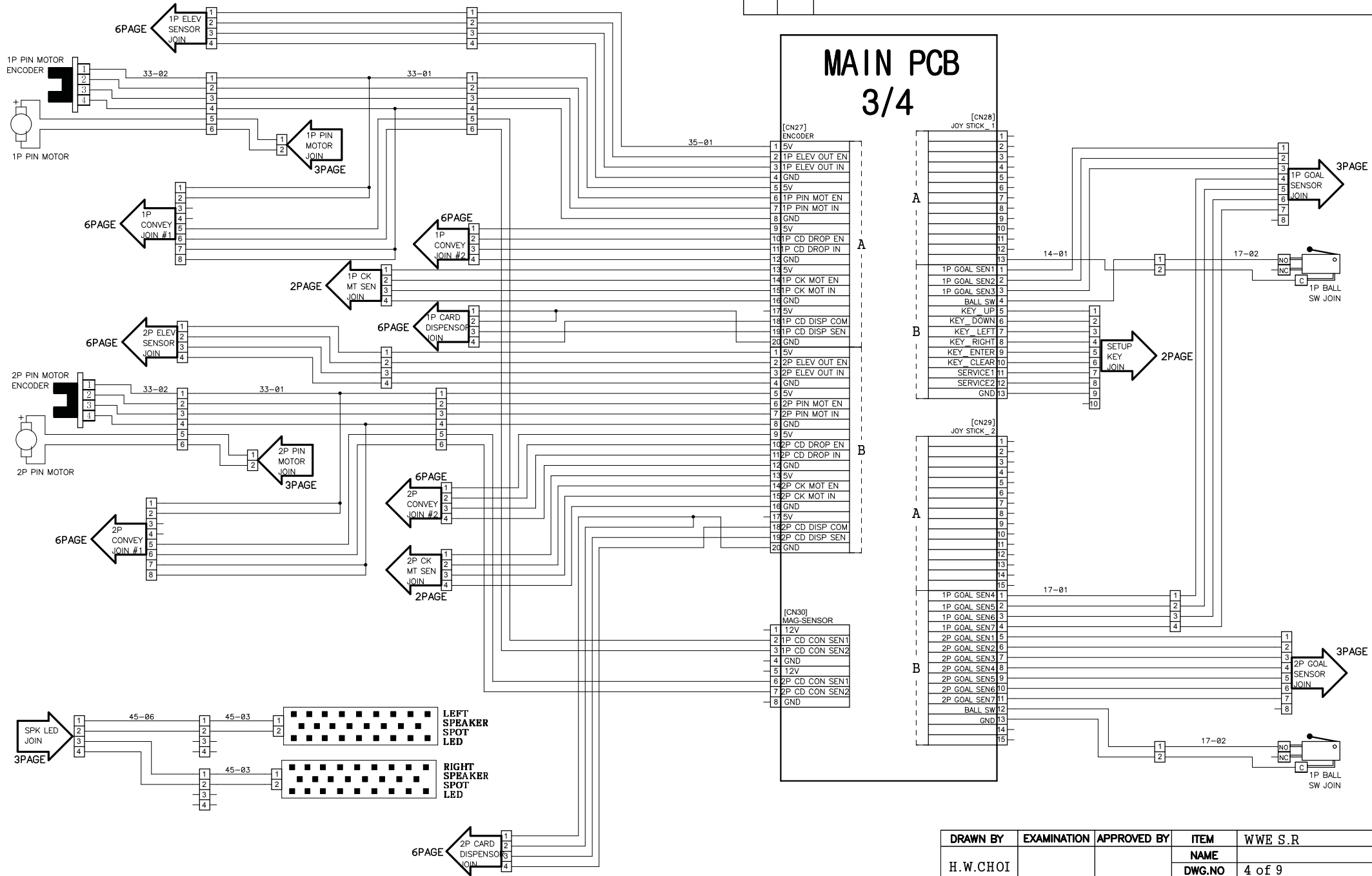

DRAWN BY	EXAMINATION	APPROVED BY	ITEM NAME	WWE S.R
H.W.CHOI			DWG.NO	4 of 9
<b>ANDAMIRO</b>				CODE.NO
				DATE

MARK	DATE	REVISION

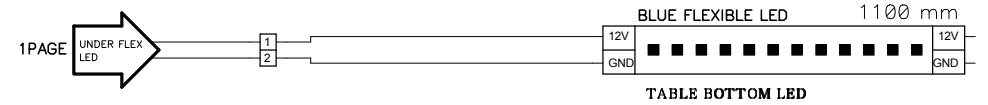
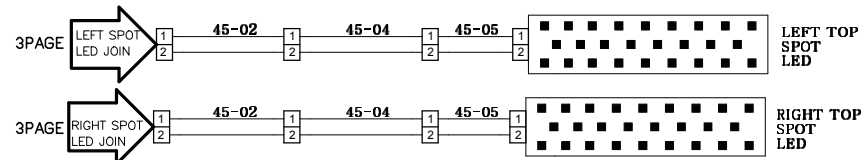
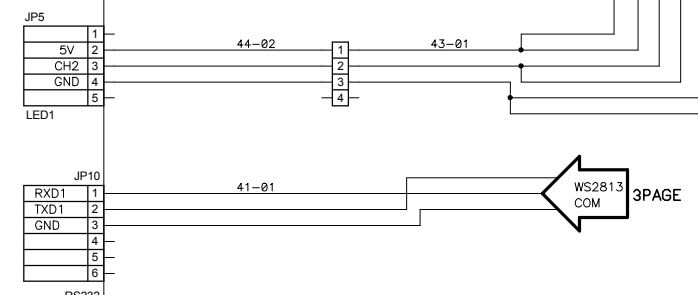
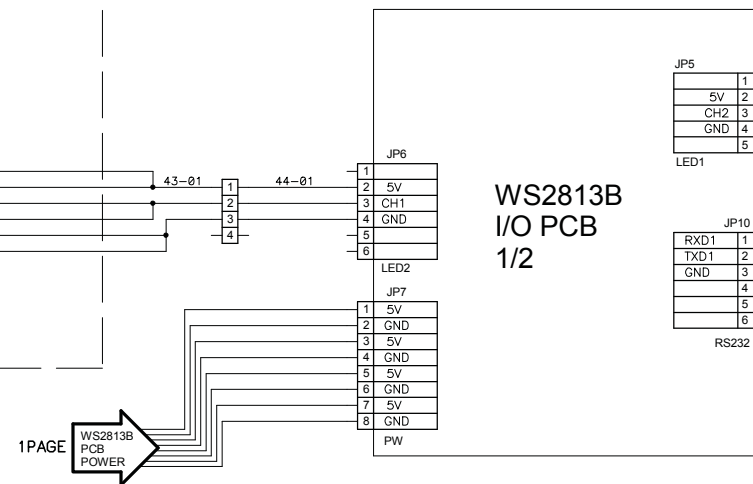
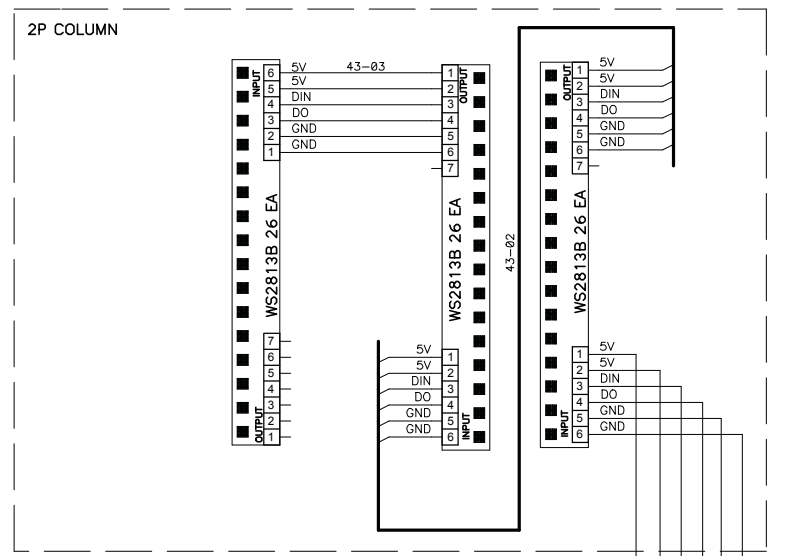
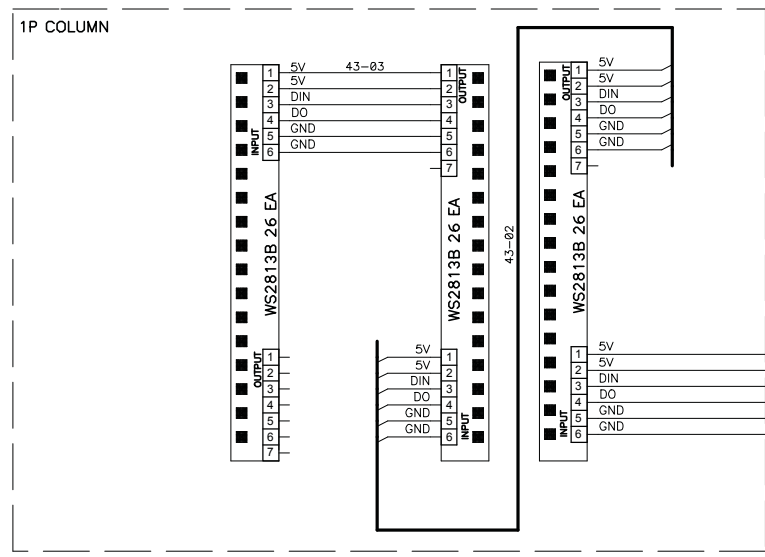
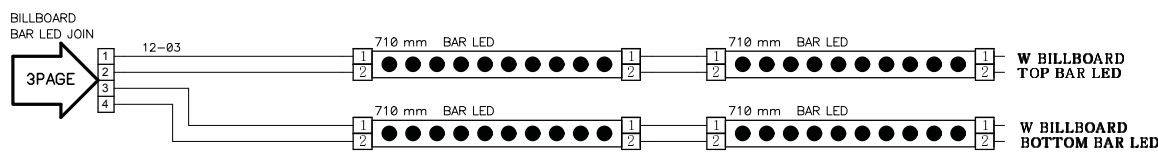
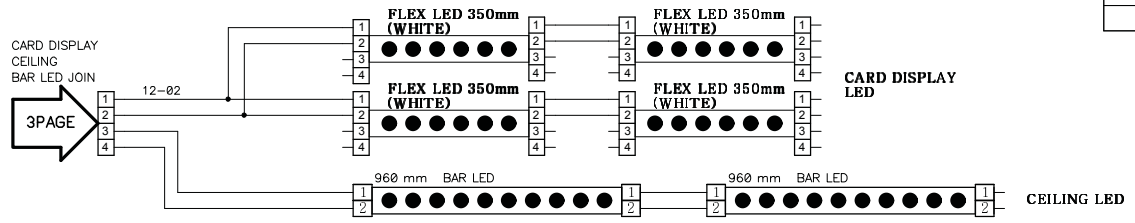

DRAWN BY	EXAMINATION	APPROVED BY	ITEM	WWE S.R
H.W.CHOI			NAME	
			DWG.NO	5 of 9
			CODE.NO	
			DATE	20180807

ANDAMIRO



MARK	DATE	REVISION

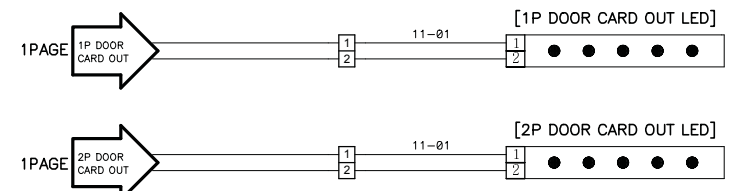
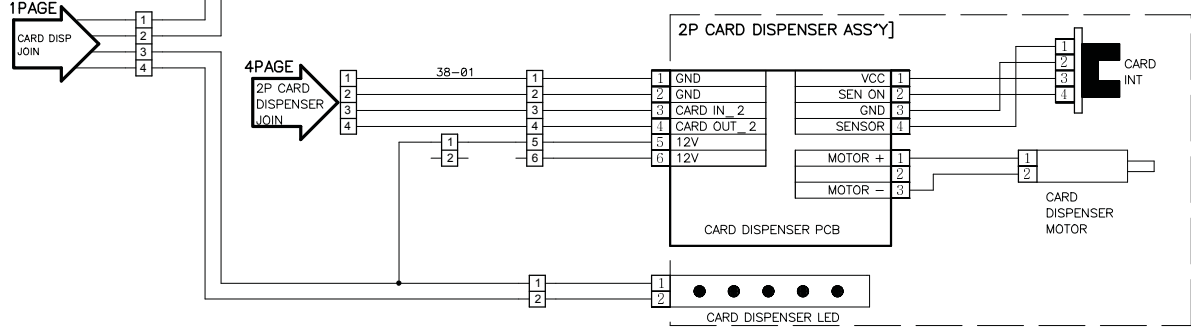
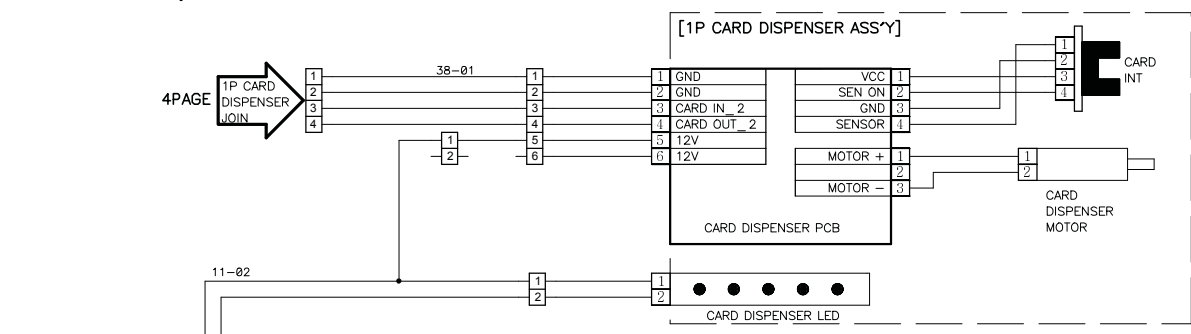
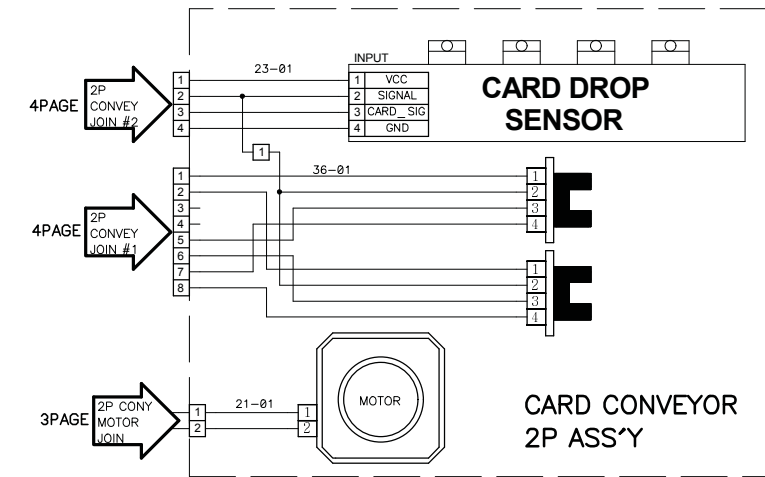
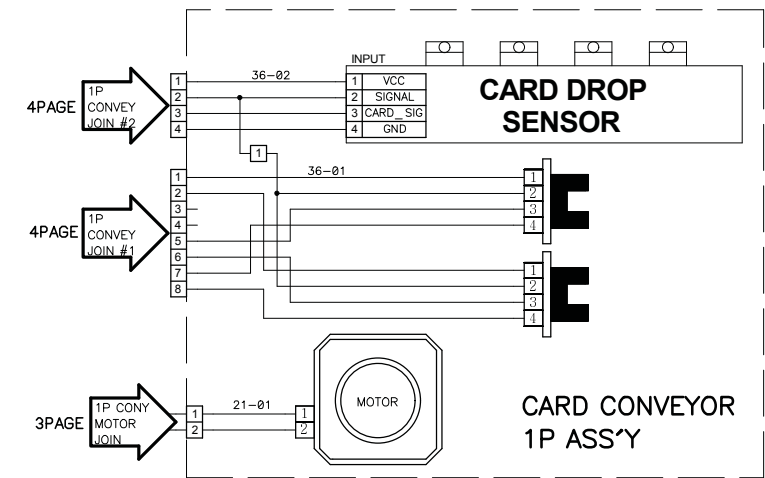
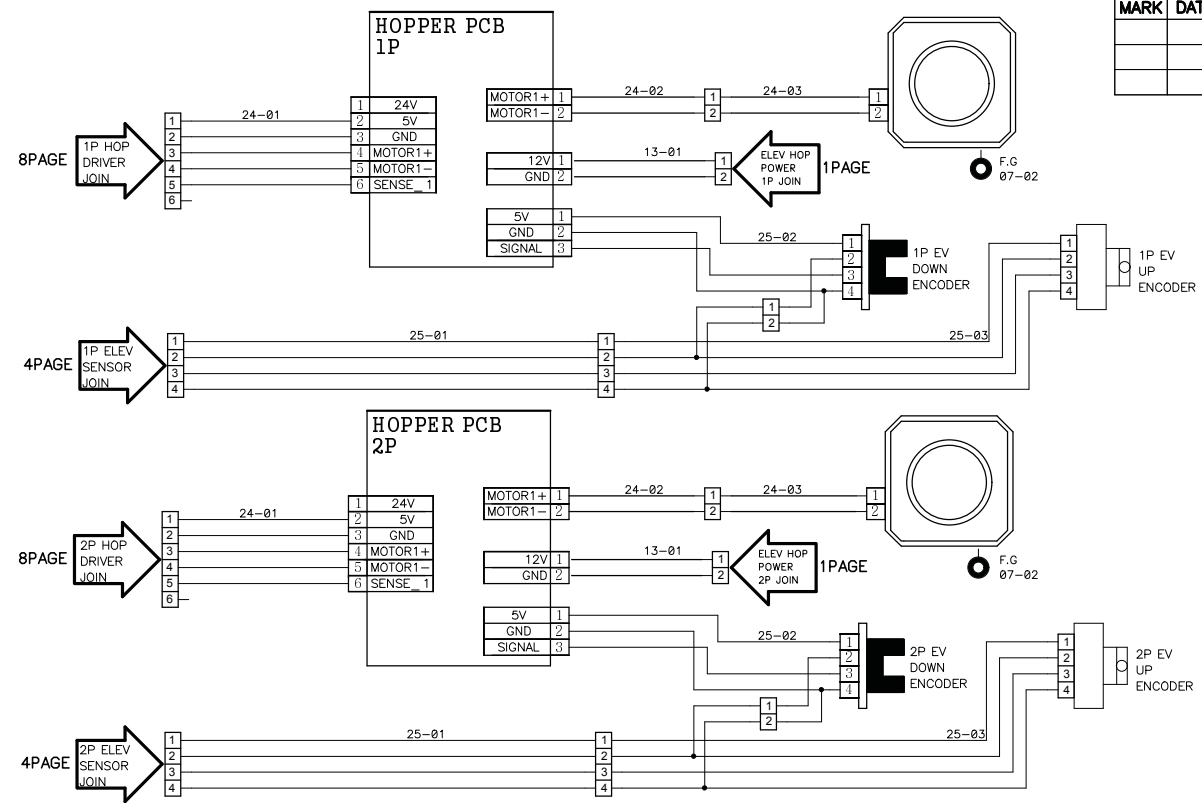

DRAWN BY	EXAMINATION	APPROVED BY	ITEM	WWE S.R
H.W.CHOI			NAME	
			DWG.NO	6 of 9
			CODE.NO	
			DATE	20180807

ANDAMIRO



MARK	DATE	REVISION

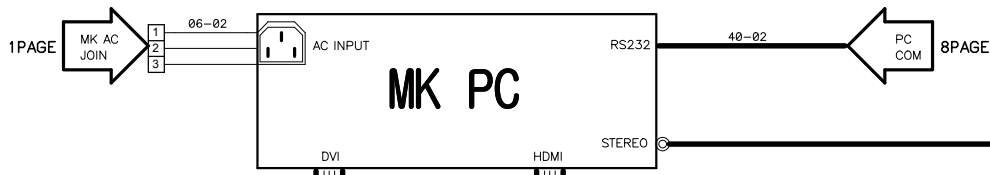
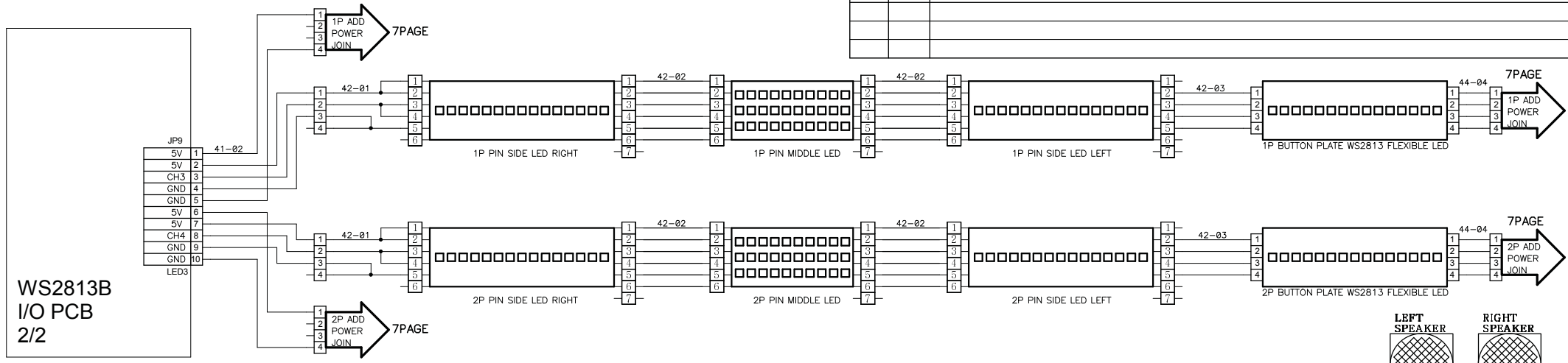

1P 23" LCD

2P 23" LCD

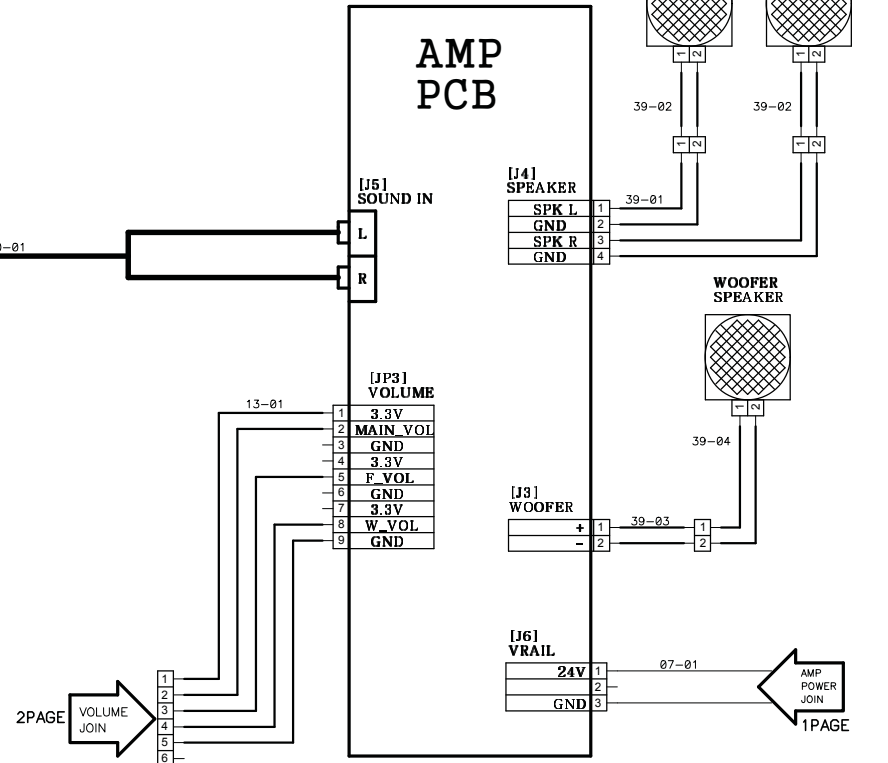
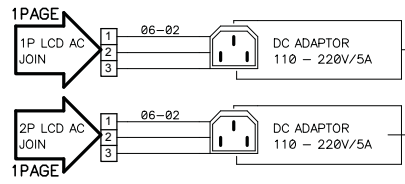

DRAWN BY	EXAMINATION	APPROVED BY	ITEM	WWE S.R
H.W.CHOI			NAME	
			DWG.NO	7 of 9
			CODE.NO	
			DATE	20180807

ANDAMIRO

MARK	DATE	REVISION

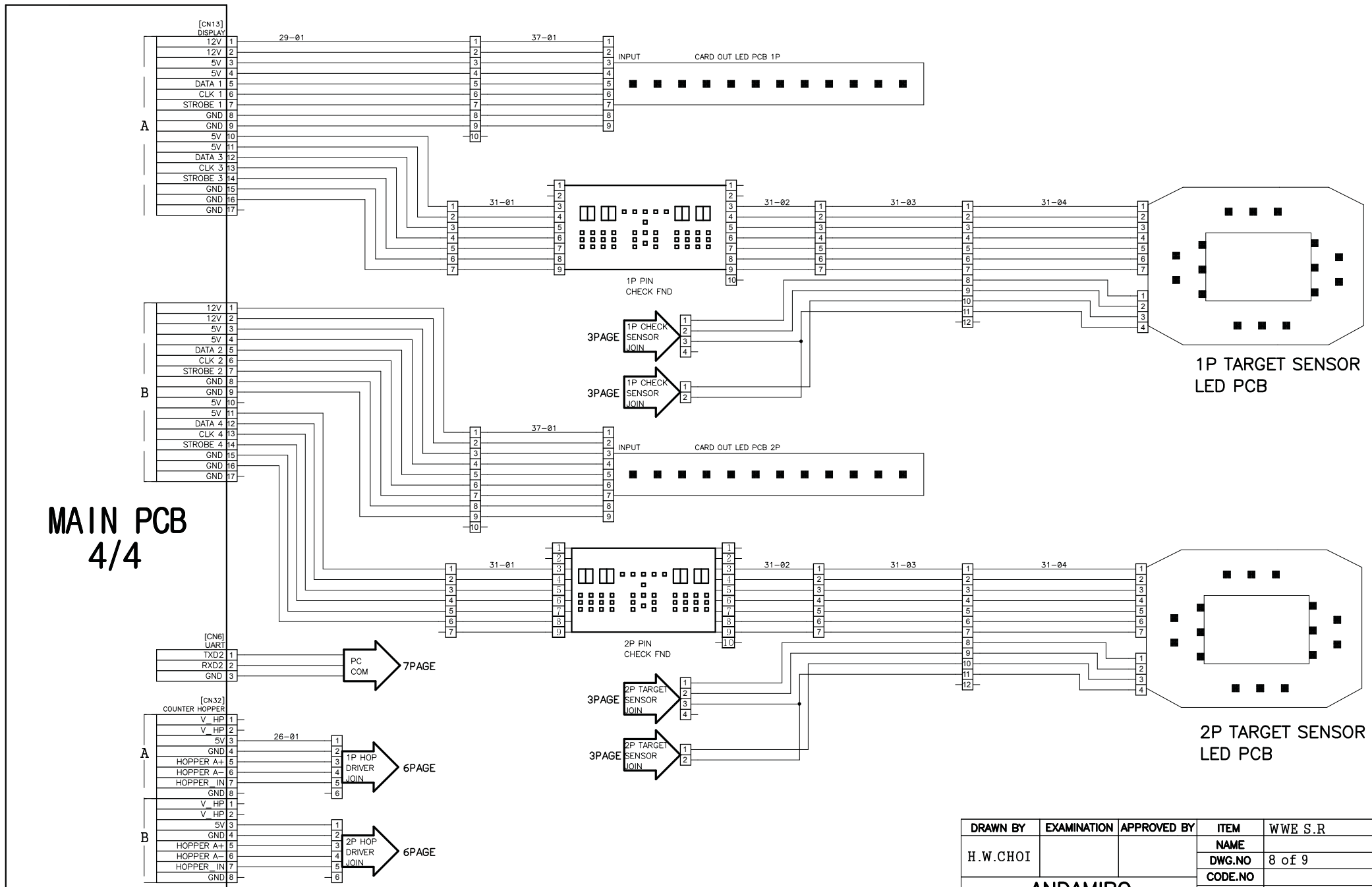

DRAWN BY	EXAMINATION	APPROVED BY	ITEM	WWE S.R
H.W.CHOI			NAME	
<b>ANDAMIRO</b>			DWG.NO	8 of 9
			CODE.NO	
			DATE	20180807

# GENERAL COIN OPTION

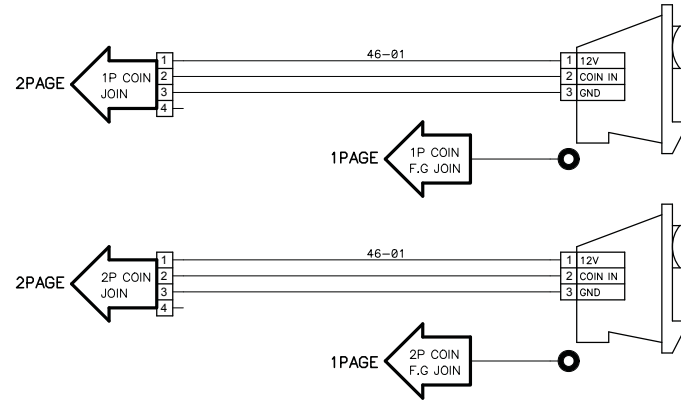

MARK	DATE	REVISION

# CEC COIN OPTION

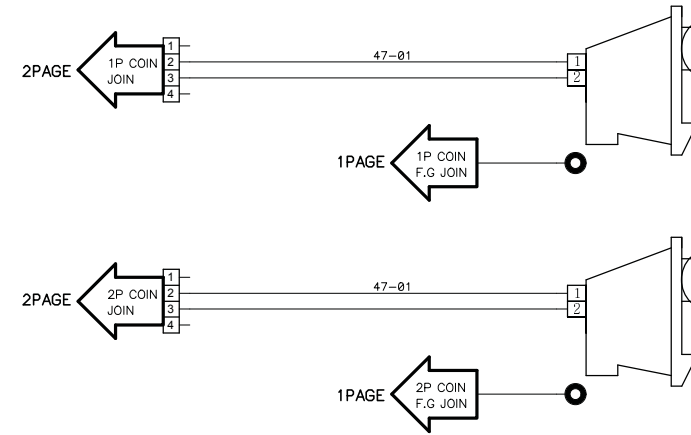

# NAMCO COIN OPTION

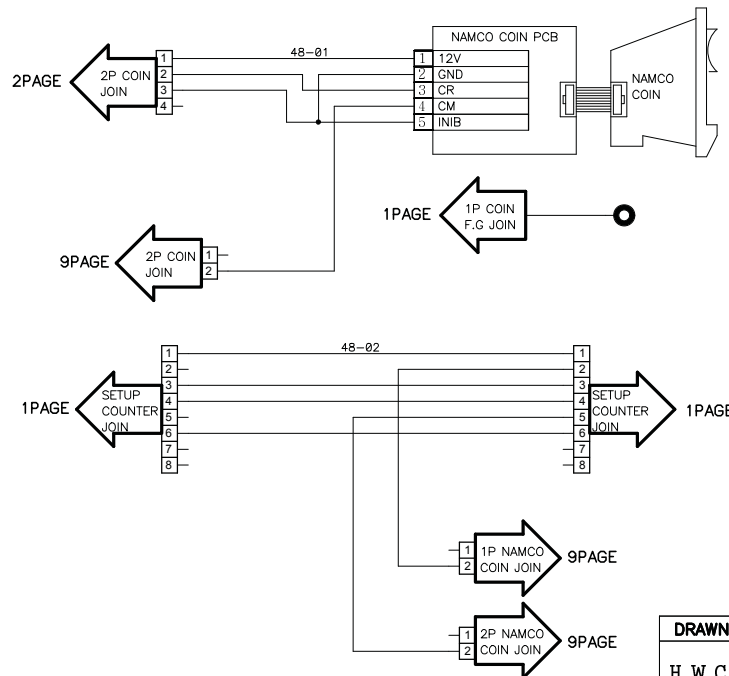
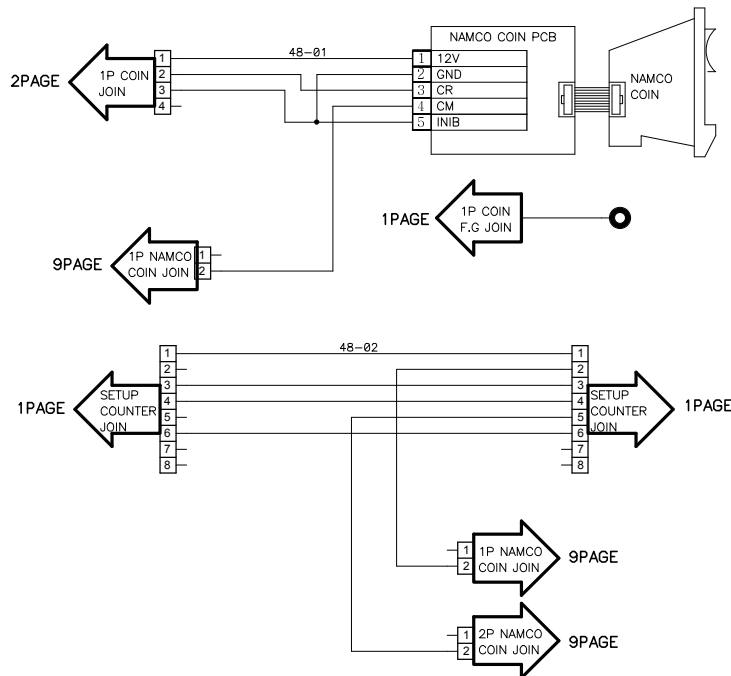

DRAWN BY	EXAMINATION	APPROVED BY	ITEM	WWE S.R
H.W.CHOI			NAME	
			DWG.NO	9 of 9
			CODE.NO	
			DATE	20180807

**ANDAMIRO**



## **ANDAMIRO WARRANTY POLICY**



Andamiro warrants to the original purchaser that all of its products will be free from defects in material and workmanship.

**Andamiro warrants the parts from date of shipment as follows.**

- **One Year Limited Warranty : Electronic Boards**
- **6 Months Limited Warranty : Moving Parts**

For any key components within the warranty period, Andamiro will repair or replace defective components free of charge.

When placing a warranty request, the customer is requested to furnish the following information:

1. Name of the game.
2. Serial Number of the game.
3. A Detailed Description of the defect/s experienced.

This warranty does not apply to the defects caused due to misuse or abuse of the product.

Any alterations made to game or game parts will void this warranty.

For warranty details on our product range please visit our website, [www.andamiro.com](http://www.andamiro.com).

ANDAMIRO CO., LTD.  
[www.andamiro.com](http://www.andamiro.com)



Please complete the following request form to place a warranty request and send it to ANDAMIRO Korea either by fax (Fax No: +82-31-908-7548) or by e-mail. The e-mail address of the person in charge of each region is shown in our web-site, [www.andamiro.com](http://www.andamiro.com)

For the on-line request, please visit our web-site, [www.andamiro.com](http://www.andamiro.com) and click "Customer Service" and then click "Contact Us" in which you shall find the e-mail address of the person in charge of each region.

**1. Company Name :** \_\_\_\_\_

**2. Mailing Address :** \_\_\_\_\_

\_\_\_\_\_

**3. E-Mail Address :** \_\_\_\_\_

**4. Phone No :** \_\_\_\_\_

**5. Name of the person in charge :** \_\_\_\_\_

**6. Description of the product defects**

6-1 ) Name of the Game : \_\_\_\_\_

6-2 ) Serial No : \_\_\_\_\_

6-3 ) Date of Purchase : \_\_\_\_\_

6-4 ) Detailed description of the product defects.

\_\_\_\_\_

\_\_\_\_\_

\_\_\_\_\_

Remarks: If possible, please provide us with related photos and videos which will be greatly appreciated to verify the cause of the problem.



---

**ANDAMIRO CO., LTD.**

TEL : 82-31-909-2123~5

**[ADDRESS OFFICE]** 704-1 Techno Town, 138, Ilsan-ro, Ilsandong-gu, Goyang-si,  
Gyeonggi-do, Republic of Korea 10442

**[FACTORY]** 72 Nochemgil, Ilsan-donggu Goyang-si, Gyonggi-do, 410-834 korea

**USA BRANCH**

ANDAMIRO USA CORP.

TEL : 1-310-767-5800

**[ADDRESS]** 17230 S. Main Street Gardena, California 90248 U.S.A.

Homepage <http://www.andamiro.com/>